

ARTES 460|560

Automatic Relay Test Systems



CONTENTS

ARTES Automatic Relay Test Systems	3
Product overview	4
Technical data ARTES 460 560.....	5
Applications.....	6
System description	7
Current and voltage amplifiers.....	7
Equipment and handling	10
The ARTES testing software	14
ARTES test monitors.....	18
Test monitor overview.....	29
Software modules and packages.....	29
Options and accessories	30
Device options.....	30
Cable sets	30
Adapters.....	31
Wrap-around bags and carrying cases.....	32
Training courses and seminars	33
Specifications ARTES 460 560	34

ARTES

AUTOMATIC RELAY TEST SYSTEMS

The purpose of power system protection is to use accurate and reliable protection devices to detect faults promptly and without fail and to minimize impairments to the power supply by selectively switching off faulted sections of the system.

The use of suitable protection devices can significantly improve the safety and reliability of complex electrical power systems and installations. Regular testing is the only way to ensure that these protection devices function correctly throughout their operational life.

More than 20 years of experience in developing and manufacturing automatic relay test systems have gone into creating the third generation of ARTES test instruments. Back in 1996, KoCoS was the first company to present Windows-based testing software for controlling and operating test equipment and the company continues to play a pioneering role in the design of clearly structured and ergonomic user interfaces today.

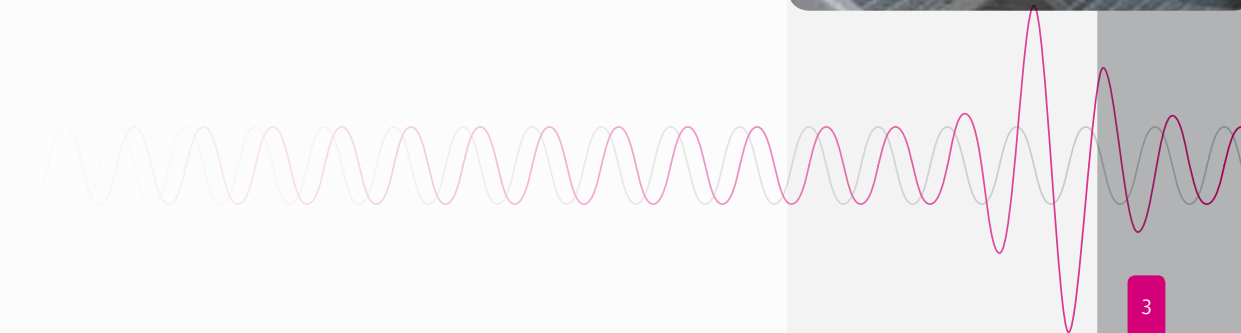

ARTES

PRODUCT OVERVIEW

ARTES 460|560 test systems are practical solutions which can cope with just about any relay testing task.

ARTES 460

Compact test system for three-phase tests, can be used as a universal tool for testing digital protection relays.

Article number 00001302



ARTES 560

Compact test system for three-phase tests with a particularly powerful current amplifier for testing digital and self-powered protection relays.

Article number 00001304



Technical data ARTES 460|560

Sources	Separately and independently configurable	
Frequency range	DC...3 kHz	
Transient signals	DC...4 kHz	
Phase angle	0...360°	
Voltage amplifier	2 switchable output ranges	
300 V output range	4-ph.: 4 x 0...300 V / 75 VA 1-ph.: 1 x 0...600 V / 150 VA	
150 V output range	4-ph.: 4 x 0...150 V / 75 VA 1-ph.: 1 x 0...300 V / 150 VA	
Low-level signal outputs	Separately and independently configurable	
Output range	ARTES 460/3: 7 x 0...10 V _{pk}	ARTES 460 560: 10 x 0...10 V _{pk}
DC output	12...260 V, overload and short-circuit protection	
Output power	50 W (across the entire output range)	
Analog inputs	2 switchable measuring ranges	
Measuring ranges	4 x 0...±10 V / 600 V _{rms} 4 x 0...±20 mA / 0...±10 V	
Binary inputs	Configurable as wet/dry contacts	
Quantity / Groups	8 / 2	
Binary outputs	2 potential-free and galvanically isolated output relays	
AC switching capacity	0...250 V / 8 A	
DC switching capacity	0...300 V / 8 A	
Supply voltage	100...265 VAC / 120...265 VDC	
Rated frequency	47...63 Hz	
Interfaces	USB, Ethernet	
Housing	19" portable	
Dimensions (mm)	470 x 162 x 316 (W x H x D)	

	ARTES 460/3	ARTES 460	ARTES 560
Current amplifier	3 x 0...16 A / 40 VA	6-ph.: 6 x 0...16 A / 40 VA 3-ph.: 3 x 0...32 A / 80 VA	6-ph.: 6 x 0...32 A / 100 VA 3-ph.: 3 x 0...64 A / 200 VA
Weight	10 kg	10 kg	15 kg



Applications

ARTES 460|560 test systems are used to carry out functional tests and tests of configured excitation and tripping characteristics, including any automatic reclosing functions of protection devices such as:

- Distance protection relays
- Differential protection relays
- DT/IDMT relays
- Voltage relays, frequency relays

They can also be used to test and calibrate power, voltage, current and frequency converters.

With four voltage and six current outputs, these test systems make light work of even highly complex tests on static, digital and self-powered protection relays, without additional equipment. Test quantities are calculated and tests controlled fully automatically.

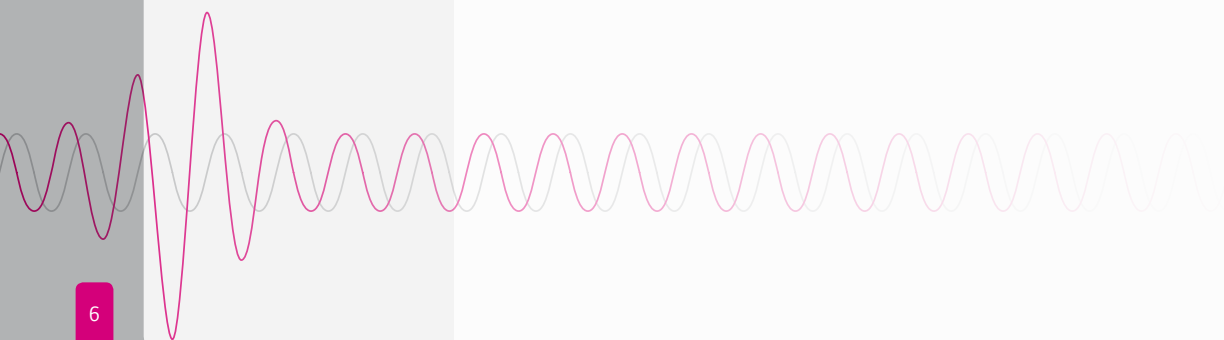

SYSTEM DESCRIPTION

The ARTES 460|560 test instruments have been specially developed for harsh transport and operational conditions. The use of state-of-the-art technologies coupled with a high level of system integration has made it possible to accommodate this compact, lightweight test instrument in a portable 19" housing.

Because of the very effective cooling system and automatic fan control, the test instruments go largely unnoticed during operation.

Current and voltage amplifiers

ARTES 460|560 test systems have four voltage outputs and six current outputs. Many tasks in protection relay testing do not require more than three current outputs. The ARTES 460/3 system, which is equipped with three instead of six current outputs, is available as a cost-effective alternative for this situation. The test quantities are monitored constantly by means of an internal feedback measurement of the output signals.

Test currents of up to 3 x 64 A with parallel operation

In order to provide higher test currents, the current amplifiers of the ARTES 560 can be operated in parallel. Because there are 6 current outputs, up to 3 x 64 A can be provided for 3-phase applications.

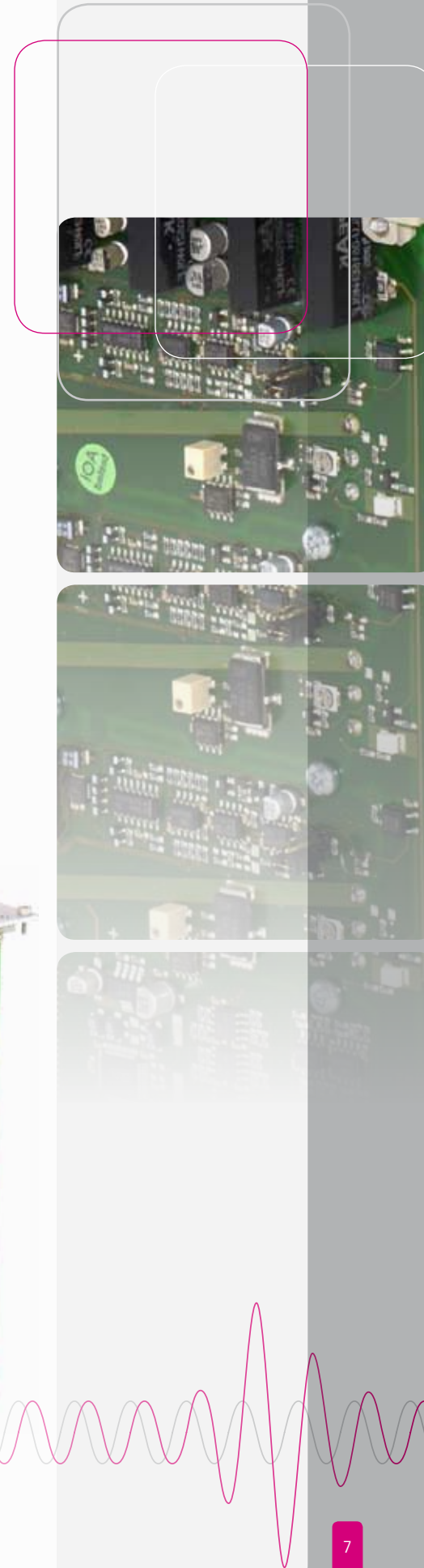

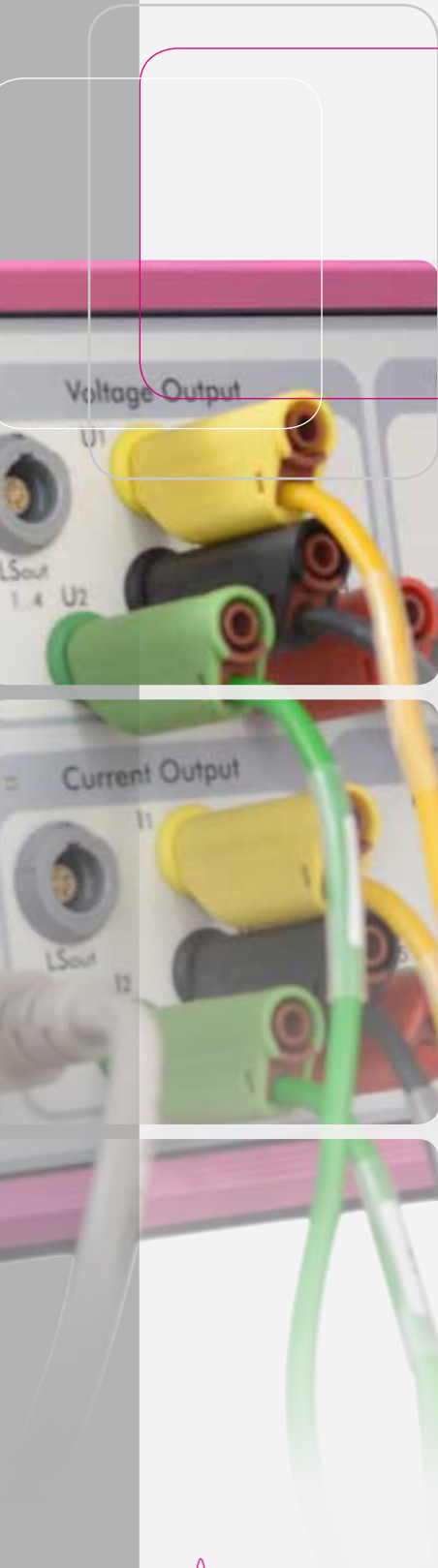

High output power with low test currents

A supply voltage of up to 30 V is available for the ARTES 560 current amplifiers. Even with low test currents, the current amplifiers can provide a high compliance voltage and thus a high level of output power.

Constant output signals for changing burdens

Even if the burden of the device under test changes during output, constant output signals with very high accuracy are guaranteed.

Synthetic signal generation with a powerful signal processor, internal feedback measurements of the output signals in real time and ultra-fast regulation of the amplifiers make this possible and ensure that the signals correspond exactly to the desired values during output.

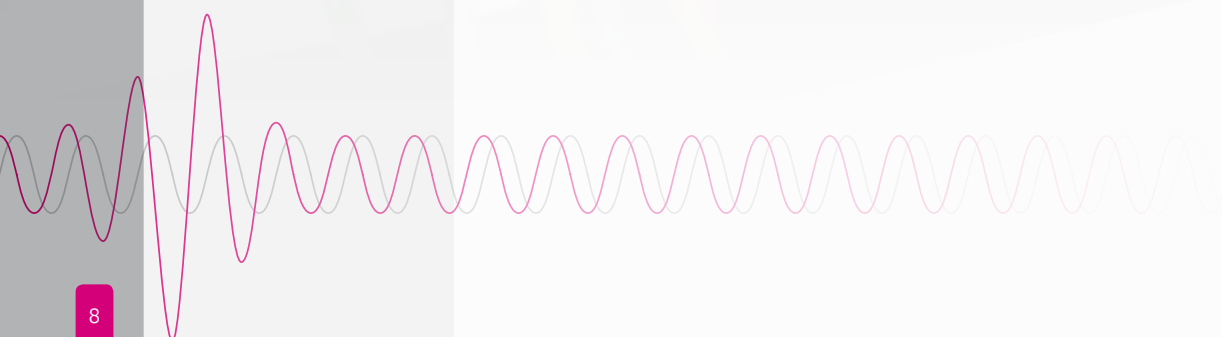

Wide frequency range for the output of transient signals

The fully electronic amplifiers of ARTES 460|560 do not feature transformers in the outputs, so it is possible to generate output signals with a wide frequency range of several kHz. In addition to self-generated signals, records from fault recorder systems can also be output as transient signals.

Immunity to disturbances in the power supply

Powerful, wide-range switching mode power supplies safeguard the power supply to the ARTES amplifiers and ensure fault-free operation and constant output signals. Changes to the output quantities are completely eliminated, including inaccuracies and errors resulting from fluctuations in the supply voltage.

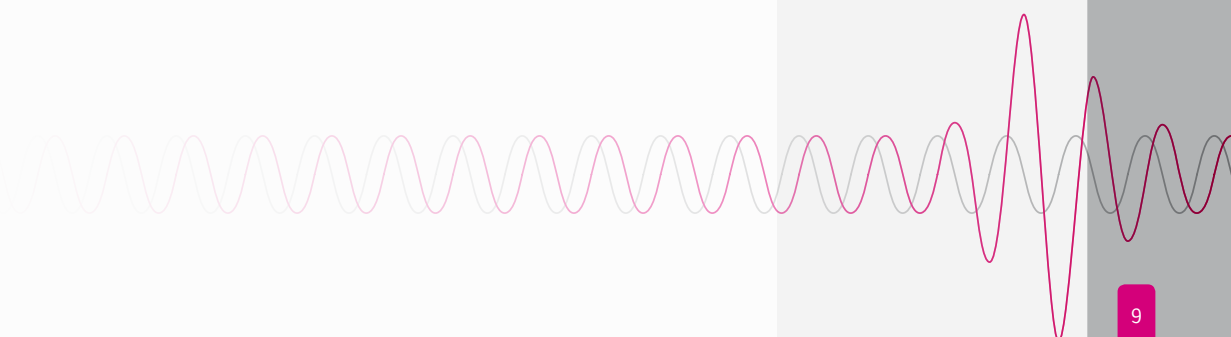
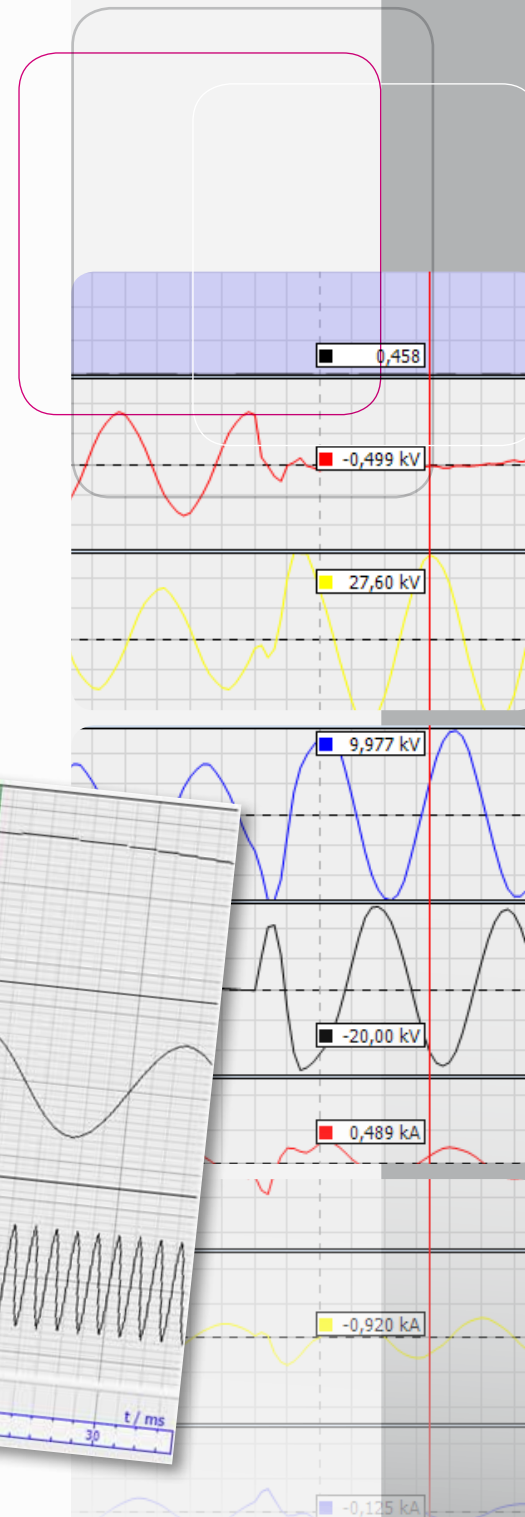
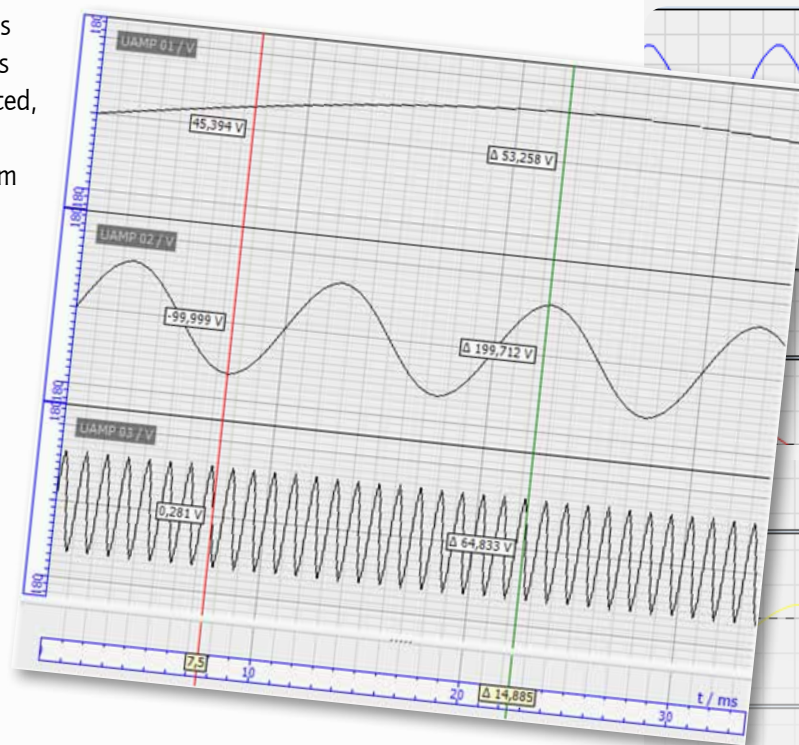

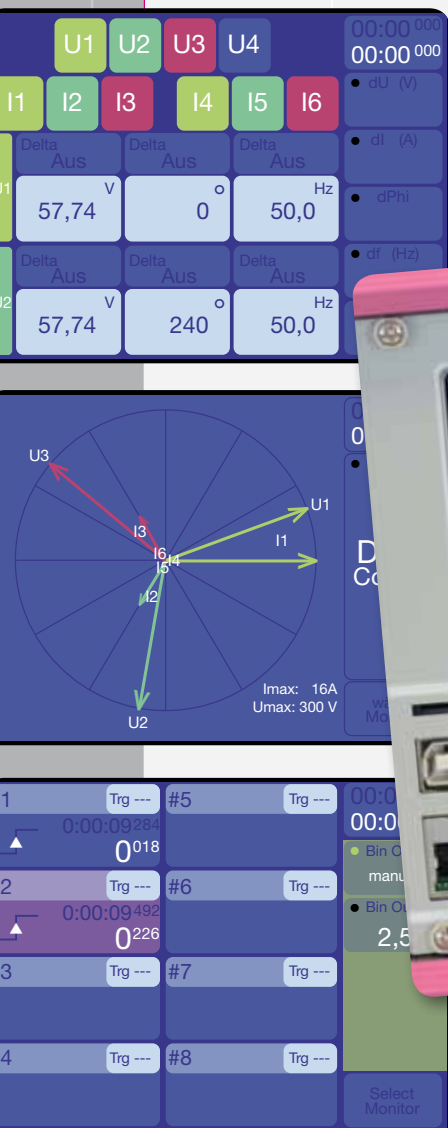

Equipment and handling

ARTES 460|560 test systems are the compact and universal solution for testing all types of protection relays. The built-in control panel, light weight and low noise level make this robust test system equally suitable for use on site and in the lab.

Stand-alone operation with 3.5" touch screen

ARTES 460|560 test instruments can be operated and controlled with the aid of a PC and the ARTES testing software or with the built-in control panel. The control panel features a high-resolution, resistive 3.5" touch screen, two function keys and a jog wheel.

The clearly structured user interface guides the user quickly and intuitively to complete the task in hand. The test instrument reacts directly to user actions, all processes run smoothly and without delay.

Settings can be made quickly with the ergonomic jog wheel.

The illuminated ring integrated in the wheel clearly displays the system status;

acoustic signals are an additional source of information and provide feedback when settings are made and when tests are carried out.

A USB and an Ethernet interface allow direct connection to PCs or any network.

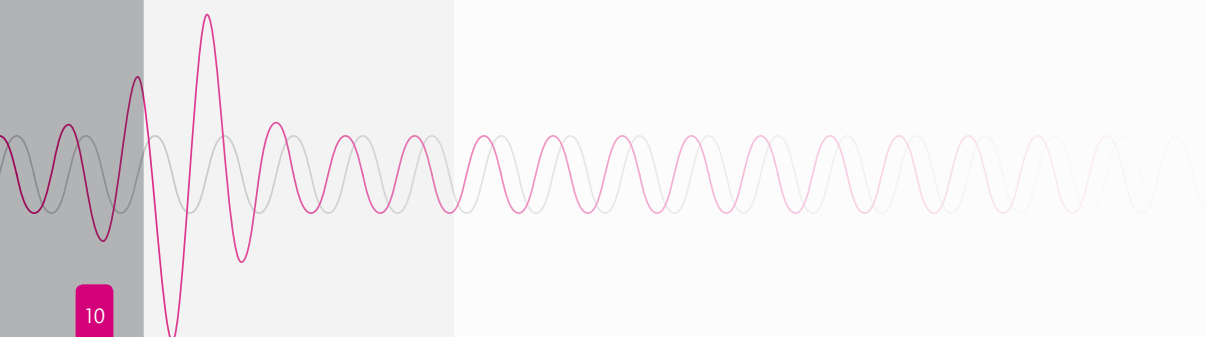

LEDs for status indication

The states and operating modes of the inputs and outputs are indicated by LEDs on the front panel. The user can tell at a glance which outputs are active and can easily identify the states of the binary inputs and outputs.

Analog and binary measurement inputs

ARTES 460|560 test systems have eight binary inputs which are protected against polarity reversal and are configurable for measuring dry or wet contacts.

In addition to the binary measurement inputs, the test systems also feature eight analog inputs with a switchable measuring range.

Output of control commands via binary outputs

ARTES 460|560 test systems can address the protection device under test with binary signals as well as with analog measurement quantities. These binary signals are generated simultaneously with the analog quantities and can be used as control commands for the protection device during the test procedure.

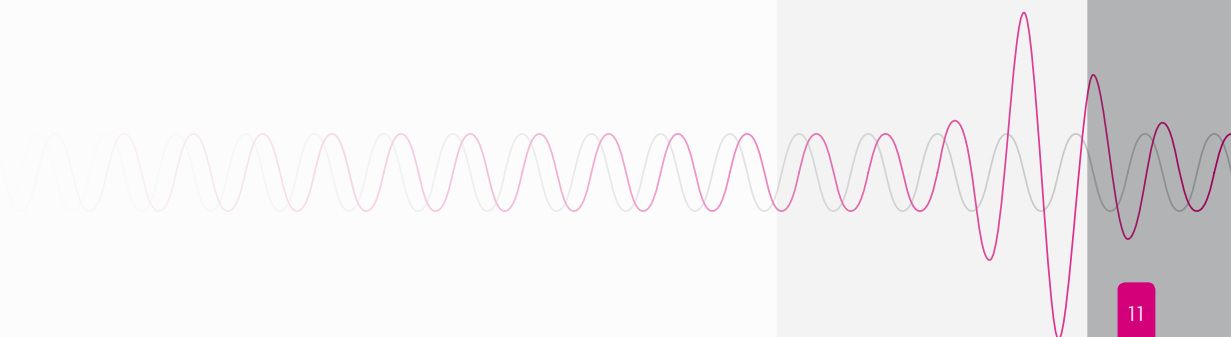

DC Aux.

+

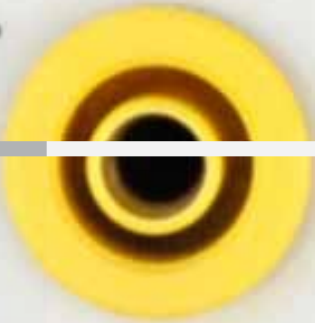

-

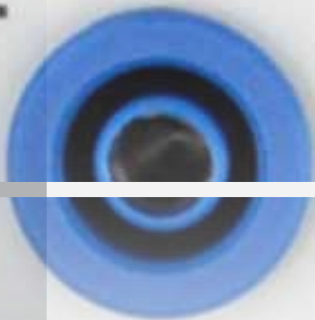

Testing protection devices with low-level signal inputs

Special low-level outputs with very high accuracy make it possible to test protection devices with low-level signal inputs as well. The behaviour of various different sensors, such as Rogowski coils, is reproduced precisely.

Separate auxiliary power supply

ARTES 460|560 test systems have a separate auxiliary power supply as standard equipment. The auxiliary voltage can be used to supply the test object, for example. The range is from 12 to 260 VDC.

Operation in a vertical position

All the connections required for linking up to the device under test can be found on the front panel where they are arranged ergonomically and are easily accessible. The power supply and the external interfaces are also located on the front panel. ARTES 460|560 test systems can be stood upright on the floor if necessary and still be operated comfortably.



Can be used all over the world

The voltage and frequency range of the integrated wide-range power supply units provide a high degree of flexibility for powering ARTES 460|560 test instruments, allowing them to be connected to any national supply voltage or to DC station batteries.

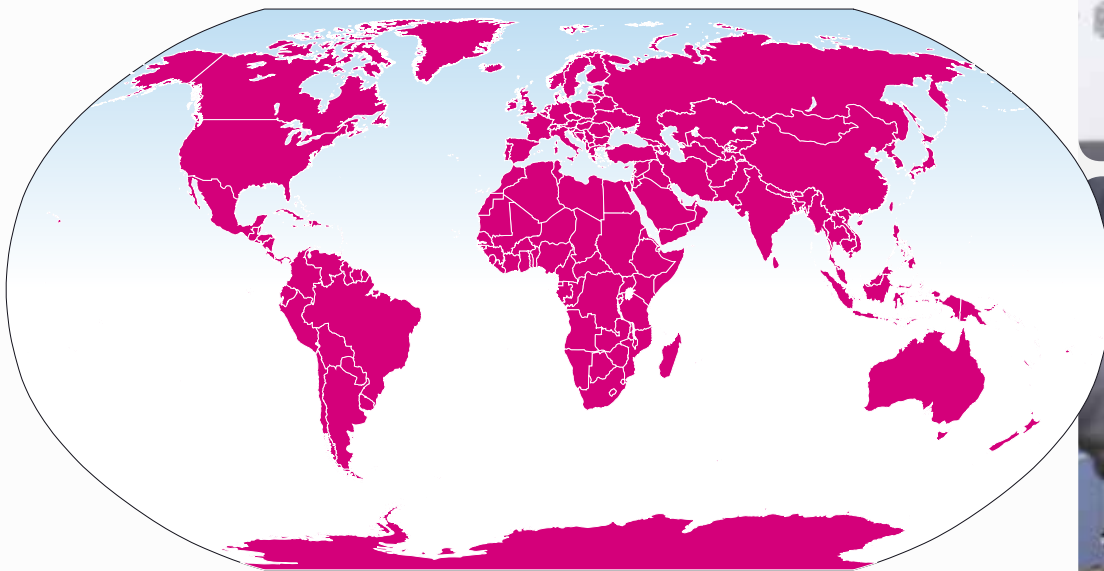

ARTES

Software-controlled device calibration

The ARTES 460|560 test instruments have been specially designed to enable users to carry out the calibration themselves. This eliminates periods of unavailability while the test instrument is sent away and also does not involve any costs. Calibration is controlled by the software. There is no need to open the test instrument and make adjustments using potentiometers.

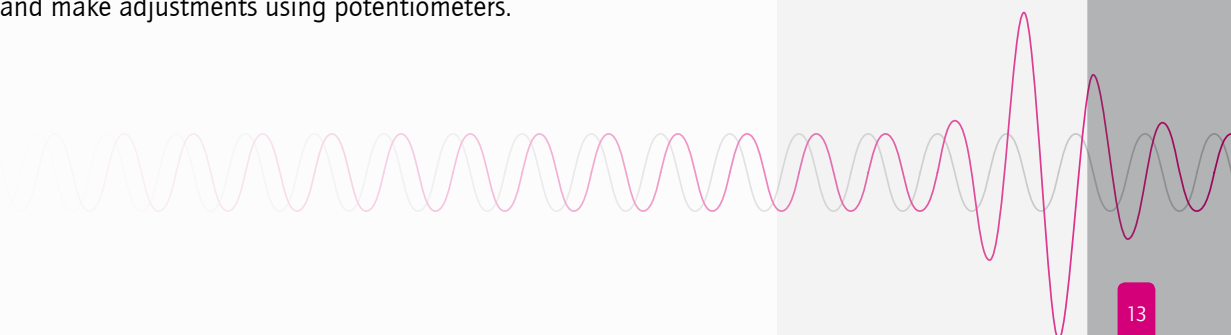

THE ARTES TESTING SOFTWARE

Featuring a Microsoft Fluent user interface and an impressive range of functions, the new **ARTES** relay testing software from KoCoS breaks new ground, securing the company's position at the cutting edge of the development of Windows-based testing software.

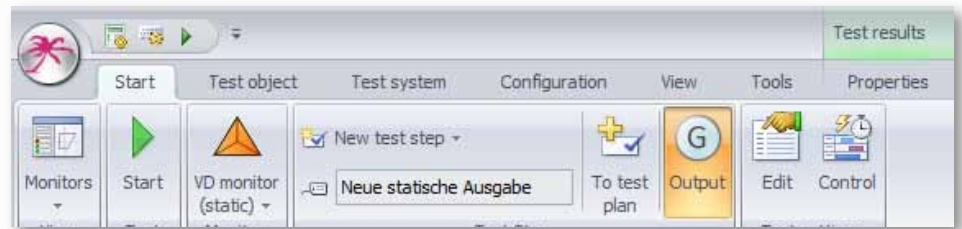

The restructured Microsoft Fluent user interface provides a wide range of new functions.

The Fluent interface makes working with the ARTES testing software both faster and more efficient. Traditional menus and toolbars have been replaced by a ribbon. The advantages of this user interface include improved handling and significant savings in time due to the use of context-specific tabs and the ease with which new users become familiar with the software.

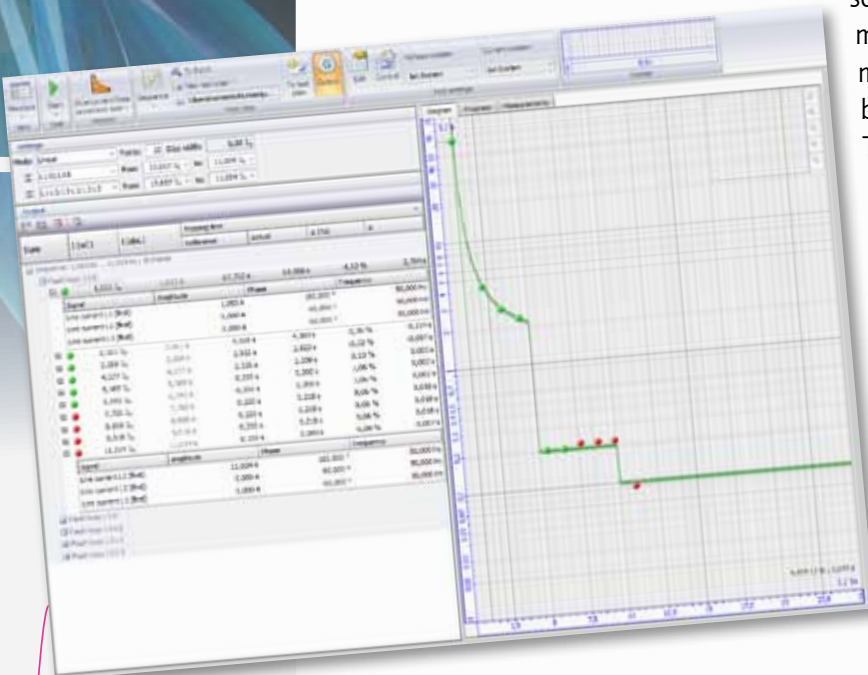

Clearly structured asset management based on the test object

Another noteworthy feature of the software is the asset management. The global definition of protection functions as well as the derivation and inheritance of properties from a wide variety of different type templates are what make this feature so special. In addition, it is possible to edit specific individual relay settings and test instructions as well as to make global settings for instrument transformers, earthing and the direction of the rotating field.

The asset management also allows the integration and management of external documents. This means that any information which may be required is available all the time.

Graphical display of connection schemes

A graphical display of connection schemes can also be found in the ARTES testing software. This makes it easier to connect the device under test and goes a long way towards ruling out mistakes.

Pre-defined models are available for the various protection functions and can be selected directly, making configuration much simpler.

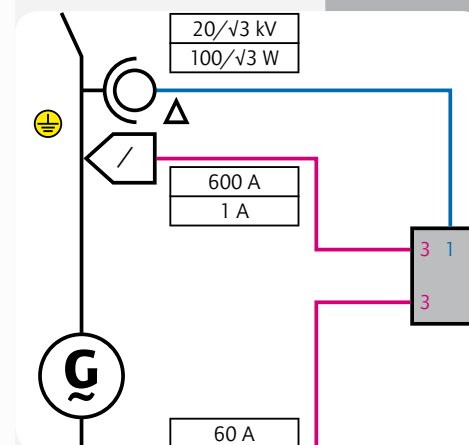
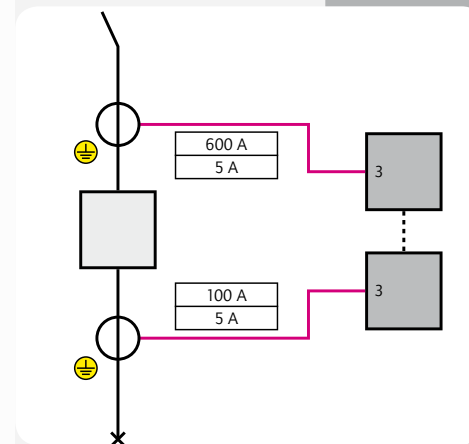
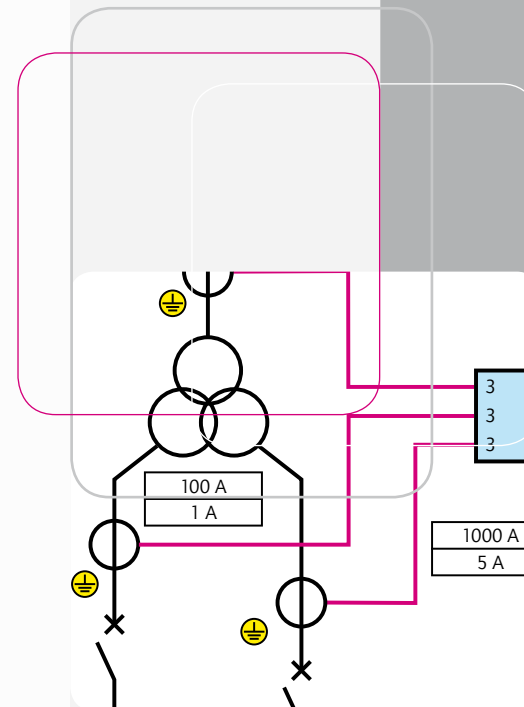
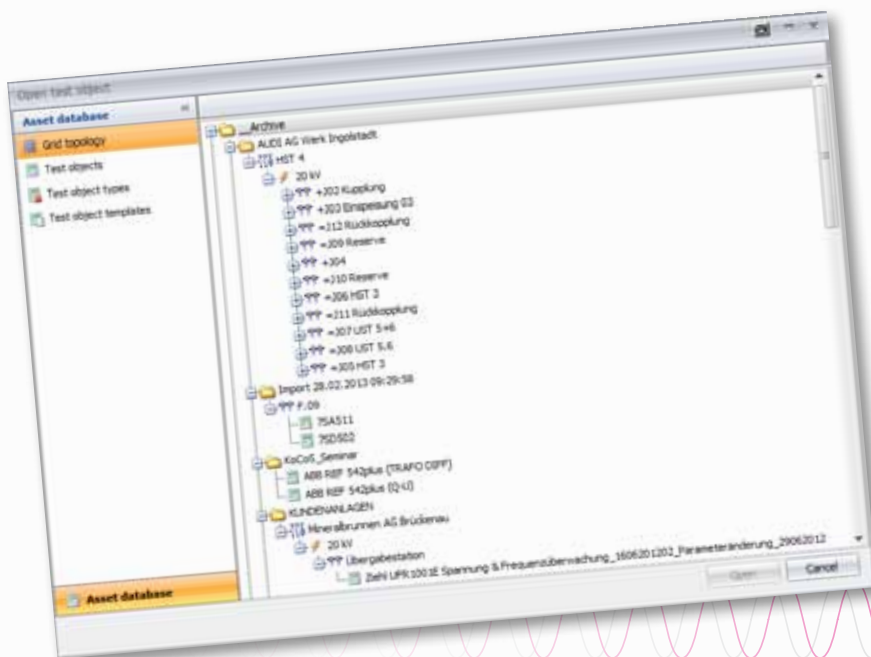

Individual test plans

An individual test plan can be created easily for each device under test. Individual tests can be combined to form complete device or type tests which can then be repeated any number of times under identical test conditions, making it easy to automate entire test procedures.

Display and evaluation of measurement results

The progress of the analog input quantities and the status signals and commands of the device under test captured by ARTES are displayed time correctly in real time during tests. This information is displayed both graphically and numerically, making it possible to observe and evaluate the test procedure right away.

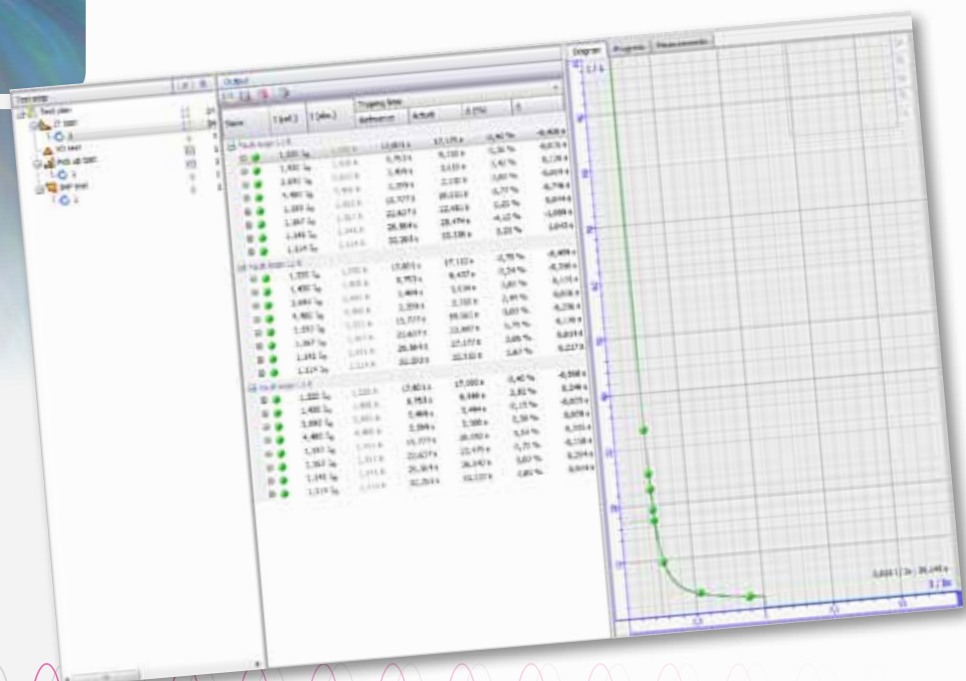

The reaction of the device under test is evaluated automatically by the programme during the course of a test. For each test point, an online indicator shows whether or not the result lies within the configured tolerance range.

Immediately after the test, all the results are displayed clearly in a table. Each line contains the information on an individual test point.

The list of results can also be presented in the form of a test report. This report is generated automatically by the programme and contains all the relevant data, parameters and test results. The structure and the layout of test reports can be tailored in accordance with individual requirements and preferences.

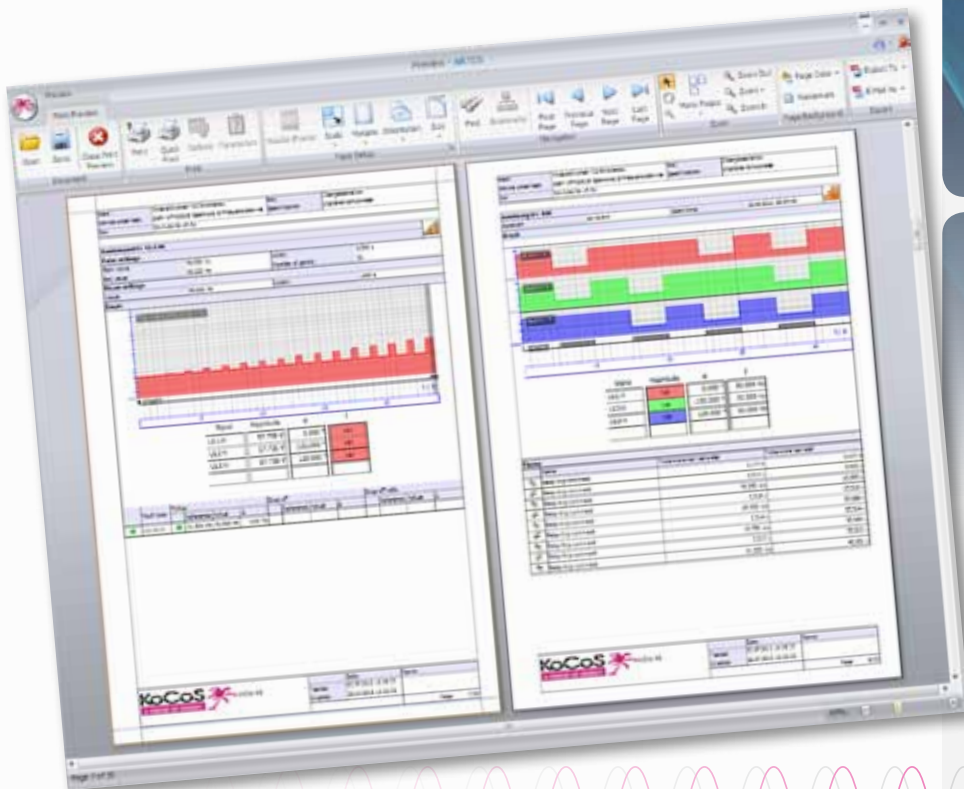

ARTES test monitors

Generally speaking, the VD-Monitor is capable of meeting all test requirements.

The ARTES software also offers a wide range of convenient test monitors which have been specially developed for testing specific protection functions. These test monitors simplify, automate and significantly speed up tests for a range of different types of relays.

VD-Monitor

The VD-Monitor enables the user to test any protection function by setting the test quantities manually. As well as entering secondary values, primary values can also be used to define all the settings, so it is no longer necessary to go to the trouble of converting the quantities manually.

The output signals of the current and voltage amplifiers are set entirely independently from one another as regards amplitude,

phase and frequency and are varied independently from one another during tests. In addition, the output signals of certain or all amplifier outputs can also be ramp ascending or descending within the configured range.

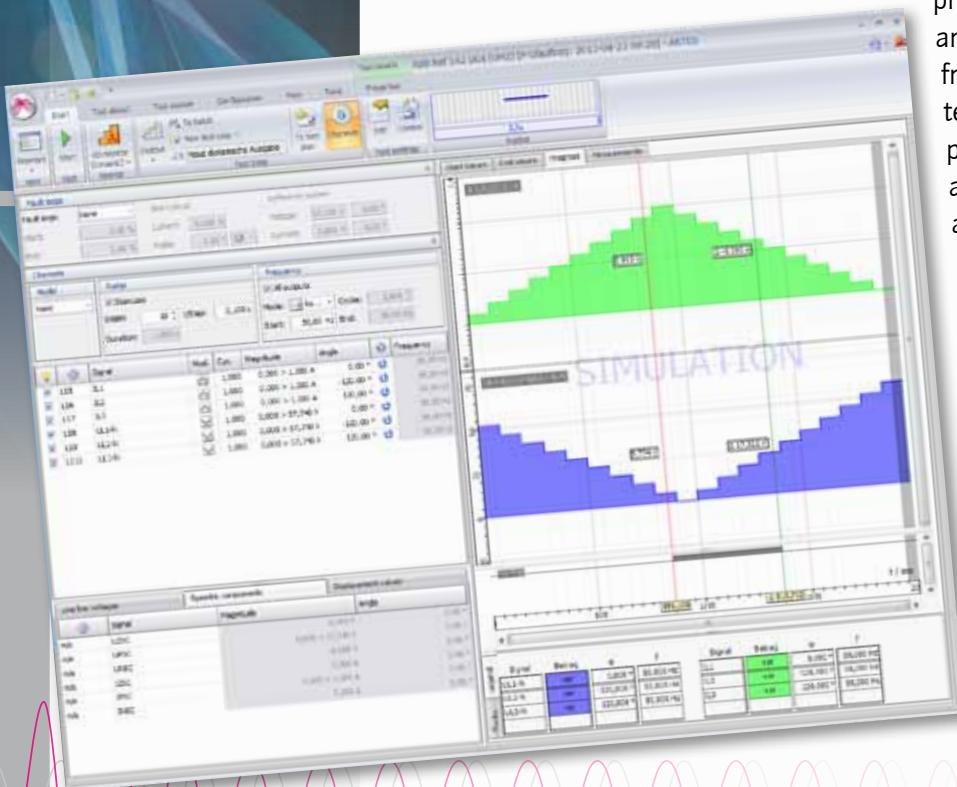

Presetting fault loops

Selecting a fault loop facilitates the reproduction of a specific fault. The parameters which can be modified for the selected fault are automatically pre-defined, making it possible to test a two-pole fault taking into account the phase-correct behaviour of the faulted quantities, for example.

Fault definition with symmetrical components

It is also possible to define the test quantities by entering the symmetrical components directly. The output quantities are calculated automatically by the software. Unsymmetrical systems, caused by earth faults, for example, can be defined directly with speed and efficiency.

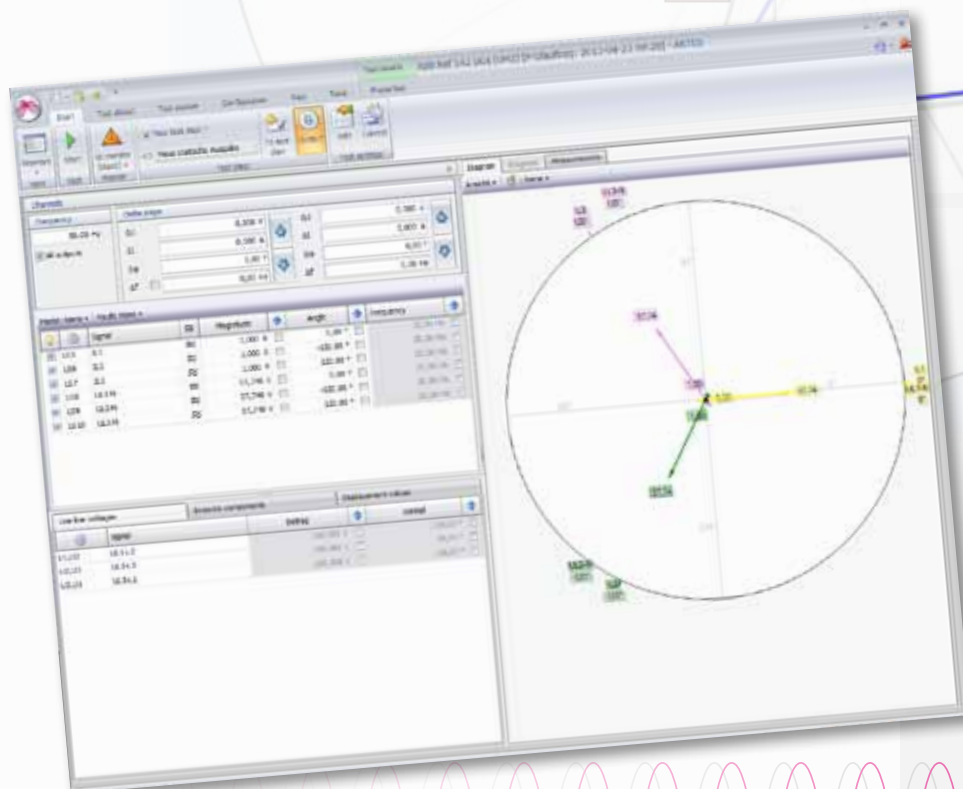

IMP-Monitor

Article number 00001254

The IMP-Monitor can be used to check the operating times and impedance zones of distance protection devices.

The programme automatically calculates the test quantities for the defined fault impedances and the selected fault type. The required fault impedance is defined in the complex impedance plane or in the distance-time diagram.

In addition, the IMP-Monitor enables the ARC (Auto-Reclose) function of the protective equipment to be checked. The aim of this test is to verify the dead times of a successful or unsuccessful auto-reclose operation.

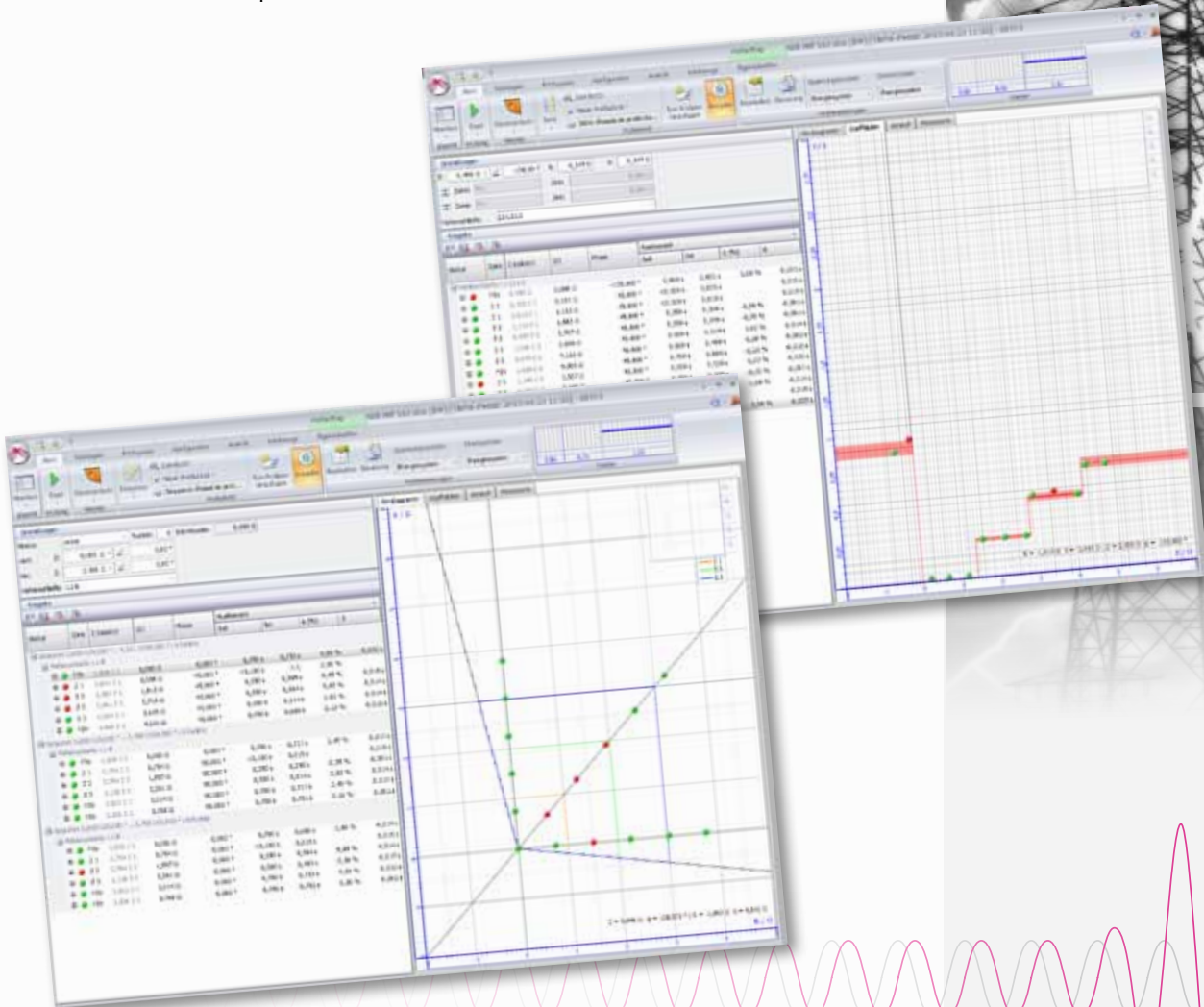

TRANSIG-Monitor

Article number 00001255

The TRANSIG-Monitor can be used to check the correct functioning of the device under test in real conditions.

The monitor can be used for the full graphical display and output of recorded signal characteristics which are available in standard COMTRADE format and can come from fault recording systems or digital protection relays. During tests these signal characteristics are played back by the test instrument as transient signal waveforms.

The TRANSIG-Monitor also includes a signal editor which can be used to configure and calculate any signal characteristic. The signal characteristics can be generated from a basic function, such as a sine wave, with one or more superimposed functions, such as a direct component, exponential functions, harmonics, etc.



SYNC-Monitor

Article number 00001256

The SYNC-Monitor can be used to test paralleling devices and synchronizers which use frequency and voltage adjusters.

During a test, the systems to be synchronised are represented by the voltages of the test instrument. The amplitude and the frequency of the test quantities can be changed manually or via the control commands of the synchronizer. During a test, the test quantities and the voltage, frequency and phase difference between the voltage to be synchronised and the reference voltage are displayed numerically in real time in the SYNC-Monitor display. The phase difference is also displayed graphically in the synchroscope.

The evaluation of measurement values is performed automatically immediately after a test. A table displays the test quantities at test begin, at the time the switching command is issued and at the time the circuit breaker closes, taking into account the operating (closing) time of the circuit breaker.

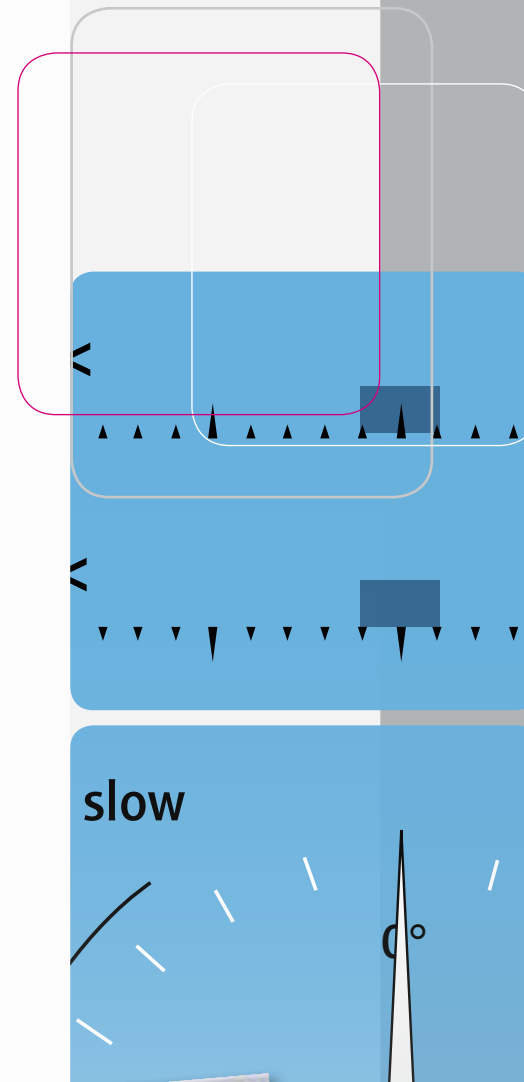



DIFF-Monitor

Article number 00001257

The DIFF-Monitor enables the tripping characteristic and operating times of differential protection relays to be checked.

Test values are calculated automatically with reference to the nominal data of the transformer and the HV/LV data. With transformers using phase-rotation vector groups, for example YD 5, the programme performs a phase adjustment between the currents of the high voltage and low voltage side which are to be compared. In addition to the vector group adjustment, an amplitude adjustment is also performed.

Test evaluation is performed with reference to the stabilization characteristic of the differential protection device.

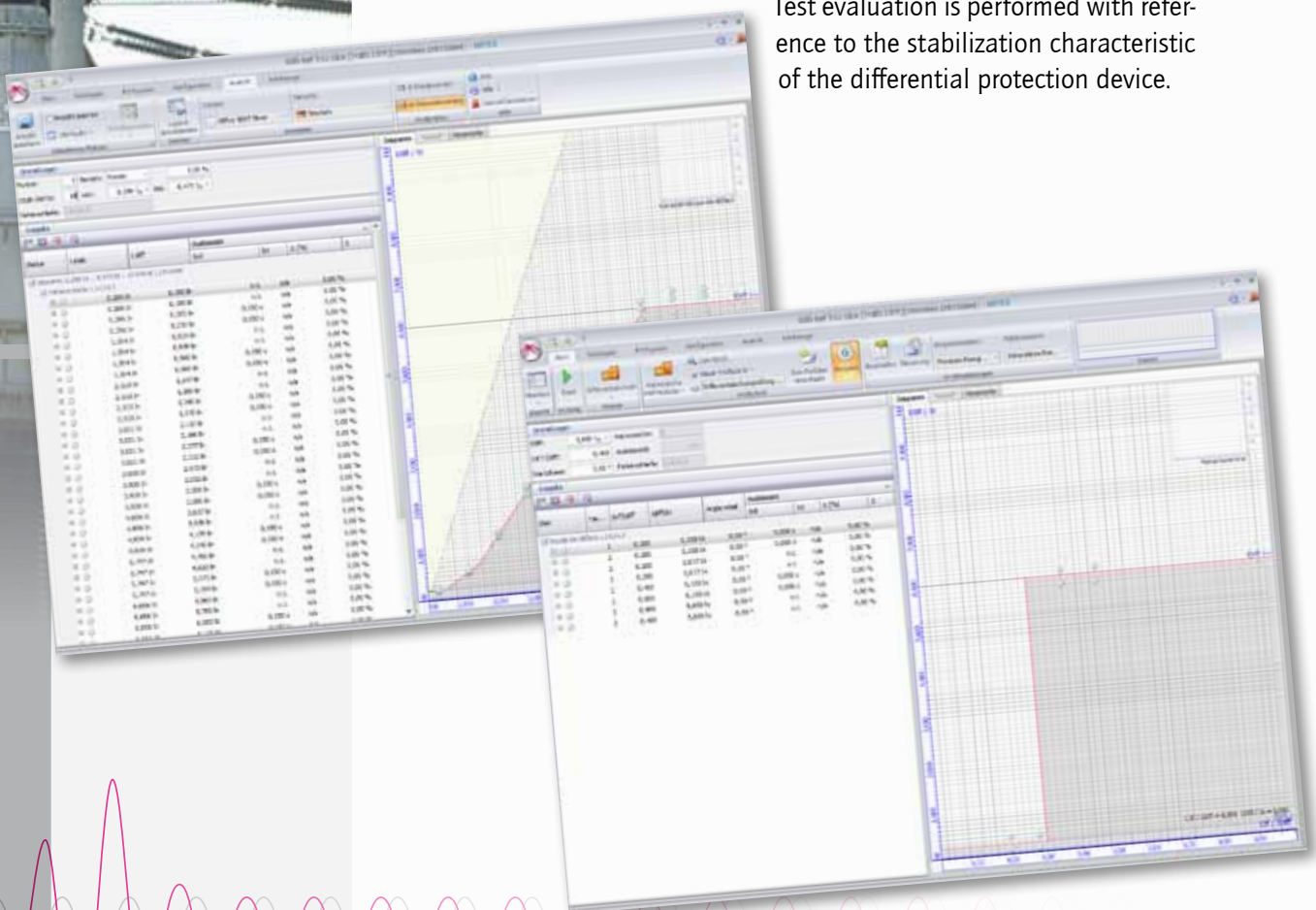

TD-Monitor

Article number 00001258

The TD-Monitor provides an easy way to test transducers. In addition to current, voltage, frequency and phase transducers, it is also possible to test active power, reactive power and apparent power transducers and devices used for measuring the power factor or reactive power factor.

The output quantity of the transducer is recorded during the test via the analog inputs of the ARTES device.

In the TD-Monitor, the test quantities and the output signal of the transducer are displayed numerically in real time during tests. In addition, the absolute error, the relative error and the full scale error are calculated and displayed both numerically and graphically.

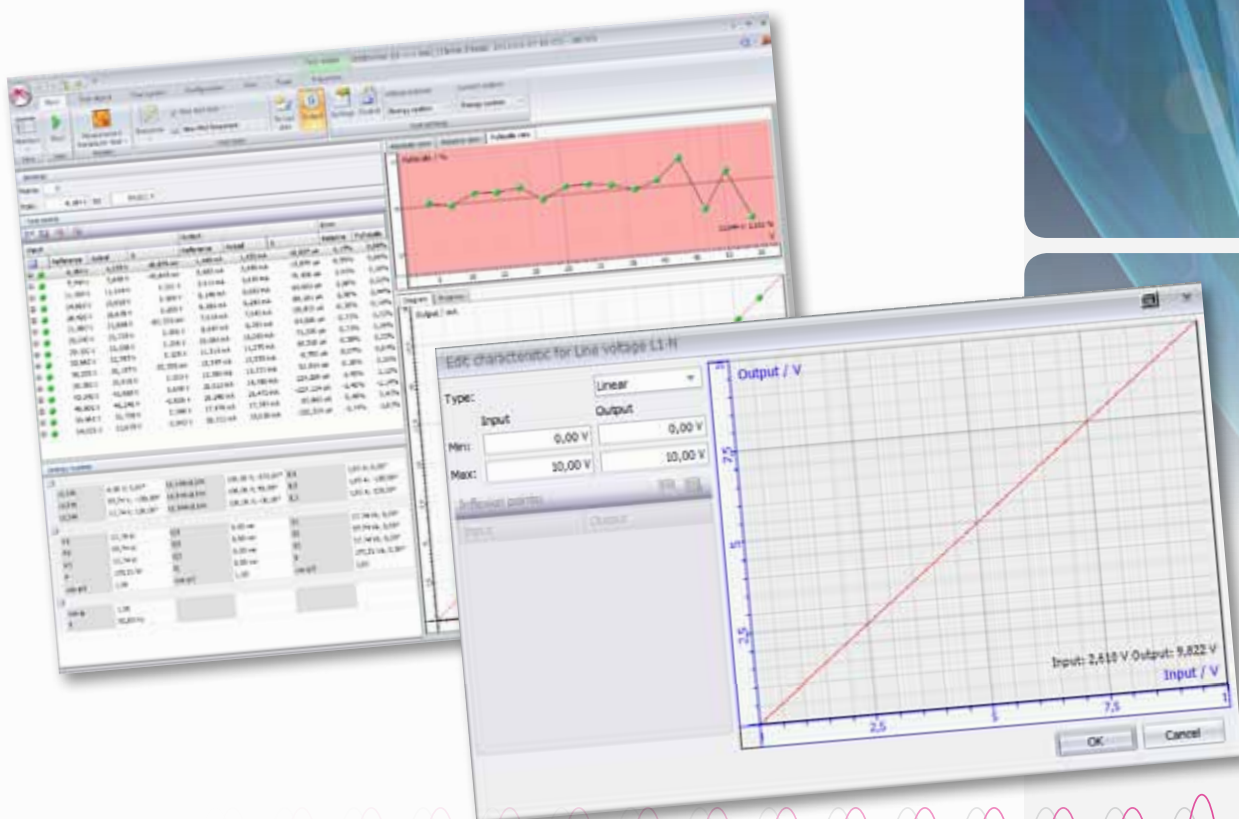

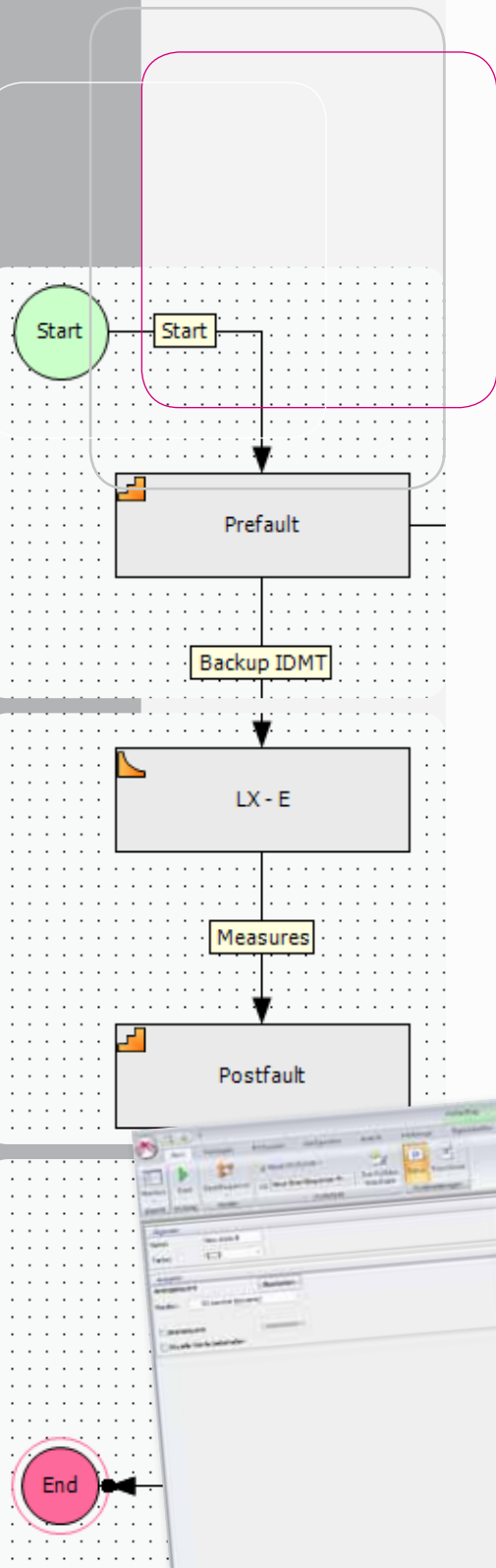

SmartSequencer

Article number 00001259

The SmartSequencer can be used to create any kind of test procedure. A test procedure is similar to a test sequence in the VD-Monitor, which can consist of a number of static and dynamic signal characteristics.

However, in the VD-Monitor the individual characteristics (also termed states) have a fixed, pre-defined length and are run sequentially one after the other.

Using the SmartSequencer it is possible to "run" these states in an event-controlled manner. A different progression condition (transition) can be defined for each state. This might be the reaction of the device under test in the form of a binary signal or alternatively a defined time, for example.



PIC-Monitor

Article number 00001260

The PIC-Monitor can be used to determine the pick-up and drop-off values of protection relays.

This could also be the pick-up value of the second instantaneous tripping set (high set) of an overcurrent relay, for example. The test quantities are issued as stair-step pulsed ramps for this purpose. The amplitudes are increased until the pick-up value is reached. To ascertain the drop-off value, ARTES then automatically switches to a stair-step descending ramp.

The programme calculates the test quantities fully automatically with reference to the start and end values set for the ramps and the fault loop which has been selected. The reaction of the device under test is recorded in real time during the test and subsequently evaluated.

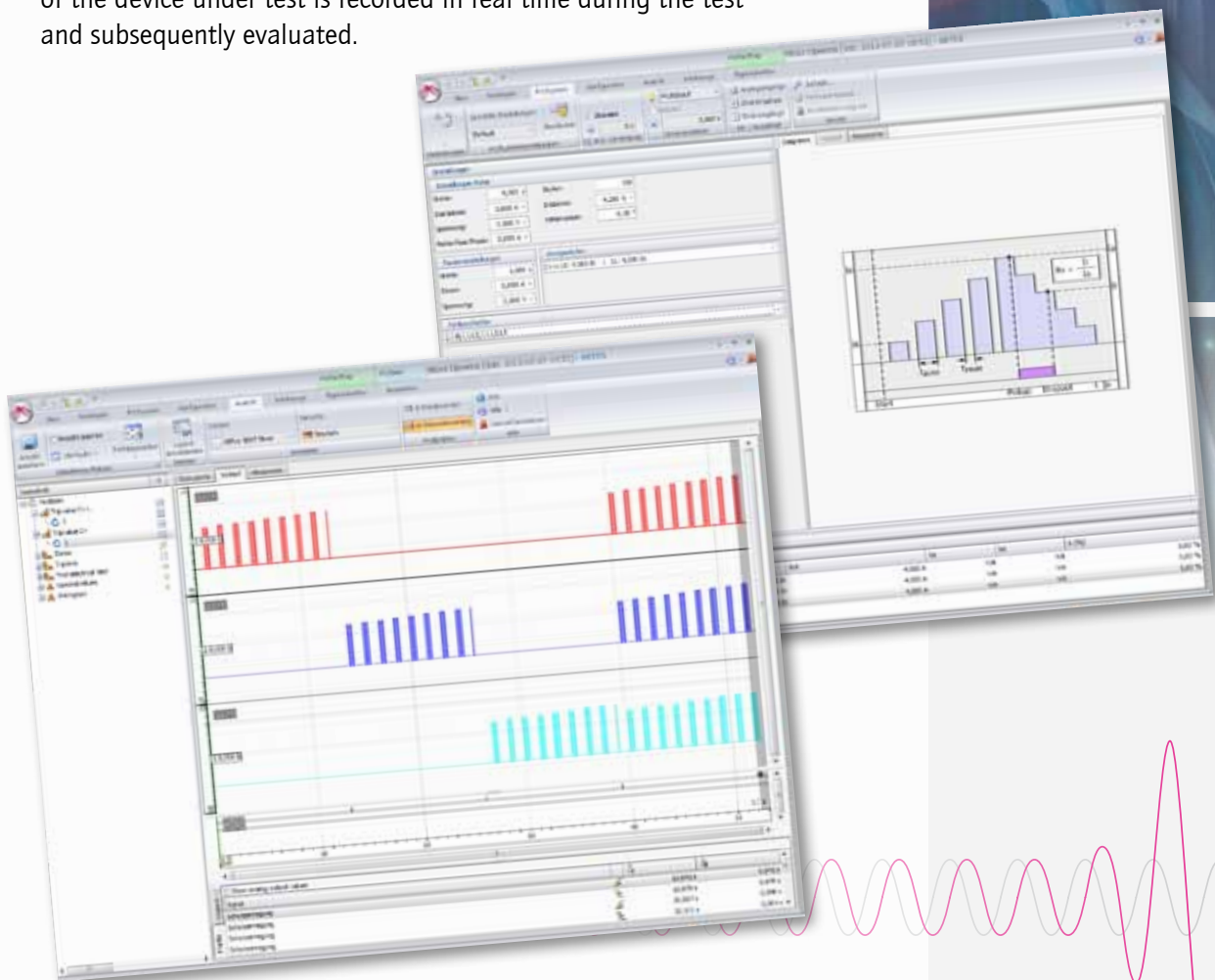

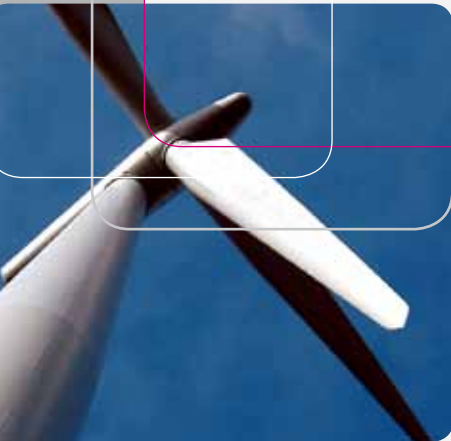

QU-Monitor

Article number 00001274

The Q-U protection function can be tested fully automatically with the QU-Monitor. The QU-Monitor supports various different response characteristics for the Q-U protection function implemented by the manufacturers of protection devices.

As well as verifying the tripping characteristic, it is also possible to check the pick-up and drop-off values of the protection relay for the undervoltage threshold, the minimum current, the minimum reactive power and the angle range of the reactive power direction. Selecting a fault loop makes it possible to reproduce phaseselective fault types as well. This allows the undervoltage threshold and the function of the logical AND-link to be checked in one test step.

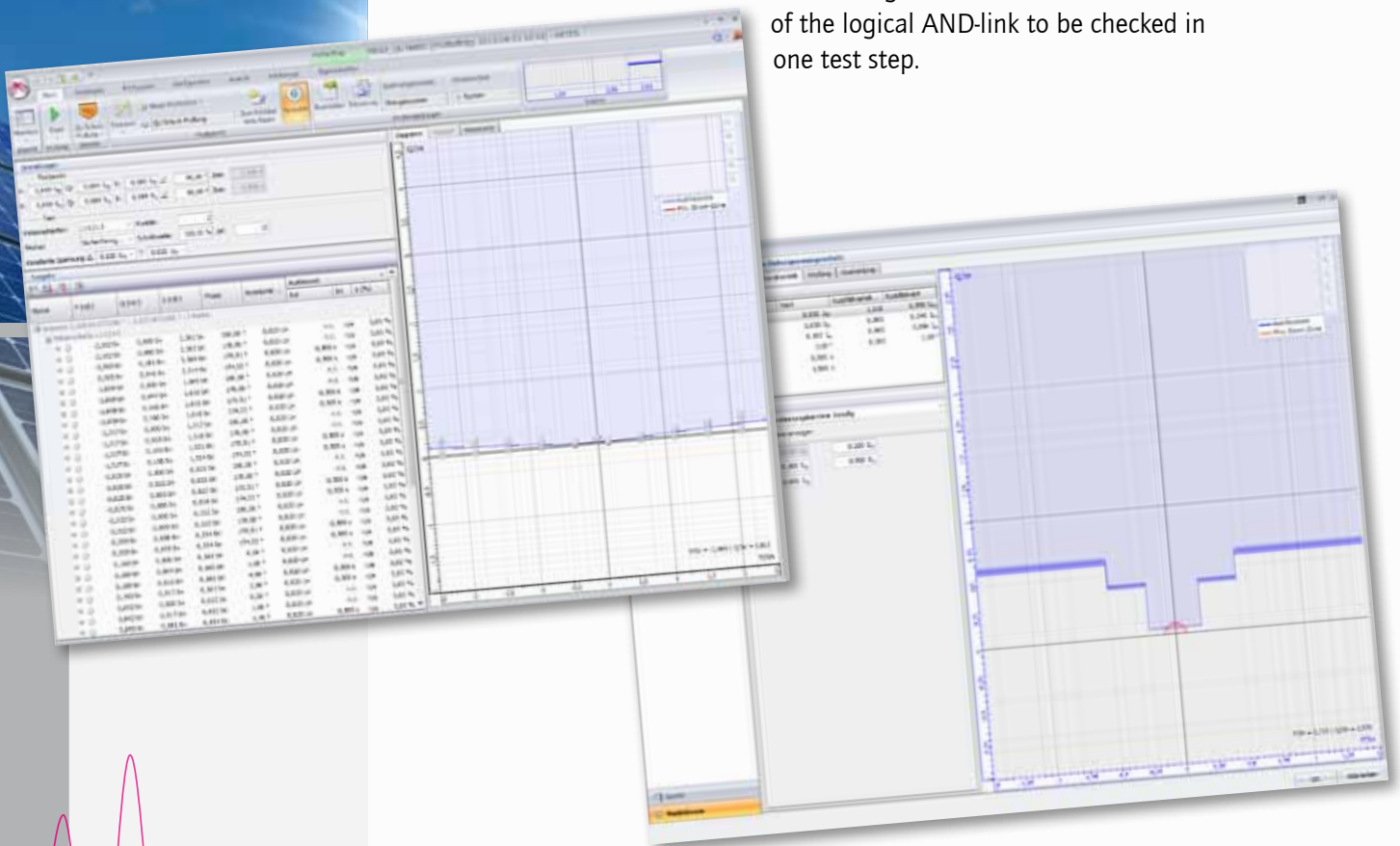

Test monitor overview

Monitor	Test function	Article number
VD	Test any protection function by setting the test quantities manually	Basic software
IT	Check the operating times and directional sensitivity of overcurrent relays	00001253
IMP	Check the operating times and impedance zones of distance protection devices	00001254
TRANSIG	Display and output COMTRADE records and generate any signal characteristic	00001255
SYNC	Test paralleling devices and synchronizers	00001256
DIFF	Check the tripping characteristic and operating times of differential protection relays	00001257
TD	Determine measuring transducer error	00001258
SmartSequencer	Event-controlled output of test sequences	00001259
PIC	Determine the pick-up and drop-off values of protection relays	00001260
QU	Check the Q-U protection function	00001274

Software modules and packages

Software module IEC 61850	<i>Article number 00001261</i>
ARTES 460 560 relay test systems can be integrated in communication according to IEC 61850-8-1. GOOSE telegrams containing trip signals, for example, are picked up and evaluated accordingly.	
Premium software package	<i>Article number 00001264</i>
Consisting of 9 software modules: IT-Monitor, IMP-Monitor, PIC-Monitor, SmartSequencer, DIFF-Monitor, SYNC-Monitor, TD-Monitor, TRANSIG-Monitor, QU-Monitor.	

OPTIONS & ACCESSORIES



Device options

Internal GPS receiver for time synchronisation

Article number 00011522

Internal GPS receiver module for precise time synchronisation. An active GPS antenna with magnetic base, 2 m antenna lead and 10 m antenna extension cord are provided.



Cable sets

Standard cable set SCS 460|560

Article number 00001078

Connecting leads for 4 voltage outputs, 6 current outputs and 4 binary inputs, 20 terminal adapters with insulated 2.5 mm² round Cu-wire for connecting into rail-mounted terminals and 20 plug adapters for connecting safety measuring leads to conventional 4 mm sockets.

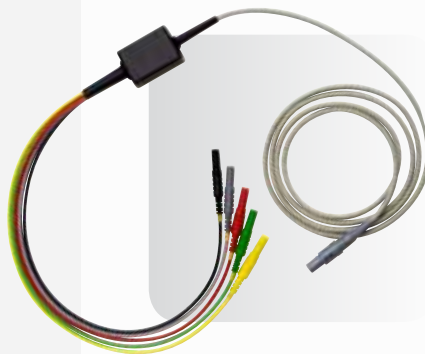

Connection cable LCC for 4 low-level outputs or 4 current measurement inputs

Article number 00001271

The 10 low-level signals generated by ARTES 460|560 can be picked up from three low-level signal outputs on the front panel. The LCC connection cable can be used to make a connection between a device under test and one low-level signal output. The connection cable can also be used to feed up to four signals to the current measurement inputs of the ARTES 460|560 test instruments. The cable is 2 m long. One end of the cable is fitted with a coded push-pull plug for connection to the test instrument; the other end of the cable is fitted with 4 mm safety plugs for connection to the device under test.

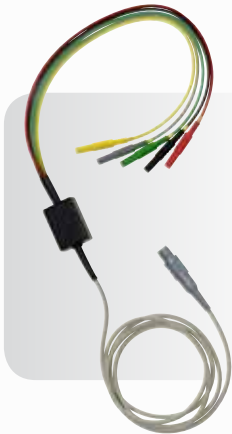

Connection cable VCC for 4 voltage measurement inputs

Article number 00001272

The VCC connection cable can be used to feed up to four signals to the voltage measurement inputs of ARTES 460|560 test instruments. The cable is 2 m long. One end of the cable is fitted with a coded push-pull plug for connection to the test instrument; the other end of the cable is fitted with 4 mm safety plugs for connection to the device under test.



Adapters

Plug adapter PA, 25 pieces

Article number 00001170

Adapter for connecting measuring leads with 4 mm safety plugs to conventional 4 mm sockets.



Terminal adapter TA, 25 pieces

Article number 00001171

Adapter for connecting measuring leads with 4 mm safety plugs to rail-mounted terminals. The adapter converts a 4 mm safety plug to 2.5 mm² round Cu-wire.

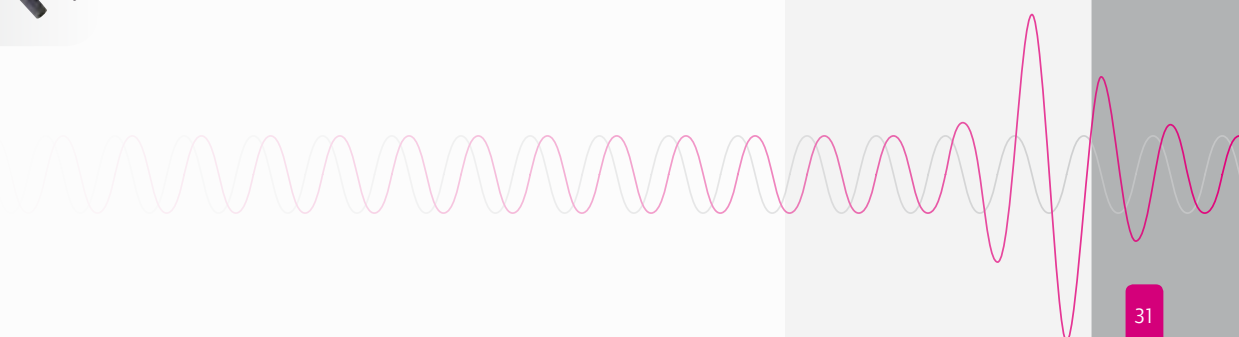
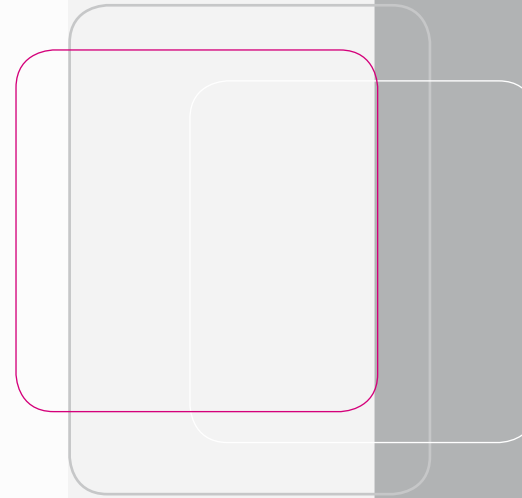

Wrap-around bags & carrying cases



Wrap-around bag for ARTES 460|560

Article number 00006322

Robustly made, lightly padded wrap-around bag with shoulder strap. The bag is fitted with reinforced panels for dimensional stability and features separate compartments for accessories.

External dimensions:
500 x 230 x 360 mm



Carrying case RCS 160 for ARTES 460|560

Article number 00006081

High-quality, robust carrying case with ABS plastic shell, anodised aluminium rim, snap locks and metal hinges. Easy manoeuvrability is provided by the retractable handle and smooth-rolling wheels. The case is delivered complete with a rigid foam insert to snugly fit the device inside.

External dimensions:
600 x 510 x 300 mm
Weight: 6.5 kg



TRAINING COURSES & SEMINARS

Know-how and experience

The construction and smooth operation of protection systems is a task which is becoming more and more complex all the time, so there is a need for specialist training courses and seminars.

Regular product training courses are held at our training centres in Korbach and Weimar, as well as on customers' premises. Special hands-on seminars and workshops which deal primarily with application-related themes round off our training portfolio. The training centres are well equipped with the latest measuring and test equipment for hands-on exercises.



SPECIFICATIONS ARTES 460|560

Signal outputs	THD	< 0.05% ¹⁾		
	Frequency range	DC...3 kHz		
	Transient signals	DC...4 kHz		
	Frequency resolution	0.001 Hz		
	Frequency accuracy	Error < 0.01%		
	Phase angle	0...360°		
	Phase resolution	0.001°		
	Phase accuracy	Error < 0.1° ¹⁾		
Voltage outputs		4 x 0...300 V/75 VA 1 x 0...600 V/150 VA		
	Resolution	13 mV		
	THD	< 0.05% ¹⁾		
	Accuracy	Error < 0.05% ²⁾		
Current outputs		ARTES 460/3	ARTES 460	ARTES 560
		3 x 0...16 A/40 VA	6 x 0...16 A/40 VA	6 x 0...32 A/100 VA
			3 x 0...32 A/80 VA	3 x 0...64 A/200 VA
Resolution	1 mA	1 mA	1 mA	
Accuracy	Error < 0.05% ²⁾	Error < 0.05% ²⁾	Error < 0.05% ²⁾	
Max. output voltage	4 V _{rms} , 6 V _{pk}	4 V _{rms} , 6 V _{pk}	21 V _{rms} , 30 V _{pk}	
Low-level signal outputs	All low-level signal outputs can be set separately and independently of one another as regards phase, amplitude and frequency. The outputs can also be used to control external current and voltage amplifiers.			
	Output range	0...10 V _{pk}		
	Resolution	300 µV		
	THD	< 0.01%		
	Frequency range	DC...3 kHz		
	Transient signals	DC...4 kHz		
	Frequency resolution	0.001 Hz		
	Frequency accuracy	Error < 0.01%		
	Max. output current	20 mA		
	Accuracy	Error < 0.02%		
	Phase angle	0...360°		
	Phase resolution	0.001°		
	Phase accuracy	Error < 0.05°		
DC output	Output range	12...260 V		
	Protection	Overload and short-circuit		
	Output power	50 W (across the entire output range)		
Analog inputs	Frequency range	DC...4 kHz, linear frequency response		
	Accuracy	0.01% ²⁾		
	Protection	Galvanic isolation via opto-couplers or high-speed digital isolators (icoupler®)		
	Voltage range	4 x 0...±10 V / 600 V		
	Current range	4 x 0...±20 mA / 0...±10 V		

1) For the frequency range of 10...200 Hz

2) Of range

Binary inputs	The binary inputs are arranged in groups. The groups can be configured for wet or dry contacts.		
	Number	8	
	Groups	2	
	Activation range	24...300 VDC without range switching for wet contacts	
	Max. measurement duration	Unlimited	
	Protection	Transient protection, polarity protection and galvanic isolation via opto-couplers	
	Sampling rate	8 kHz	
Binary outputs	Number	2	
	Switching capacity AC	0...250 V, 8 A, resistive load	
	Switching capacity DC	0...300 V, $I_{max} = 8$ A, 50 W, resistive load	
	Protection	Potential-free and galvanically isolated output relays	
Operation	PC	ARTES testing software for Windows® 7/8/10	
	Stand-alone	3.5" touch screen, high-resolution, resistive, 2 function keys and jog wheel	
System version	Measurement connections	4 mm safety sockets and multi-pole system sockets on the front panel	
	Interfaces	USB-B, Ethernet (RJ 45)	
	Multi-pole connections	Multi-pole input socket 3 low-level signal sockets	
Power supply	Rated voltage	100...265 VAC / 120...265 VDC	
	Rated frequency	47...63 Hz	
	Wattage	ARTES 460	ARTES 560
		1000 W	2500 W
Housing	Portable 19" housing, 3 U, the carrying handle can also be used as a stand		
	Dimensions (W x H x D) mm	470 x 162 x 326 without handle	
	Weight	ARTES 460	ARTES 560
		10 kg	15 kg
Environment	Operating temperature	0...50°C	
	Storage temperature	-20...60°C	
	Relative humidity	5...90%, non-condensing	
	Protection	IP20	
	Safety standard	EN 61010-1: 2011 300V~CAT III	
	EMC requirements	EN 61326-1: 2013	
	Certification	DAkKS calibration certificate (optional)	

ARTES.



KoCoS Messtechnik AG
Südring 42
34497 Korbach, Germany
Phone +49 5631 9596-40
info@kocos.com
www.kocos.com