

User Manual

APPA 605

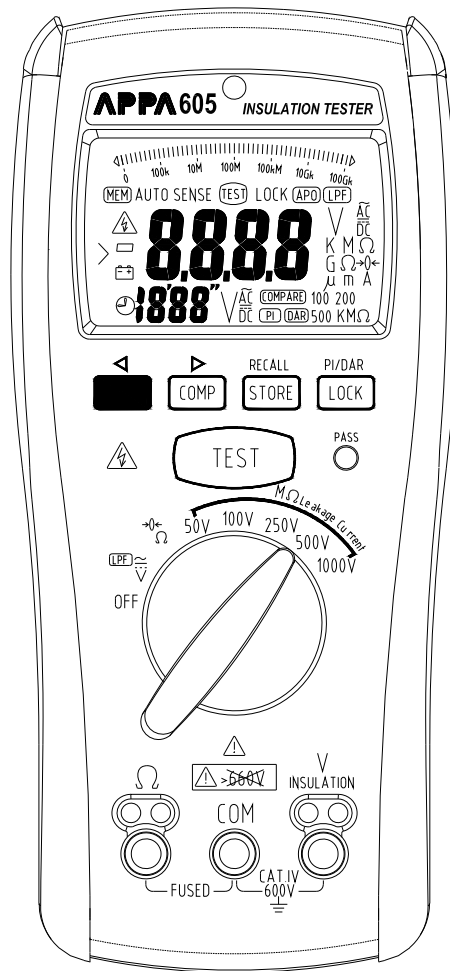

CE

APPA

Advanced Instrument Technology Made Easy

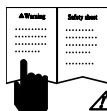

⚠ Read First

⚠ Safety Information

Understand and follow operating instructions carefully. Use the meter only as specified in this manual; otherwise, the protection provided by the meter may be impaired.

⚠ WARNING

Identifies hazardous conditions and actions that could cause **BODILY HARM** or **DEATH**

⚠ CAUTION

Identifies conditions and actions that could **DAMAGE** the meter or equipment under test











⚠ WARNING

- When using test leads or probes, keep your fingers behind the finger guards.
- Remove test lead from Meter before opening the battery door or Meter case.
- Use the Meter only as specified in this manual or the protection by the Meter might be impaired.
- Always use proper terminals, switch position, and range for measurements.
- Verify the Meter's operation by measuring a known voltage. If in doubt, have the Meter serviced.
- Do not apply more than the rated voltage, as marked on Meter, between terminals or between any terminal and earth ground.
- Only replace the blown fuse with the proper rating as specified in this manual.
- Use caution with voltages above 30 Vac rms, 42 Vac peak, or 60 Vdc. These voltages pose a shock hazard.
- To avoid false readings that can lead to electric shock and injury, replace battery as soon as low battery indicator  appears.
- Disconnect circuit power and discharge all high-voltage capacitors before testing resistance, continuity, diodes, or capacitance.
- Do not use Meter around explosive gas or vapor.
- To reduce the risk of fire or electric shock do not expose this product to rain or moisture.

⚠ CAUTION

- Disconnect the test leads from the test points before changing the position of the function rotary switch.
- Never connect a source of voltage with the function rotary switch in Ω , 50V, 100V, 250V, 500V, 1000V position.
- Do not expose Meter to extremes in temperature or high humidity.
- Never set the meter in Ω , 50V, 100V, 250V, 500V, 1000V function to measure the voltage of a power supply circuit in equipment that could result in damage the meter and the equipment under test.

Symbols as marked on the Meter and Instruction manual

	Risk of electric shock
	See instruction manual
	DC measurement
	Equipment protected by double or reinforced insulation
	Battery
	Fuse
	Earth
	AC measurement
	Conforms to EU directives
	Do not discard this product or throw away.

Unsafe Voltage

To alert you to the presence of a potentially hazardous voltage, when the Tester detects a voltage ≥ 2 V in resistance, ≥ 30 V in insulation test, or a voltage overload (OL), the "⚠" symbol is displayed and High voltage indicator is turned on.

Maintenance

Do not attempt to repair this Meter. It contains no userserviceable parts. Repair or servicing should only be performed by qualified personnel.

Cleaning

Periodically wipe the case with a dry cloth and detergent. Do not use abrasives or solvents.

The Meter Description

Front Panel Illustration

1. LCD display : 4000 counts .
2. Push-buttons for features.
3. Rotary switch to turn the Power On or Off and to select a function.
4. Input Terminal for Ω function.
5. Input Terminal for V Insulation functions.
6. Common (Ground reference) Input Terminal for all functions.

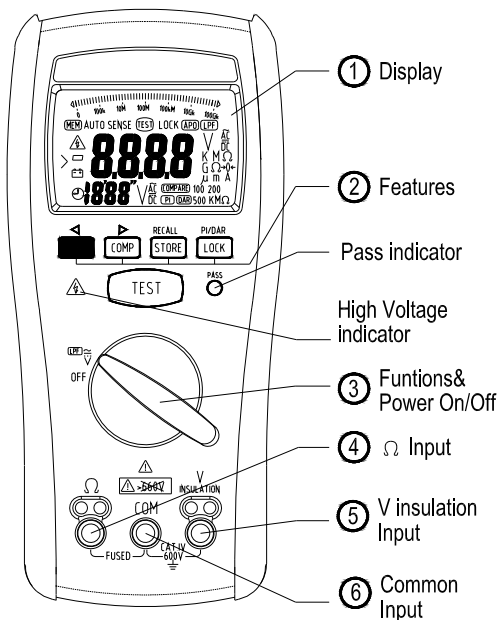

Making Basic Measurements

Preparation and Caution Before Measurement

Δ : Observe the rules of Δ Warnings and Δ Cautions

When connecting the test leads to the DUT (Device Under Test) connect the common (COM) test lead before connecting the live lead ; when removing the test leads removing the test live lead before removing the common test lead.

The figures on the following pages show how to make basic measurements.

Measuring ACV/DCV : Auto sense function

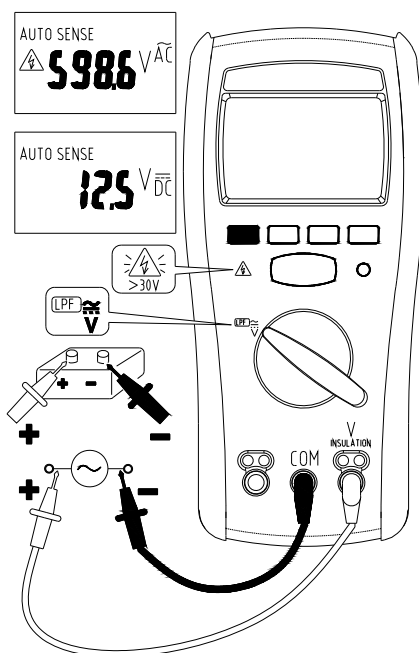

Auto sense mode: The meter displays ACV or DCV whichever is higher (>0.3V).
If the measured voltage is above 660Vac/dc, "> 660Vac/dc" will appear on the display.

Measuring ACV/DCV : Auto sense +LPF function

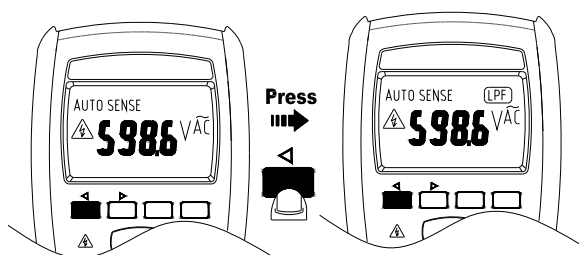

Measuring Earth-Bond Resistance

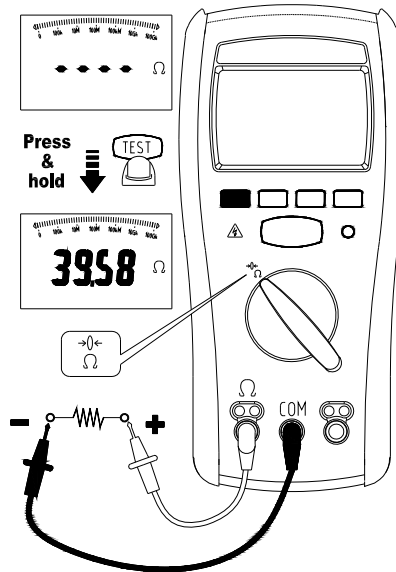

1. Before starting the test :
 - (a) The circuit under test must be completely de-energized.
Check the fuse before testing.
Connecting to an energized circuit while the test is active will blow the fuse.
See Testing the fuse later in this manual.
If the detected voltage is above 2V, ">2V" will appear on the display.
In this condition, the test is inhibited.
 - (b) Short the test leads before measurement, and press the blue button to compensate the probe resistance for <math><2\Omega</math>.
If the probe resistance is stored, "->0<-" symbol will be displayed.
2. Lock mode : Press the Lock button to enter the Lock Mode.
Then press the TEST button to start the test. The test voltage will continue to be applied until the TEST/LOCK button is pressed again.
3. The meter displays the ">" symbol and the maximum resistance for the range when measured resistance is higher than the maximum display range.

Measuring Insulation Resistance

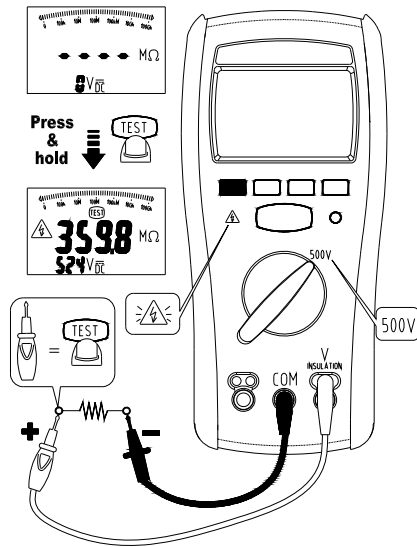

1. Before starting the test :
The circuit under test must be completely de-energized.
If the voltage detected is above 30V, ">30V" will appear on the display. In this condition, the test is inhibited.
2. Press the blue button to display insulation resistance or Leakage current during the test or when the test stops.
3. Lock mode: Press the Lock button to enter the Lock Mode.
Then press TEST button to start the test. The test voltage will continue to be applied until the TEST/LOCK button is pressed again.
4. Release the TEST button before removing the test leads (to enable the tester to discharge capacitive circuits).
If the screen displays volts, wait until it reaches zero.
5. The meter displays the ">" symbol and the maximum resistance for the range when measured resistance is

Using the Compare function

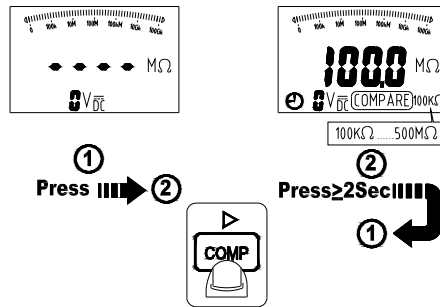

1. Before starting the insulation test :
Press the COMP button to select the compare value among 100kΩ,200kΩ,500kΩ,1MΩ,2MΩ,5MΩ,10MΩ,20MΩ, 50MΩ,100MΩ,200MΩ and 500MΩ.
2. If the measured value is greater than the selected compare value, the green Pass indicator will be turned on.

Measuring PI/DAR

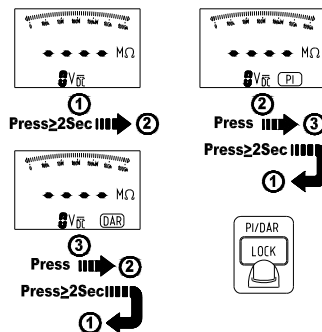

PI(Polarization Index)=R10-min/R1-min

DAR(Dielectric Absorption Ratios)=R1-min/R30-sec

where

R10-min : the insulation resistance measured at the 10 minute after pressing the TEST button.

R1-min : the insulation resistance measured at the 1 minute after pressing the TEST button.

R30-sec : the insulation resistance measured at the 30 second after pressing the TEST button.

If the reading for DAR is bigger than 1.3 or PI is bigger than 2, it indicate a good insulation quality.

When the measured resistance is higher than the maximum range, the screen will display "Err" symbol for PI/DAR value.

TEST button : Press once to start/interrupt the PI /DAR test.

Blue button : Press once during the PI/DAR test to display the time left of the test.

The measured values after the PI test

$PI = R_{10\text{-min}} / R_{1\text{-min}}$

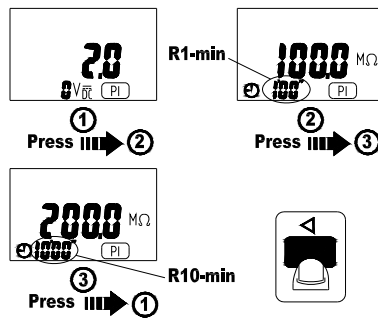

The measured values after the DAR test

$DAR = R_{1\text{-min}} / R_{30\text{-sec}}$

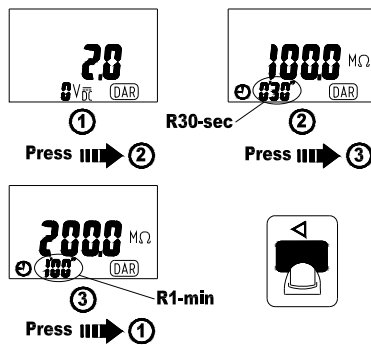

Using the Store function

Store/Recall button :

The screen will be flashing **MEM** symbol and the number of stored data twice when the Store/Recall button is pressed.

1. Press once to store the voltage value during voltage test
2. Press once to store the PI/ DAR, insulation or Earth-bond resistance value when the individual test is completed.
3. The memory is divided into five segments , each segments has 100 maximum data. The method to store the data is first in /first out when the memory is full.

Table: The stored values of the individual test

segments Items	Voltage	Earth-Bond resistance	Insulation resistance 50~1000V	DAR	PI
1	Voltage	Resistance	Resistance	DAR value	PI value
2			Leakage current	R30-sec	R1-min
3			Test voltage	R1-min	R10-min

NOTE :

Press the Store/Recall button ≥ 5 sec to clear the stored data.
The screen will be flashing **MEM** symbol and “cLr” on reading twice.

Using the Recall function

Press the Store/Recall button ≥ 2 sec to enter/exit the RECALL mode.

If the memory is empty, the meter will display the “nOnE ” symbol.

Search the stored value under RECALL mode

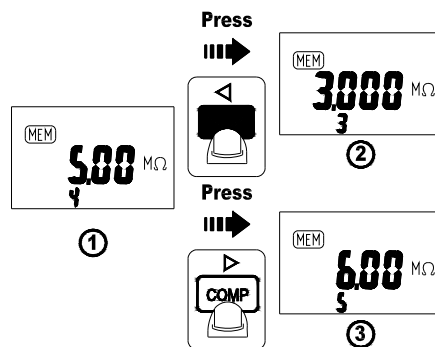

**Read the stored value of insulation test under
RECALL mode**

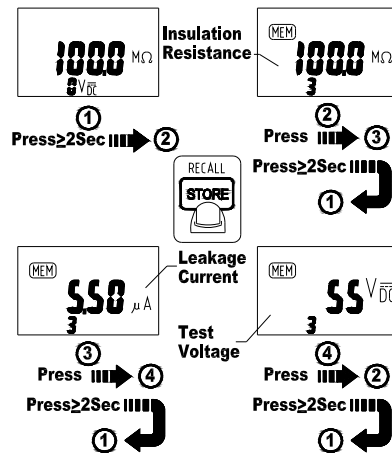

**Read the stored value of DAR test under
RECALL mode**

Press the PI/DAR button ≥ 2 sec to choose the DAR function, and Press the Store/Recall button ≥ 2 sec to enter the RECALL mode.

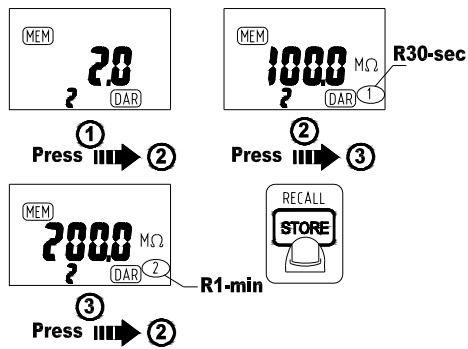

Read the stored value of PI test under RECALL mode

Press the PI/DAR button ≥ 2 sec to choose the PI function,
and Press the Store/Recall button ≥ 2 sec to enter the
RECALL mode.

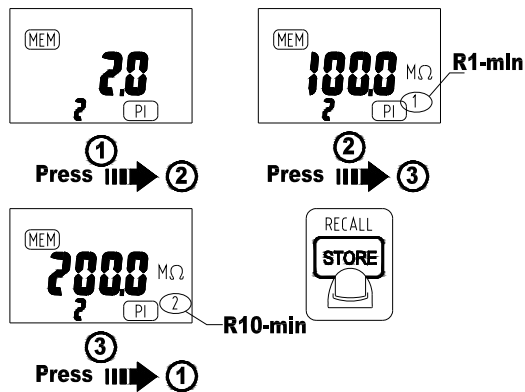

Auto Power Off (Battery Saver)

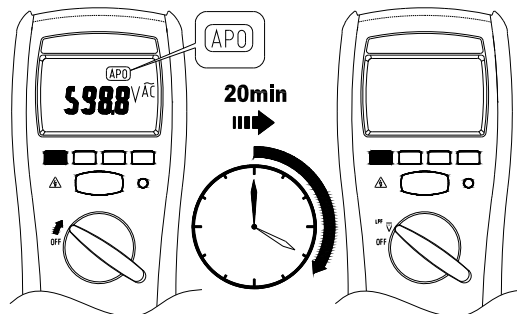

Restore power by switching rotor or pressing any button.

Auto Backlight

The backlight is automatically turned on at dark environment.

BUZZER

The Meter beeps once for every valid key-press, and beeps twice for every invalid key-press.

Power-up options :

Press button while turning meter on from OFF position.

Lock button : display of the software version.

Store button : Reset all stored data

Battery and Fuse Replacement

Refer to the following figure to replace fuse and the batteries :

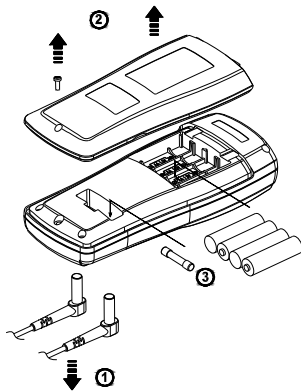

⚠ Caution

- Use only a fuse with the amperage, interrupt, voltage, and speed rating specified.
- Fuse rating : Fast, 315mA, 1000V, Min Interrupt Rating 10000A
- Replace the batteries as soon as the low batteries indicator "⚡" appears, to avoid false reading.
- When the battery is too low for reliable operation, the meter displays "bAtt". The meter will not operate at all until the battery is replaced.
- 1.5V x 4 alkaline batteries.

Testing the fuse

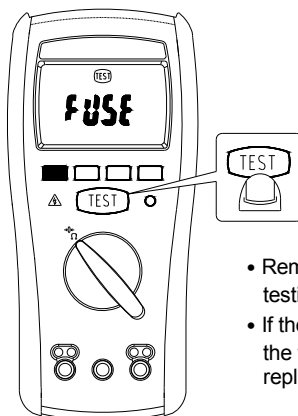

- Remove the test leads before testing the fuse.
- If the display reading is FUSE, the fuse is bad and should be replaced.

Specifications

General Specifications

Maximum voltage applied to any terminal :

600 V ac rms or dc.

Display : 4000 counts.**Polarity Indication :**

Automatic, positive implied, negative indicated.

Overrange Indication : OL**Batteries Life :**

Resistance Measurements : Tester can perform at least 2600 earth-bond resistance measurements with new alkaline batteries at room temperature. These are standard tests of 1Ω with a duty cycle of 5 seconds on and 25 seconds off.

Insulation test: Tester can perform at least 1100 insulation tests with new alkaline batteries at room temperature.

These are standard tests of 1 MΩ at 1000 V with a duty cycle of 5 seconds on and 25 seconds off.

Low Batteries Indication : "⚡" is displayed when the batteries voltage drops below operating voltage.**Low battery voltage :** Approx. 4.5V**Auto Power Off :** Approx 20 minutes.**Operating Ambient : Non-condensing** $\leq 10^{\circ}\text{C}$,

11°C ~ 30°C ($\leq 80\%$ RH),

30°C ~ 40°C ($\leq 75\%$ RH),

40°C ~ 50°C ($\leq 45\%$ RH)

Storage Temperature :

-20°C to 60°C , 0 to 80% R.H. (batteries not fitted)

Temperature Coefficient :

0.15 x (Spec.Accy)/°C, < 18°C or > 28°C .

Measure : Samples 2 times per second nominal.**Altitude :** 6561.7 ft (2000m)**Safety :** Complies with EN61010-1, UL61010-1, IEC 61010-1, V/Ω : CAT.IV. 600V.**CAT****Application field**

I	The circuits not connected to mains.
II	The circuits directly connected to Low-voltage installation.
III	The building installation.
IV	The source of the Low-voltage installation.

Compliance to EN 61557 : IEC61557-1, IEC61557-2, IEC61557-4, IEC61557-10**Weight :** (630g) including battery.

Dimensions (W x H x D) :

95mm x207mm x 52mm with holster.

Accessories : Battery (installed), Test leads and user manual.

Power Requirements : 1.5V x 4 IEC LR6 or AA size.

Pollution degree : 2

EMC : EN 61326-1

Shock vibration : Sinusoidal vibration per MIL-T- 28800E
(5 ~ 55 Hz, 3g maximum).

Drop Protection :

4 feet drop to hardwood on concrete floor.

Indoor Use.

Electrical Specifications

Accuracy is \pm (% reading + number of digits) at 23°C \pm 5°C
< 80%RH.

Voltage Measurement

Function	Range	Accuracy
DCV	600.0V	\pm (1%+5dgt)
ACV	600.0V	\pm (1.5%+5dgt)(50~60Hz) \pm (2%+5dgt)(61~500Hz)
LPF ACV	600.0V	\pm (1.5%+5dgt)(50~60Hz) \pm (5%+5dgt)(61~400Hz)

Start measuring voltage : \geq AC 0.6V.

Over voltage protection : 600V rms or dc.

The cut-off frequency of the low pass filter : 1 kHz.

Input Impedance : 3M Ω // less than 100pF.

**CMRR / NMRR : (Common Mode Rejection Ratio)
(Normal Mode Rejection Ratio)**

V_{AC} : CMRR > 60dB at DC, 50Hz / 60Hz

V_{DC} : CMRR > 100dB at DC, 50Hz / 60Hz

NMRR > 50dB at DC, 50Hz / 60Hz

AC Conversion Type :

AC conversions are ac-coupled, true rms responding,
calibrated to the sine wave input.

For non-sine wave add the following Crest Factor
corrections:

For Crest Factor of 1.4 to 2.0, add 1.0% to accuracy.

For Crest Factor of 2.0 to 2.5, add 2.5% to accuracy.

For Crest Factor of 2.5 to 3.0, add 4.0% to accuracy.

CF 3 @ 330V

2 @ 500V

Earth-bond resistance Measurement

Function	Range	Accuracy
Earth-bond Resistance	40.00Ω	±(1.5%+5dgt)*
	400.0Ω 4000Ω 40.00kΩ	±(1.5%+3dgt)

*<1.00Ω add 3dgt

Open Circuit Test Voltage : >4.0V, <8V

Short Circuit Current : >200.0mA

Live Circuit Detection: if $\geq 2V$ ac/dc at inputs, test inhibited.

Insulation resistance Measurement

Function	Range	Accuracy *
Insulation Resistance	4.000MΩ 40.00MΩ	±(1.5%+5dgt)
	400.0MΩ 4000MΩ	±(3%+5dgt)
	4.1GΩ~20.0GΩ	±(10%+3dgt)

* Above specifications only apply when high quality silicone leads with test clips are being used with no hands touch.

Test Voltage vs. Maximum resistance range :
50V/50.0MΩ, 100V/100.0MΩ, 250V/250.0MΩ, 500V/500MΩ and 1000V/20.0GΩ.

Test Voltage vs. Minimum resistance (with test current=1mA) :
50V/50kΩ, 100V/100kΩ, 250V/250kΩ, 500V/500kΩ and 1000V/1MΩ.

Test Voltage Accuracy : -0%, +20%
Short Circuit Test Current: 1mA(nominal)

Auto discharge function : discharge time < 1 sec for $C \leq 1\mu F$

Maximum Capacitive load : Operable with up to $1\mu F$ load

Live Circuit Detection : if $\geq 30V$ ac/dc at inputs, test inhibited



Limited Warranty

This meter is warranted to the original purchaser against defects in material and workmanship for 1 year from the date of purchase. During this warranty period, Manufacturer will, at its option, replace or repair the defective unit, subject to verification of the defect or malfunction.

This warranty does not cover fuses, disposable batteries, or damage from abuse, neglect, accident, unauthorized repair, alteration, contamination, or abnormal conditions of operation or handling.

Any implied warranties arising out of the sale of this product, including but not limited to implied warranties of merchantability and fitness for a particular purpose, are limited to the above.

The manufacturer shall not be liable for loss of use of the instrument or other incidental or consequential damages, expenses, or economic loss, or for any claim or claims for such damage, expense or economic loss. Some states or countries laws vary, so the above limitations or exclusions may not apply to you.



APPA TECHNOLOGY CORP.
9F.119-1 Pao-Zong Rd., Shin-Tien,
Taipai, 23145, Taiwan, R.O.C.
Tel : 886-2-29178820
Fax : 886-2-29170848
E-MAIL : info @appatech.com
[http ://www.appatech.com](http://www.appatech.com)