

## 1. Safety instructions

### 1.1 Symbols

The symbols in these instructions point out risks and have the following meaning:



Warning in case of risks.  
Non-observance can result in malfunctioning.



Non-observance can result in malfunctioning and personal injury.



Information on proper product handling.

### 1.2 Intended use

- The KINAX 3W2 is a precision instrument. It is used to determine angular positions, processing and providing measured values of electrical output signals for the downstream device. Encoders use for this purpose only.
- The angular position transmitter is not intended to measure rotation speed.
- The device is intended for installation in industrial plants and meets the requirements of EN 61010-1.
- Device versions with explosion protection may only be used in the planned purposes and have to be installed in a housing with an ingress protection of at least IP20 according to EN 60529. The operation in other explosive atmospheres is not permissible.
- Manufacturer is not liable for any damage caused by inappropriate handling, modification or any application not according to the intended purpose.

### 1.3 Commissioning



- Installation, assembly, setup and commissioning of the device has to be carried out exclusively by skilled workers.
- Observe manufacturer's operating instructions.
- Check all electric connections prior to commissioning the plant.
- If assembly, electric connection or other work on the device and the plant are not carried out properly, this may result in malfunctioning or breakdown of the device.
- Safety measures should be taken to avoid any danger to persons, any damage of the plant and any damage of the equipment due to breakdown or malfunctioning of the device.
- Do not operate the device outside of the limit values stated in the operating instructions.
- Operation of device versions with explosion protection is only permissible when...
  - the details on the type label of the device match the on-site conditions for the permissible Ex area in use (group of equipment, equipment category, zone, temperature class or maximum surface temperature)
  - the details on the type label of the device match the electrical supply network
  - the device is undamaged and
  - it has been checked that there is no explosive atmosphere, oils, acids, gases, vapors, radiation etc. present during installation.

### 1.4 Repair work and modifications



Repair work and modifications shall exclusively be carried out by the manufacturer. In case of any tampering with the device, the guaranty claim shall lapse. We reserve the right of changing the product to improve it.

### 1.5 Disposal



The disposal of devices and components may only be realised in accordance with good professional practice observing the country-specific regulations.

### 1.6 Transport and storage



Transport and store the devices exclusively in their original packaging. Do not drop devices or expose them to substantial shocks.

## Operating Instructions

## Transmitter for angular position KINAX 3W2



Camille Bauer Metrawatt AG  
Aargauerstrasse 7  
CH-5610 Wohlen/Switzerland  
Telefon +41 56 618 21 11  
Telefax +41 56 618 21 21  
info@cbmag.com  
www.camillebauer.com



57-3W2 Be 997 223-08 12.14

## 2. Scope of delivery

- Transmitter for angular position KINAX 3W2, acc. made to order
- 3 clamps
- 1 Operating instructions in German, French and English
- 1 Type examination certificate, only with ATEX-approval

## 3. Application

The KINAX 3W2 transmitter converts the angular position of a shaft into a **load independent** direct current signal, proportional to the angular position.

Due to the compact design, the angular position transmitters are particularly suitable for installation in or mounting / on devices and apparatuses.

Explosion-proof "Intrinsically safe Ex ia IIC T6" versions with I.S. measuring output rounds off this series of transmitters.

## 4. Main features

- Compact angular position transmitters for installation or mounting
- Capacitive scanning system
- 0/4...20mA analog output signal with 2-, 3- or 4-wire connection
- Drive shaft without stops, rotating
- Low starting torque
- Non-wearing and low-maintenance
- Wirh explosion prevention „Ex ia IIC T6 Gb“ according to ATEX and IECEx available
- With GL (Germanic Lloyd) available

## 5. Technical data

### 5.1 Measuring input

Measuring ranges:	0... $\geq 5$ to 0... $\leq 270$ $\angle$ ° Preferred range 0...10, 0...30, 0...60, 0...90, 0...180 or 0...270 $\angle$ °
Shaft-diameter	2 mm, 6 mm ans 1/4"
Starting torque:	< 0.001 Ncm [0.0014 oz-in] at 2 mm [0.078"]shaft < 0.03 Ncm [0.0425 oz-in]at 6 mm [0.236"]resp. 1/4" shaft selectable when ordering
Direction of rotation:	

### 5.2 Power supply

DC voltage <sup>1</sup> :	12...33 V (possible with standard version, non-Ex) 12...30 V (necessary with Ex version, type of protection "Intrinsic safety" Ex ia IIC T6)
Max. residual ripple:	10% p.p.
Max. current consumption:	Approx. 5 mA + I <sub>A</sub>

Protection intrinsic safety Ex ia IIC only for connection to certified intrinsically safe circuit with the following maximum values:

max. input voltage U <sub>i</sub> :	30V
max. input current I <sub>i</sub> :	160mA
max. input power P <sub>i</sub> :	1W
max. internal capacitance C <sub>i</sub> :	10nF
max. internal inductance L <sub>i</sub> :	is negligible

<sup>1</sup> Polarity reversal protection. The voltage must not fall below 12 V.

### 5.3 Measuring output

Output variable I <sub>A</sub> :	Load-independent DC current, proportional to the input angle
Standard ranges:	0...1 mA, 3- or 4-wire connection

0...5 mA, 3- or 4-wire connection  
 0...10 mA, 3- or 4-wire connection  
 4...20 mA, 2-wire connection  
 or  
 0...20 mA, 3- or 4-wire connection adjustable with potentiometer  
 4...20 mA, 3- or 4-wire connection

Non-standard ranges:

0... > 1.00 to 0... < 20 mA  
 3- or 4-wire connection

Setting time:

< 3.5 ms

External resistance:

$$R_{\text{ext max.}} [\text{k}\Omega] = \frac{H [\text{V}] - 12 \text{ V}}{I_A [\text{mA}]}$$

H = Power supply

I<sub>A</sub> = Output signal end value

#### 5.4 Accuracy

Reference value:

Measuring range

Basic accuracy:

Limit of error ≤ 0.5% for ranges 0... ≤ 150  $\angle$  °  
 Limit of error ≤ 1.5% for ranges from 0... > 150 to 0...270  $\angle$  °

#### 5.5 Installation Data

Material:

Housing: Metal (aluminium), Surface chromated Alodine 400

Mounting position:

Any

Admissible static loading of shaft:

Sense	Drive shafts dia.	
	2 mm	6 mm resp. 1/4"
radial max.	16 N	83 N
axial max.	25 N	130 N

#### 15.6 Regulations

Spurious radiation:

En 61000-6-3

Immunity:

EN 61000-6-2

Test voltage:

500 Veff, 50 Hz, 1 min.  
 all electrical connections against housing

Common-mode voltage:

100 V, 50 Hz

Housing protection:

IP 50 acc. to EN 60529

#### 5.7 Environmental conditions

Climatic rating:

Standard version  
 Temperature -25 to +70 °C [-13...158° F]  
 Annual mean relative humidity ≤ 90%  
 or  
Version with improved climatic rating  
 Temperature -40 to +70 °C [-40...158° F]  
 Annual mean relative humidity ≤ 95%

Ex version  
 Temperature -40 to +55 °C [-40...131° F] at T6  
 resp. -40 to +70 °C [-40...158° F] at T5  
 resp. -40 to +75 °C [-40...167° F] at T4

Altitude:

2000 m max.

Transportation and storage temperature:

-40 to 80 °C [-40...176° F]

Vibration resistance:

5 g per 2h in 3 directions

Shock resistance:

3x50 g per 10 splicing in all directions

#### 5.8 Operation in potentially explosive environments:

Gas explosion prevention:

Labeling: Ex ia IIC T6 Gb

Conform to standard: ATEX:  
 EN 60079-0:2012  
 EN 60079-11:2012

IECEX:  
 IEC 60079-0:2011  
 IEC 60079-11:2011-06

Type of protection: ia

Temperature class: T6

Group according to EN 60079-00:2012: II

- The operation in other explosive atmospheres is not permissible.
- It is not permissible to make any alteration to equipment that is used in potentially explosive environments.



Devices with explosion prevention must be operated in accordance with the stipulations of the operating instructions. The relevant laws, regulations and standards for the planned application must be observed.

#### 5.9 Dimensional drawing

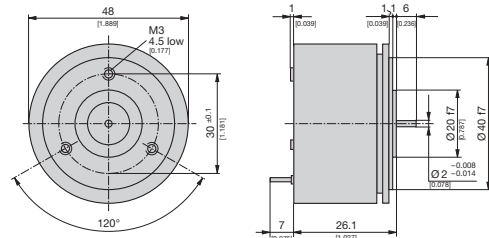

Fig. 1. KINAX 3W2 with standard drive shaft at front only, Ø 2 mm [0.078"], length 6 mm [0.236"].

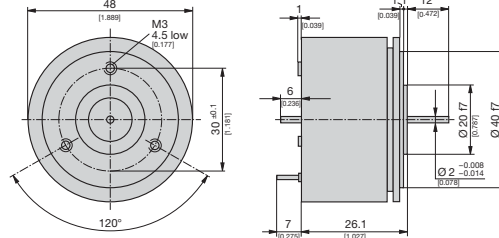

Fig. 2. KINAX 3W2 with special drive shaft at front and at rear. At front: Ø 2 mm [0.078"], length 12 mm [0.472"]. At rear: Ø 2 mm [0.078"], length 6 mm [0.236"].

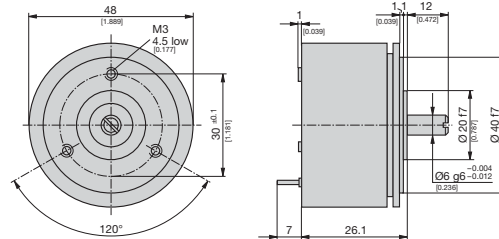

Fig. 3. KINAX 3W2 with special drive shaft at front only, Ø 6 mm [0.236"], length 12 mm [0.472"].

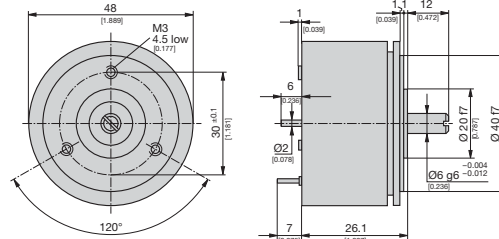

Fig. 4. KINAX 3W2 with special drive shaft at front and at rear. At front: Ø 6 mm [0.236"], length 12 mm [0.472"]. At rear: Ø 2 mm [0.078"], length 6 mm [0.236"].

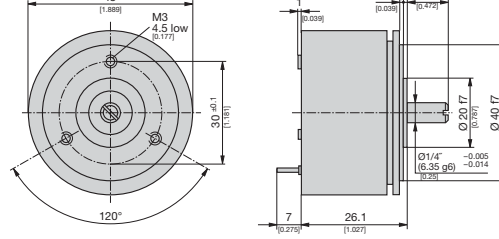

Fig. 5. KINAX 3W2 with special drive shaft at front only, Ø 1/4", length 12 mm [0.472"].

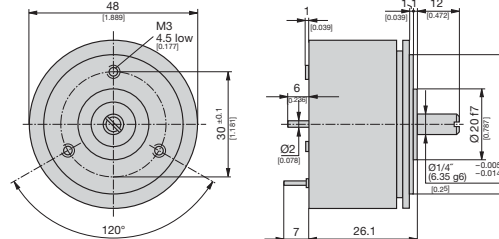

Fig. 6. KINAX 3W2 with special drive shaft at front and at rear. At front: Ø 1/4", length 12 mm [0.472"]. At rear: Ø 2 mm [0.078"], length 6 mm [0.236"].

## 6. Mounting

All six versions of the transmitter (Fig. 1) which differ in appearance by the type of shaft can be mounted either **directly** or by means of **3 mounting clips** to the item being measured. Both methods of mounting and the relevant drilling and cut-out plans can be seen from Table 1.

Table 1:

Mounting versions <sup>2</sup>	Drilling and cut-out diagrams for mounting transmitters
directly	
with 3 clamps	

<sup>2</sup> For the example of KINAX 3W2 with standard drive shaft at front only,  $\varnothing$  2 mm, length 6 mm.

Three **M3** screws are needed for the “**directly**” mounted versions and three **M4** screws for those “**with clamps**”. The screws are not supplied, because the required length varies according to the thickness of the mounting surface.



When deciding where to install the transmitter (measuring location), take care that the “**Ambient conditions**” given in Section “5. Technical data” are **not exceeded**.

Make the cut-out and drill the holes in the item onto which the transmitter is to be mounted according to the **corresponding** drilling and cut-out diagram given in Table 1 and then fit the transmitter.



Pay attention when aligning and tightening the transmitter that the **transmitter zero** and the **zero** of the item being measured **coincide**. Alignment is achieved by rotating the transmitter.

To facilitate alignment in the case of “**direct**” mounting, it is recommended to elongate the 3 mounting holes (diam. 3.2 mm).

When using **mounting clips**, the clips permit the transmitter to be rotated to the correct position.

The **electrical zero** of angular transmitters with measuring ranges **0 to ...**  $\angle$  ° is marked on both the front and the back (see upper illustration). It is only marked on the front, however, in the case of angular transmitters with ranges having a **V characteristic** and at instruments with both senses of rotation, see lower illustration.

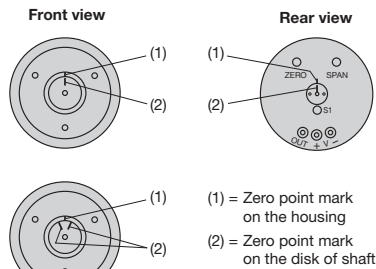

## 7. Electrical connections

### 7.1 Electrical connections via soldering posts

There are 3 soldering posts (3) on the back of the transmitter for attaching the electrical connections (see Fig. 7). The soldering posts suffice Protection Class IP 00 according to EN 60 529.

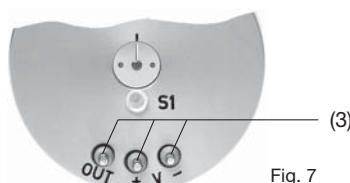

Fig. 7



Note that, ...

... the data required to carry out the prescribed measurement must correspond to those marked on the nameplate of the KINAX 3W2 (Range, Output, Supply voltage)!

... the total loop resistance connected to the output (receiver plus leads) does not exceed the maximum permissible value  $R_{ext.}$ ! See “Measuring output” in Section “5. Technical data” for the maximum values of  $R_{ext.}$ !

... twisted cores must be used for the measured variable input and output leads and routed as far away as possible from power cables!

In all other respects, observe all local regulations when selecting the type of electrical cable and installing them!

In the case of “Intrinsically safe” explosion-proof versions with I.S. measuring output, the supplementary information given on the Ex approval and also local regulations applicable to electrical installations in explosion hazard areas must be taken into account!

Solder the connections as shown in the corresponding wiring diagram (Fig. 8).



Do not excessively heat the soldering posts (3)!  
Solder using a small pencil bit soldering iron!

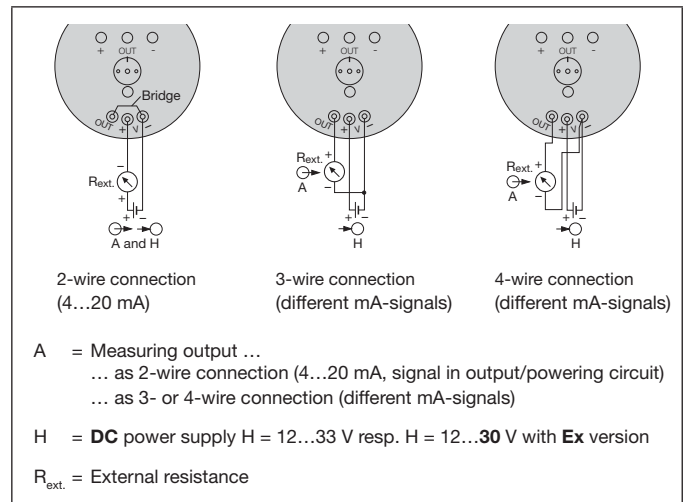

Fig. 8. Connection diagrams for 2-, 3- or 4-wire connection.

### 7.2 Electrical connection via wiring print with pads

There are 3 pads of the transmitter for attaching the electrical connections. For Non-Ex version only.

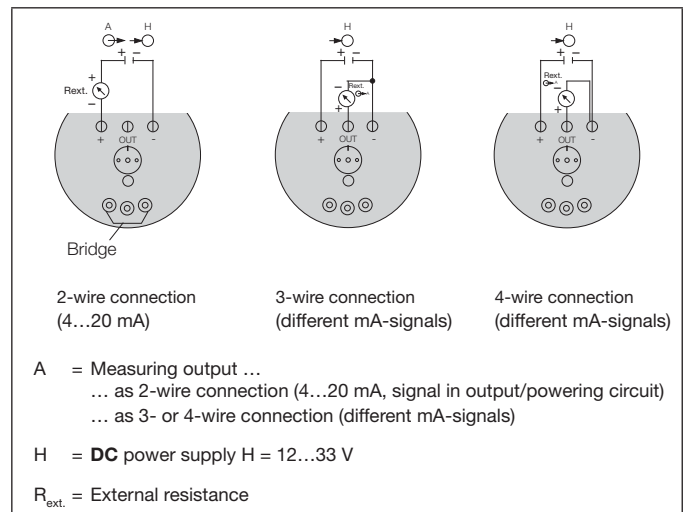

Fig. 9. Connection diagrams for 2-, 3- or 4-wire connection.

### 7.3 Electrical connection via wiring print with screw terminals

There are 4 screw terminals of the transmitter for attaching the electrical connections. For Non-Ex version only.

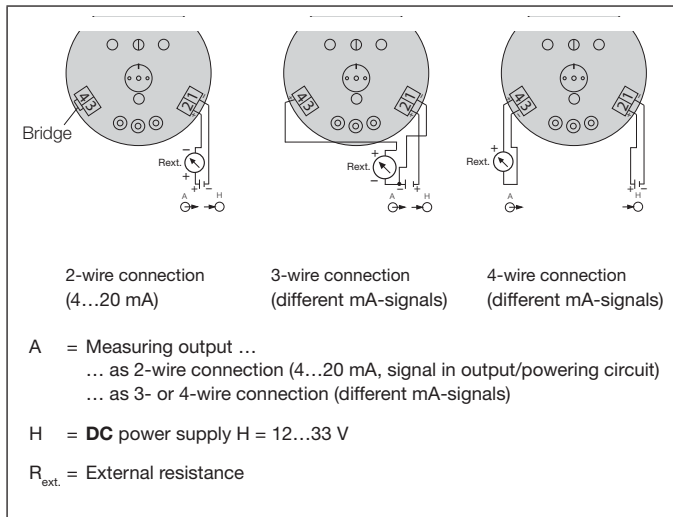

Fig. 10. Connection diagrams for 2-, 3- or 4-wire connection.

### 7.4 Electrical connection via wiring print with AMP-connections

There are 4 AMP-connections of the transmitter for attaching the electrical connections. For Non-Ex version only.

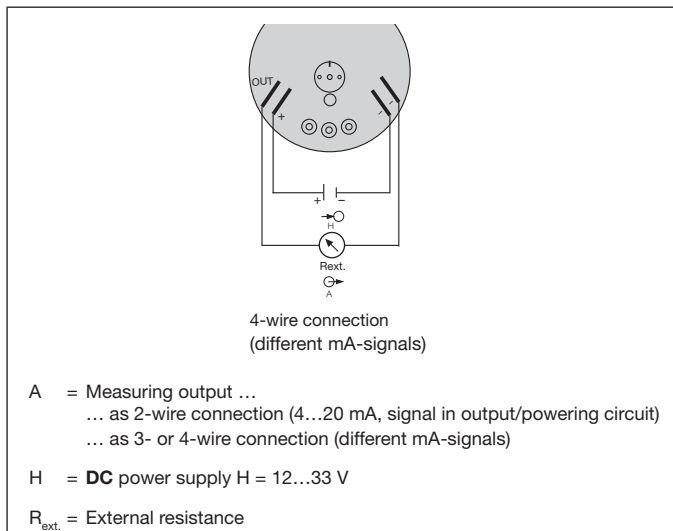

Fig. 11. Connection diagram for 4-wire connection.

### 7.5 Electrical connection via wiring print with trans-zorb-diode

There are 3 pads of the transmitter for attaching the electrical connections. For Non-Ex version only.

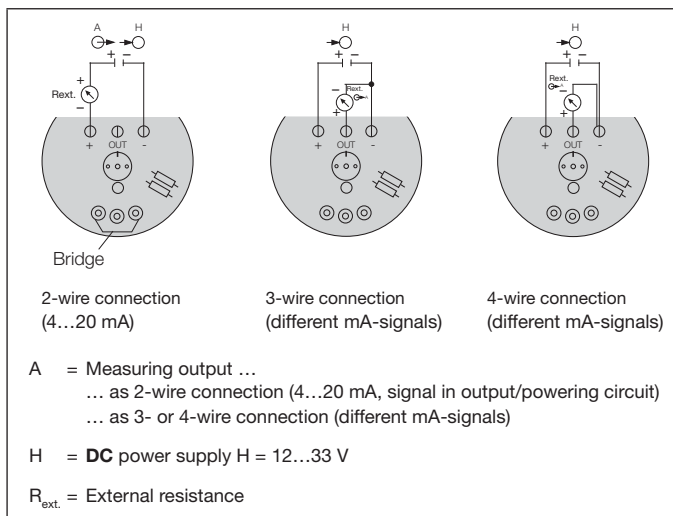

Fig. 12. Connection diagrams for 2-, 3- or 4-wire connection.

### 8. Setting the beginning and end of the measuring range

The coarse adjustment of the beginning of the measuring range consists in aligning the zero of the measured device with the external zero mark on the transmitter. The procedure was described in Section "6. Mounting". This Section concerns the fine adjustment not only of the beginning of the range (ZERO), but also of the end of the scale (SPAN).

Firstly, switch on the power supply to the transmitter.

Remove the ZERO/SPAN sealing plug (4) (Fig. 13, left). Place the measured device at its zero position, i.e. the position at which the KINAX 3W2 should produce 0 mA (3- or 4-wire connection) resp. 4 mA (2-wire connection) at its output.

Should the output current differ by more than 2% from its initial value, repeat the coarse zero setting procedure described in Section "6. Mounting".

Then adjust the "ZERO" potentiometer (Fig. 13, right) using a watchmaker's screwdriver (2.3 mm diam.) so that the desired output current flows.

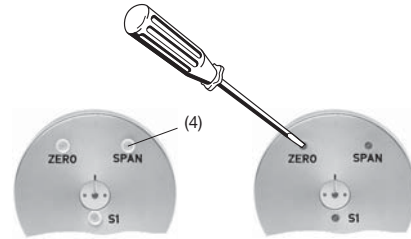

Fig. 13 Adjustments «ZERO», «SPAN» and «S1».

Left: Adjustments covered by the sealing plug (4)  
Right: Adjustments exposed.

Now rotate the measured device to its opposite limite position, i.e. the position at which the KINAX 3W2 should produce the prescribed full-scale output current (see rating plate).

Adjust the "SPAN" potentiometer with the screwdriver as before until precisely the prescribed full-scale output current is measured at the output.

Now recheck the zero value and readjust on the ZERO potentiometer and then recheck the full-scale value.

### 9. Adaptation from 2-wire connection to 3- or 4-wire connection and vice versa

Transmitters with the ordering code 708 - ...D (see Section "4. Specification and ordering information") are designed for either a 2-wire connection with an output range of 4...20 mA or a 3- or 4-wire connection with an output range of 0...20 mA.

If, however, a transmitter be changed from one to the other (see wiring diagrams in Fig. 8, 9, 10 and 12), the beginning and end of the measuring range must be readjusted.

### 10. Reversing the rotation for instruments with measuring ranges > 150 °

A switch is provided on angular transmitters with a measuring range > 150 ° for reversing the direction of rotation. It is marked S1 and can be operated through the opening in the rear part of the transmitter (Fig. 13).

To reverse the direction of rotation, remove the sealing plug (4) covering the switch S1. Then operate the switch by turning it a quarter of a turn with a watchmakers screwdriver (2.3 mm Ø), and reset the beginning and end of the measuring range.

### 11. Electric commissioning

- Provide a separate power supply for the device in case of consumer loads with high interference levels.
- Install the entire plant in an EMC-compatible manner. Installation environment and wiring can affect the EMC of the device.
- For Versions with explosion protection:



The regulations according to EN 60079-14, the equipment safety law, the generally acknowledged rules of the industry and these operating instructions are applicable for installation and operation.

### 12. Maintenance

The device is free of maintenance. Repairs may only be carried out by authorized authorities.

### 13. Specification and ordering information

Significance of the digits 1. to 11.

Description	Order code
<b>1. Version of the transmitter</b> (with standard drive shaft at front <b>only</b> , Ø 2 mm, length 6 mm, see "Note")	<b>708-</b>
Standard version	1
ATEX II 2 G Ex ia IIC T6 Gb version	2
IECEx Ex ia IIC T6 Gb version	A
<b>2. Sense of rotation</b>	
Calibrated for sense of rotation clockwise	1
Calibrated for sense of rotation counterclockwise	2
V characteristic	3
Calibrated for both senses of rotation and marked	4
<b>3. Measuring range</b> (measuring input) $\rightarrow$	
0 ... 10 $\angle$ °	1
0 ... 30 $\angle$ °	2
0 ... 60 $\angle$ °	3
0 ... 90 $\angle$ °	4
0 ... 180 $\angle$ °	5
0 ... 270 $\angle$ °	6
Non-standard 0 ... $\geq$ 5 to 0 ... $<$ 270 $\angle$ °	9
V characteristic	A
<b>4. Output signal</b> (measuring output) $\rightarrow$ / <b>Connection mode</b> (Power supply 12 ... 33 V DC resp. 12 ... <b>30 V</b> DC with <b>Ex</b> version)	
0 ... 1 mA / 3- or 4-wire connection	A
0 ... 5 mA / 3- or 4-wire connection	B
0 ... 10 mA / 3- or 4-wire connection	C
4 ... 20 mA / 2-wire connection or 0 ... 20 mA / 3- or 4-wire connection	D
4 ... 20 mA / 3- or 4-wire connection	E
Non-standard / 3- or 4-wire connection 0 ... $>$ 1.00 to 0 ... $<$ 20 mA	Z
<b>5. Special features</b>	
Without (order code complete)	0
With special feature	1
<b>6. Adjustability</b> (span adjustment)	
Without increased adjustability	0
Increased adjustability + 5% / - 60%	A
<b>7. Drive shaft special</b>	
Standard	0
Dia. 2 mm [0.078"] at front, length 12 mm [0.472"], dia. 2 mm [0.078"] rear, length 6 mm [0.236"]	C
Dia. 6 mm [0.236"] at front, length 12 mm [0.472"]	D
Dia. 6 mm [0.236"] at front, length 12 mm [0.472"], dia. 2 mm [0.078"] rear, length 6 mm [0.236"]	E
Dia. 1/4 " at front, length 12 mm [0.472"]	F
Dia. 1/4 " at front, length 12 mm [0.472"], dia. 2 mm [0.078"] rear, length 6 mm [0.236"]	G
<b>8. Climatic rating</b>	
Without improved climatic rating	0
Improved climatic rating (standard version)	H
Improved climatic rating (Ex/Ex i version)	J
<b>9. Marine version</b>	
Without Version GL ("Germanischer Lloyd")	0
Version GL ("Germanischer Lloyd")	L

Description	Order code
<b>10. Wiring print</b>	
Standard	0
Wiring print with pads	1
Wiring print with screw terminals	2
Wiring print with AMP-connections	3
Wiring print with trans-zorb-diode	4
<b>11. Test protocole</b>	
Without test protocole	0
Protocole German	D
Protocole English	E

### 14. Declaration of conformity

 <b>EG / IEC KONFORMITÄTSERKLÄRUNG</b>  <b>CAMILLE BAUER</b> <b>EC / IEC DECLARATION OF CONFORMITY</b>	
Dokument-Nr. / Document.No.:	<b>WT3w2_CE-konf.DOC</b>
Hersteller / Manufacturer:	<b>Camille Bauer AG</b> Switzerland
Anschrift / Address:	<b>Aargauerstrasse 7</b> CH-5610 Wohlen
Produktbezeichnung / Product name:	<b>Messumformer für Drehwinkel</b> Transmitter for angular position
Typ / Type:	<b>Kinax 3W2</b>
<p>Das bezeichnete Produkt stimmt mit den Vorschriften folgender Europäischer Richtlinien überein, nachgewiesen durch die Einhaltung folgender Normen: The above mentioned product has been manufactured according to the regulations of the following European directives proven through compliance with the following standards:</p>	
<b>Richtlinie / Directive</b>	<b>2004/108/EG(CE)</b> Elektromagnetische Verträglichkeit - EMV-Richtlinie Electromagnetic compatibility - EMC directive
<b>Norm / Standard</b>	<b>EN 61000-6-3: 2007</b> Fachgrundnormen - Störaussendung für Wohnbereich, Geschäfts- und Gewerbebereiche sowie Kleinbetriebe Generic standards - Emission standard for residential, commercial and light-industrial environments <b>EN 61000-6-2: 2005</b> Fachgrundnormen - Störfestigkeit für Industriebereiche Generic standards - Immunity for industrial environments
<b>Prüfungen / Tests</b>	IEC 61000-4-2 IEC 61000-4-3 IEC 61000-4-4 IEC 61000-4-5 IEC 61000-4-6 EN 55011
<b>Richtlinie / Directive</b>	<b>2006/95/EG(CE)</b> Elektrische Betriebsmittel zur Verwendung innerhalb bestimmter Spannungsgrenzen - Niederspannungsrichtlinie - CE-Kennzeichnung : 95 Electrical equipment for use within certain voltage limits - Low Voltage Directive - Attachment of CE marking : 95
<b>Norm / Standard</b>	<b>EN 61010-1: 2001</b> Sicherheitsbestimmungen für elektrische Mess-, Steuer-, Regel- und Laborgeräte - Teil 1: Allgemeine Anforderungen Safety requirements for electrical equipment for measurement, control and laboratory use - Part 1: General requirements
<p>Die explosionsgeschützte Ausführung stimmt mit folgender Richtlinie überein: The explosion protected variant accords to the following directive:</p>	
<b>Richtlinie / Directive</b>	<b>94/9/EG(CE)</b> Geräte und Schutzsysteme zur bestimmungsgemäßen Verwendung in explosionsgefährdeten Bereichen Equipment and protective systems intended for use in potentially explosive atmospheres <a href="http://www.iecex.com/rules.htm">http://www.iecex.com/rules.htm</a>
<b>Norm / Standard</b>	<b>EN 60079-0: 2012 / -11: 2012</b> Explosionsfähige Atmosphäre / Explosive atmospheres - 0: Geräte - Allgemeine Anforderungen / General requirements - 11: Geräteschutz durch Eigensicherheit "i" / Equipment protection by intrinsic safety "i" <b>IEC 60079-0:2011 / -11:2011-06</b> Explosive atmospheres - 0: General requirements - 11: Equipment protection by intrinsic safety "i"
<b>Nachweis / Proof</b>	<b>ZELM 10 ATEX 0427 X</b> Notified Body No. 0102: PTB D-38116 Braunschweig. <b>IECEx ZLM 12.0008 X</b> IECEx QAR: PTB D-38116 Braunschweig.
<p>Ort, Datum / Place, date: Wohlen, 27. März 2013</p> <p>Unterschrift / signature:</p> <p> M. Ulrich Leiter Technik / Head of engineering</p> <p> J. Brem Qualitätsmanager / Quality manager</p>	