

Digital Storage Oscilloscope

SEFRAM 6152, 6154

SEFRAM 6252, 6254

SEFRAM 6352, 6354

USER MANUAL



Table of Contents

SAFETY INSTRUCTIONS	5
GETTING STARTED	13
OSCILLOSCOPE Series Overview...	15
Appearance	20
Set Up	32
QUICK REFERENCE	41
Menu Tree / Operation Shortcuts	43
Default Settings	56
Built-in Help	59
MEASUREMENT	61
Basic Measurement	63
Cursor Measurement	80
Math Operation.....	86
Applications	91
Using Go_NoGo	93
Power Analysis	98
Serial Bus	99
CONFIGURATION	101
Acquisition	103
Display.....	110
Horizontal View	116
Vertical View (Channel).....	121
Trigger	129
System Info / Language / Clock	146
SAVE/RECALL.....	151

File Format/Utility.....	152
Create/Edit file labels	156
Save.....	158
Recall.....	165
Reference Waveforms	170
FILE UTILITIES	173
PRINT OUT	181
REMOTE CONTROL CONFIG.....	185
Interface Configuration	186
MAINTENANCE	193
FAQ	199
APPENDIX	203
OSCILLOSCOPE Specifications	203
Probe Specifications	Erreur ! Signet non défini.
OSCILLOSCOPE Dimensions	209
Declaration of Conformity	Erreur ! Signet non défini.
INDEX	210

S SAFETY INSTRUCTIONS

This chapter contains important safety instructions that you must follow during operation and storage. Read the following before any operation to insure your safety and to keep the instrument in the best possible condition.

Safety Symbols

These safety symbols may appear in this manual or on the OSCILLOSCOPE.



WARNING

Warning: Identifies conditions or practices that could result in injury or loss of life.



CAUTION

Caution: Identifies conditions or practices that could result in damage to the OSCILLOSCOPE or to other properties.



DANGER High Voltage



Attention Refer to the Manual



Protective Conductor Terminal



Earth (ground) Terminal



Do not dispose electronic equipment as unsorted municipal waste. Please use a separate collection facility or contact the supplier from which this instrument was purchased.

Safety Guidelines

General Guideline



CAUTION

- Make sure the BNC input voltage does not exceed 300V peak.
- Never connect a hazardous live voltage to the ground side of the BNC connectors. It might lead to fire and electric shock.
- Do not place any heavy object on the OSCILLOSCOPE.
- Avoid severe impact or rough handling that leads to damaging the OSCILLOSCOPE.
- Do not discharge static electricity to the OSCILLOSCOPE.
- Use only mating connectors, not bare wires, for the terminals.
- Do not block the cooling fan opening.
- Do not perform measurement at a power source or building installation site (Note below).
- Do not disassemble the OSCILLOSCOPE unless you are qualified.

(Measurement categories) EN 61010-1:2001 specifies the measurement categories and their requirements as follows. the OSCILLOSCOPE falls under category II.

- Measurement category IV is for measurement performed at the source of low-voltage installation.
 - Measurement category III is for measurement performed in the building installation.
 - Measurement category II is for measurement performed on the circuits directly connected to the low voltage installation.
 - Measurement category I is for measurements performed on circuits not directly connected to Mains.
-

Power Supply



WARNING

- AC Input voltage: 100 ~ 240V AC, 47 ~ 63Hz, auto selection. Power consumption: 96VA.
- Connect the protective grounding conductor of the AC power cord to an earth ground, to avoid electrical shock.

Cleaning the OSCILLOSCOPE

- Disconnect the power cord before cleaning.
- Use a soft cloth dampened in a solution of mild detergent and water. Do not spray any liquid.
- Do not use chemical containing harsh material such as benzene, toluene, xylene, and acetone.

Operation Environment

- Location: Indoor, no direct sunlight, dust free, almost non-conductive pollution (Note below)
- Relative Humidity: < 80%
- Altitude: < 2000m
- Temperature: 0°C to 50°C

(Pollution Degree) EN 61010-1:2001 specifies the pollution degrees and their requirements as follows. The OSCILLOSCOPE falls under degree 2.

Pollution refers to “addition of foreign matter, solid, liquid, or gaseous (ionized gases), that may produce a reduction of dielectric strength or surface resistivity”.

- Pollution degree 1: No pollution or only dry, non-conductive pollution occurs. The pollution has no influence.
- Pollution degree 2: Normally only non-conductive pollution occurs. Occasionally, however, a temporary conductivity caused by condensation must be expected.
- Pollution degree 3: Conductive pollution occurs, or dry, non-conductive pollution occurs which becomes conductive due to condensation which is expected. In such conditions, equipment is normally protected against exposure to direct sunlight, precipitation, and full wind pressure, but neither temperature nor humidity is controlled.

Storage environment

- Location: Indoor
- Temperature: -10°C to 70°C
40°C /93% RH 60°C /65% RH

Disposal



Do not dispose this instrument as unsorted municipal waste. Please use a separate collection facility or contact the supplier from which this instrument was purchased. Please make sure discarded electrical waste is properly recycled to reduce environmental impact.

Power cord for the United Kingdom

When using the oscilloscope in the United Kingdom, make sure the power cord meets the following safety instructions.

NOTE: This lead/appliance must only be wired by competent persons



WARNING: THIS APPLIANCE MUST BE EARTHED

IMPORTANT: The wires in this lead are coloured in accordance with the following code:

Green/ Yellow:	Earth
Blue:	Neutral
Brown:	Live (Phase)



As the colours of the wires in main leads may not correspond with the coloured marking identified in your plug/appliance, proceed as follows:

The wire which is coloured Green & Yellow must be connected to the Earth terminal marked with either the letter E, the earth symbol  or coloured Green/Green & Yellow.

The wire which is coloured Blue must be connected to the terminal which is marked with the letter N or coloured Blue or Black.

The wire which is coloured Brown must be connected to the terminal marked with the letter L or P or coloured Brown or Red.

If in doubt, consult the instructions provided with the equipment or contact the supplier.

This cable/appliance should be protected by a suitably rated and approved HBC mains fuse: refer to the rating information on the equipment and/or user instructions for details. As a guide, a cable of 0.75mm² should be protected by a 3A or 5A fuse. Larger conductors would normally require 13A types, depending on the connection method used.

Any exposed wiring from a cable, plug or connection that is engaged in a live socket is extremely hazardous. If a cable or plug is deemed hazardous, turn off the mains power and remove the cable, any fuses and fuse assemblies. All hazardous wiring must be immediately destroyed and replaced in accordance to the above standard.



GETTING STARTED

This chapter describes the OSCILLOSCOPE in a nutshell, including its main features and front / rear panel introduction. After going through the overview, follow the Set Up section to properly set up the oscilloscope for first time use. The Set Up section also includes a starter on how to use this manual effectively.



OSCILLOSCOPE Series Overview...	15
Series lineup.....	15
Main Features.....	16
Accessories	17
Package Contents	18
Appearance.....	20
SEFRAM 6152, 6252, 6352 Front Panel.....	20
SEFRAM 6154, 6254, 6354 Front Panel.....	21
Rear Panel.....	27
Display.....	29
Set Up	32
Tilt Stand.....	32
Power Up.....	33
First Time Use	34
How to Use This Manual.....	37

OSCILLOSCOPE Series Overview

Series lineup

The OSCILLOSCOPE series consists of 6 models, divided into 2-channel and 4-channel versions.

Model name	Frequency bandwidth	Input channels	Real-time Sampling Rate
6152	150MHz	2	2.5GSa/s
6252	250MHz	2	2.5GSa/s
6352	350MHz	2	5GSa/s
6154	150MHz	4	5GSa/s
6254	250MHz	4	5GSa/s
6354	350MHz	4	5GSa/s

The 2 channel and 4 channel models differ in the position of the horizontal controls, the math, reference and bus keys as well as the position of the EXT trigger.

2-Channel model

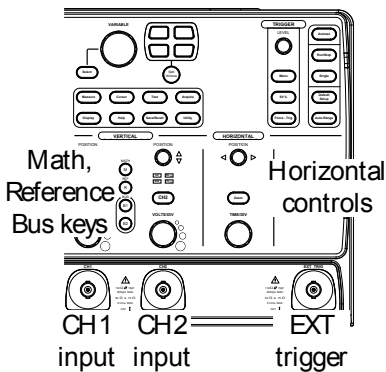

4-Channel model

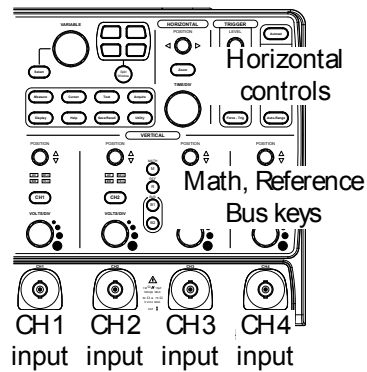

Main Features

Performance	<ul style="list-style-type: none">• High sampling rate: up to 5GSa/s real-time, 100GSa/s equivalent-time• Deep memory: 25k points record length• Minimum 2ns peak detection
Features	<ul style="list-style-type: none">• 2 and 4 channel models• Bandwidth up to 350 MHz• 5GSa/s (200ps resolution) real-time sampling rate• 100GSa/s equivalent sample rate• VPO waveform processing• Large 8" 800 x 600 high-resolution TFT LCD• Unique split window function• Flexible application modules• Three standard input impedances (50Ω/75Ω/1MΩ)• Optional power measurement functions are available for fast analysis of power quality tests• Optional analysis software for I²C, SPI and UART serial signal triggering and decoding• 2 and 4 channel models available up to 350 MHz• Large 8" color TFT LCD, supporting a large 8 x 10 graticule• On-screen Help• 64 MB internal flash memory.• FreeWave remote control software

Interface

- USB host port: front and rear panel, for storage devices
- USB slave port(Optional GPIB to USB), RS-232C port: for remote control
- Calibration output
- Go-No Go output
- Trigger output
- Ethernet port

Accessories

Package Contents

Check the contents before using the OSCILLOSCOPE.

Opening the Box

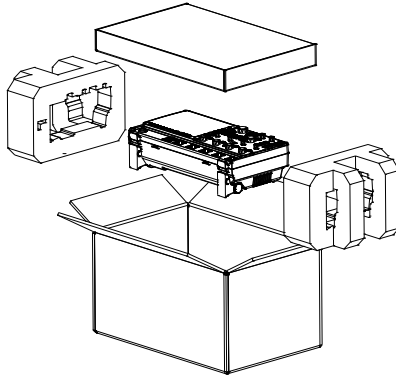

Contents

- Main unit
 - Probe set

 - Power cord
 - User manual on CD-ROM
-

Note

- For detailed probe specifications, see page **Erreur ! Signet non défini..**



Appearance

SEFRAM 6152, 6252, 6352 Front Panel

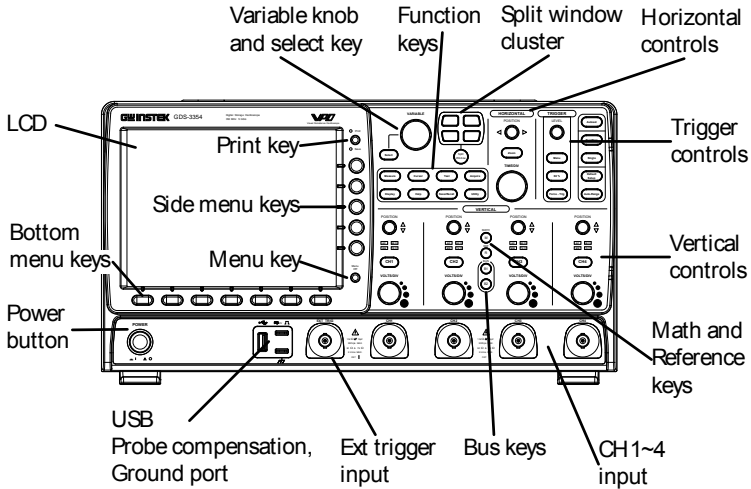

SEFRAM 6154, 6254, 6354 Front Panel

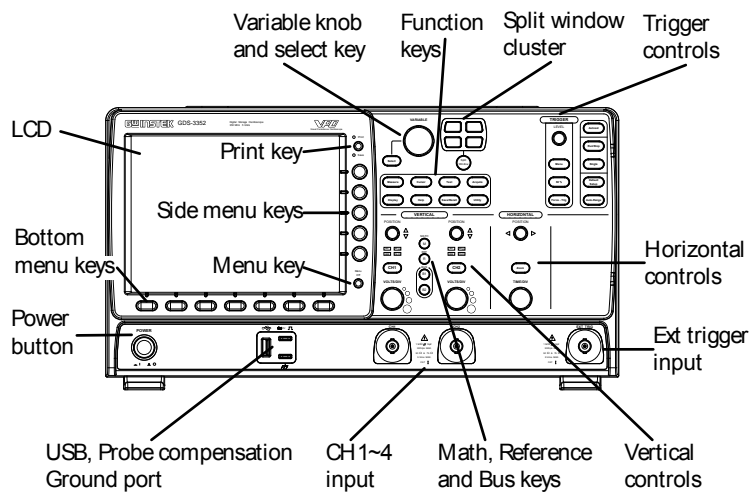

LCD Display 8" SVGA TFT color LCD. 800 x 600 resolution, wide angle view display.

Menu Key **Menu Off** Use the Menu Off key to hide the onscreen menu system.



Side Menu Keys The Side menu and Bottom menu keys are used to make selections from the soft-menus on the LCD user interface.

Bottom Menu Keys

To choose menu items, use the 7 Bottom menu keys located on the bottom of the display panel.

To select a variable or option from a menu, use the Side menu keys on the side of the panel. See page 37 for details.

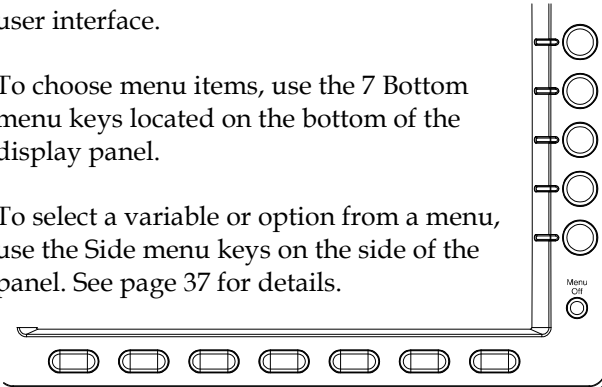

Print Key ○ Print The print key is a quick save or quick print key, depending on its configuration. For more information see pages 160(save) or 182(print).



○ Save

Variable Knob and Select Key

VARIABLE The Variable knob is used to increase/decrease values or to move between parameters.

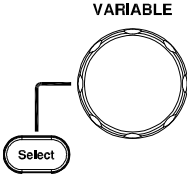

Select The select key is used to make selections.

Split Window Cluster

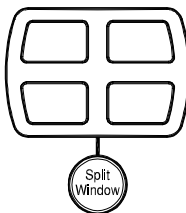

Use the Split Window key to cycle between single and split screen mode. For more details on windowing, see page 70.

Horizontal Controls

The horizontal controls are used to change the position of the cursor, set the time base settings, and to zoom into the waveforms.

Horizontal Position



The Position knob is used to position the waveforms horizontally on the display screen.

Zoom



Press Zoom in combination with the horizontal POSITION knob.

TIME/DIV



The Time/Div knob is used to change the horizontal scale.

Trigger Controls

The trigger controls are used to control the trigger level and options.

Level Knob



Used to set the trigger level.

Trigger Menu Key



Used to bring up the trigger menu.

50% Key























Sets the trigger level to the half way point (50%).

Force - Trig



Press to force an immediate trigger of the waveform.

Autoset		Press the Autoset key to automatically set the trigger, horizontal scale and vertical scale.
Run/Stop Key		Press to Freeze (Stop) or continue (Run) signal acquisition (page65).
Single		Sets the acquisition mode to single triggering mode.
Default Setup		Resets the oscilloscope to default settings.
Auto-Range		Sets the oscilloscope range automatically.
Vertical POSITION	<p data-bbox="371 710 456 730">POSITION</p> 	Sets the vertical position of the waveform.
Channel Menu Key		Press the CH1~4 key to set the channel.
VOLTS/DIV Knob	<p data-bbox="362 948 456 968">VOLTS/DIV</p> 	Sets the vertical scale.
Input Terminals	<p data-bbox="396 1115 452 1136">CH4</p> 	Accepts input signals. Input impedance, selectable: 50Ω, 75Ω, 1MΩ.
Math Key		Use the math key to set and configure math functions.

Reference Key		Press the Reference key to set or remove reference waveforms.
BUS Keys		The Serial bus decode keys are used for UART, I ² C and SPI serial bus interface decoding. The serial bus decode function is an optional extra. See page 98 for details.
Function Keys		The Function Keys are used to enter and configure different functions on the OSCILLOSCOPE.
Measure		Configures and runs automatic measurements.
Cursor		Configures and runs cursor measurements.
Test		Configures and runs applications and optional functions such as the Power Analysis measurement software.
Acquire		Configures the Acquisition mode.
Display		Configures the display settings.
Help		Shows the Help menu.
Save/Recall		Used to save and recall waveforms, images and panel settings.
Utility		Configures the print key, display time, language and calibration.

USB Host Port

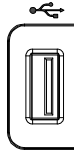

TypeA, 1.1/2.0 compatible. Used for data transfer.

Ground Terminal



Accepts the DUT ground lead for common ground.

Probe Compensation Output



Outputs 2Vp-p, square wave signal for probe compensation (page 195).

External Trigger Input



Accepts external trigger signals (page 129).

Input impedance: $1M\Omega \pm 3\%$,
Voltage input: $\pm 15V$ (peak), EXT trigger capacitance: $\sim 15pF$.

Power Switch

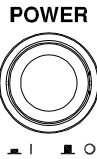

Used to turn the power on/off.

■ I: ON

■ ○: OFF

Rear Panel

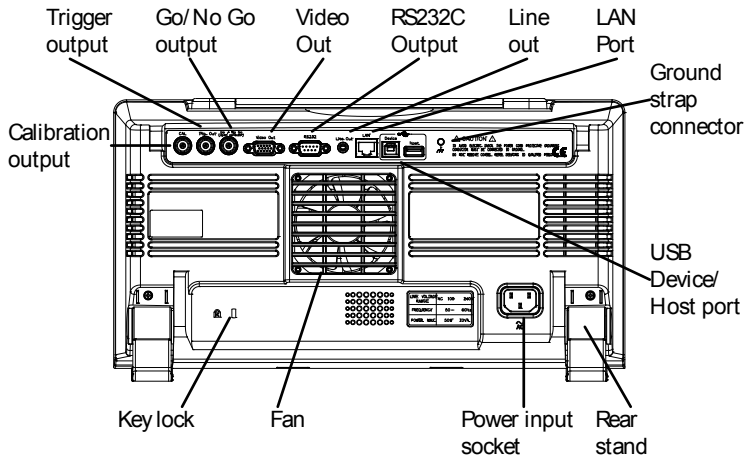

Calibration
Output



Outputs the signal for vertical scale accuracy calibration (page 193).

Trigger Output



Outputs the trigger timing.

Go-No Go
Output



Outputs Go-No Go test results (page 91) as 10us pulse signal.

Video Out



Outputs SVGA resolution to an external display.

RS232

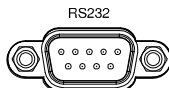

RS232 remote control.

Line Out



Audio line out.

LAN Port

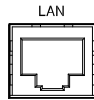

Ethernet port.

Ground Strap
Connector



For use with a grounding strap.

USB Device Port



The USB device port is used for remote control and for the FreeWave remote control software. USB 1.1/2.0 high speed compatible.

USB Host



The USB host port supports USB flash drives for external memory. USB 1.1/2.0 high speed compatible.

Security Slot



Kensington security slot compatible.

Power Input
Socket

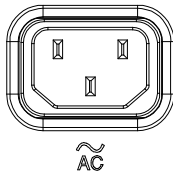

Power cord socket accepts AC mains, 100 ~ 240V, 50/60Hz.

For power up sequence, see page 33.

Display

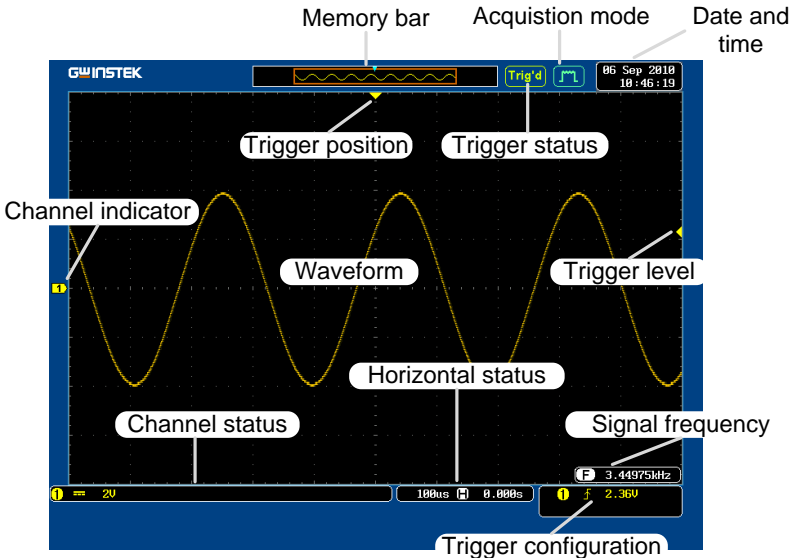

Waveforms

Shows input signal waveforms.

Channel 1: Yellow

Channel 2: Blue

Channel 3: Pink

Channel 4: Green

Channel Indicator

The channel indicator shows the zero volt level of the signal waveform for each activated channel. The active channel is shown with a solid color.

M Math

B1 Bus (B1)

3 Active channel (CH3)

1 Reference waveform (Ref1)

4 Activated channel (CH4)

Trigger Position

Shows the position of the trigger.

Horizontal Status

Shows the horizontal scale and position.

Date and Time  Current date and time (page 148).

Memory Bar

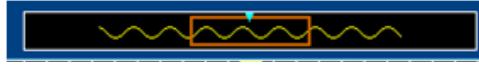

The ratio and the position of the displayed waveform compared with the internal memory (page 116).

Trigger Status



Triggered.



Not triggered, display not updated.



Trigger stopped. Also appears in Run/Stop (page65).



Roll mode.



Auto trigger mode.

For trigger details, see page 129.

Acquisition Mode



Normal mode



Peak detect mode



Hi Resolution



Average mode

For acquisition details, see page 103.

Signal Frequency

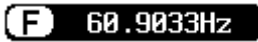

Shows the trigger source frequency.



Indicates the frequency is less than 2Hz (lower frequency limit).

Trigger
Configuration

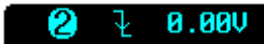

Trigger source, slope,
voltage.



Trigger source, trigger
(video), field, line.

For trigger details, see page 129.

Channel Status



Channel 1, inverted, AC
coupling, 1V/Div



Channel 1, GND coupling,
1V/Div

For channel details, see page 121.

Set Up

Tilt Stand

Upright

Turn the legs under the casing as shown below to have the instrument sit upright.

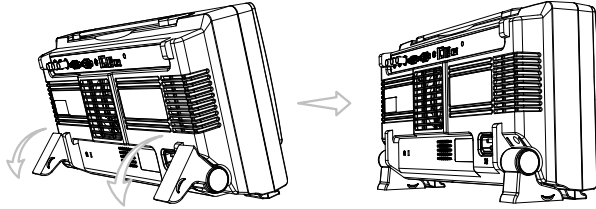

Tilt

To tilt, tilt the legs back behind the casing, as shown below.

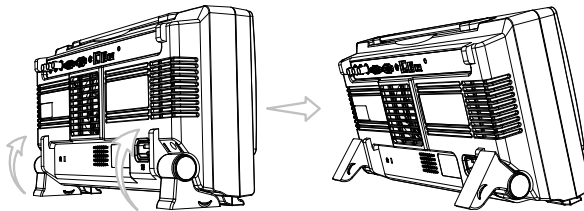

Power Up

Step

1. Connect the power cord to the rear panel socket.

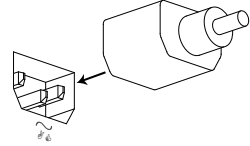

2. Press the POWER key. The display becomes active in ~ 30 seconds.

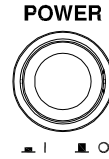

■ I: ON

■ ○: OFF

Note

The OSCILLOSCOPE recovers the state right before the power is turned OFF. The default settings can be recovered by pressing the Default key on the front panel. For details, see page 165.

First Time Use

Background This section describes how to connect a signal, adjust the scale, and compensate the probe. Before operating the OSCILLOSCOPE in a new environment, run these steps to make sure the instrument performs at its full potential.

1. Power On Follow the procedures on the previous page.

2. Set the Date and Time Set the date and time. Page 148

3. Reset System Reset the system by recalling the factory settings. Press the *Default Setup* key on the front panel. For details, see page 165.



4. Install Optional Software The optional software packages (Power Analysis, Serial Bus Decode) can be activated. Page 197

5. Connect Probe Connect the probe to the Channel1 input terminal and probe compensation signal output (2Vp-p, 1kHz square wave).
Set the probe attenuation to x10 if the probe has adjustable attenuation.

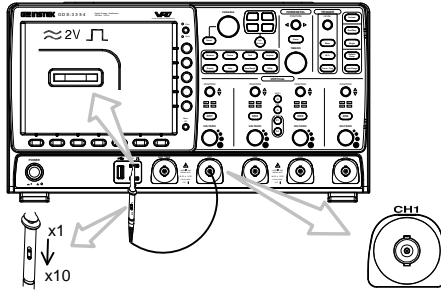

6. Capture Signal (Autoset)

Press the *Autoset* key. A square waveform appears on the center of the screen. For Autoset details, see page 64.

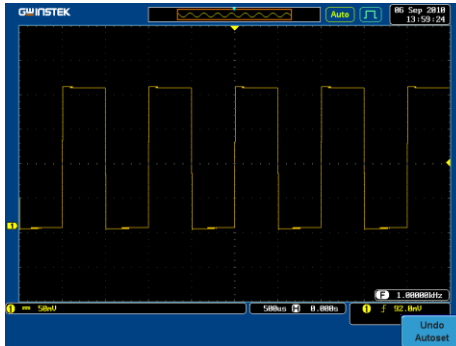

7. Select Vector Waveform

Press the *Display* key, and set the display to *Vector* on the bottom menu.

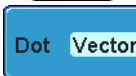
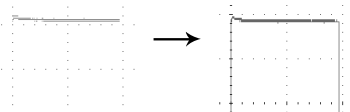

8. Compensate Probe

Turn the adjustment point on the probe to make the square waveform edge flat.

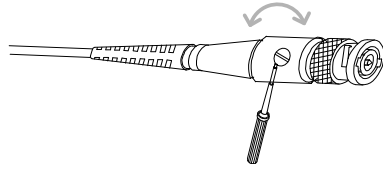
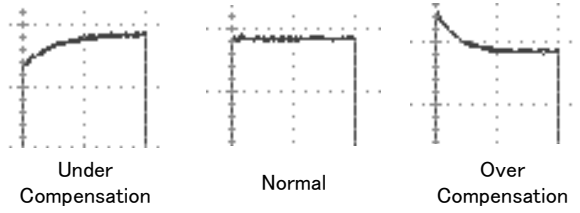

9. Start Operation

Continue with the other operations.

Measurement: page 60 Configuration: page 91

Save/Recall page 151 File Utilities page 171

Print Out 181 Remote Control page 185

How to Use This Manual

Background This section describes the conventions used in this manual to operate the OSCILLOSCOPE.

Throughout the manual any reference to pressing a menu key refers to the keys directly below or beside any menu icons or parameters.

When the user manual says to “toggle” a value or parameter, press the corresponding menu item. Pressing the item will toggle the value or parameter.

Active parameters are highlighted for each menu item. For example in the example below, Coupling is currently set to DC.

If a menu item can be toggled from one value or parameter to another, both options will be visible, with the current option highlighted. In the example below the slope can be toggled from a rising slope to a falling slope.



Selecting a Menu Item or Parameter

When the user manual says to “select” a value from one of the side menu parameters, first press the corresponding menu key and use the variable knob to either scroll through a parameter list or to increase or decrease a variable.

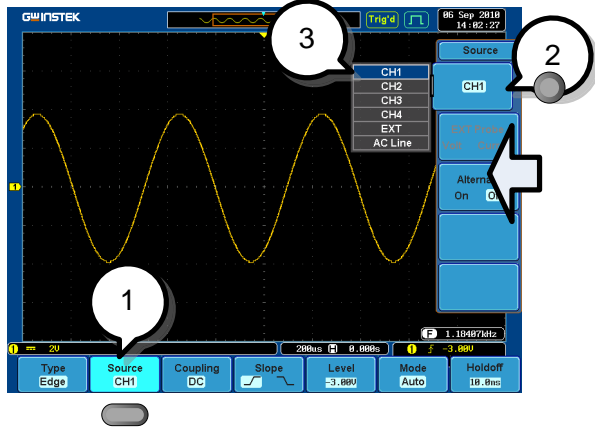

Example

1. Press a bottom menu key to access the side menu.
2. Press a side menu key to either set a parameter or to access a sub menu.
3. If accessing a sub menu or setting a variable parameter, use the variable knob to scroll through menu items or variables. Use the select key to confirm and exit.
4. Press the same bottom menu key again to reduce the side menu.

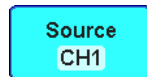
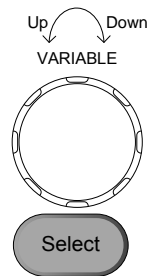
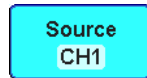

Toggle a Menu Parameter

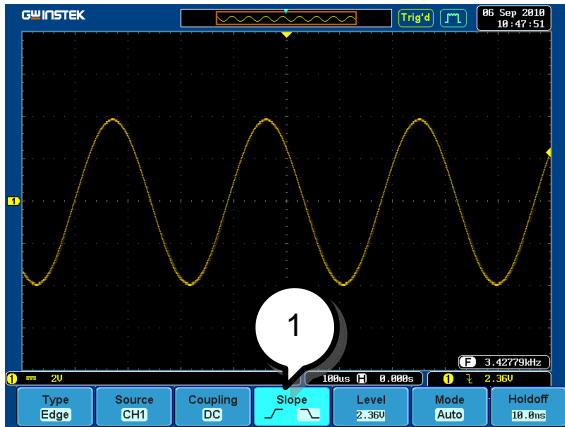

1. Press the bottom menu key to toggle the parameter.

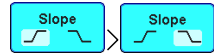

Reduce Lower Menu

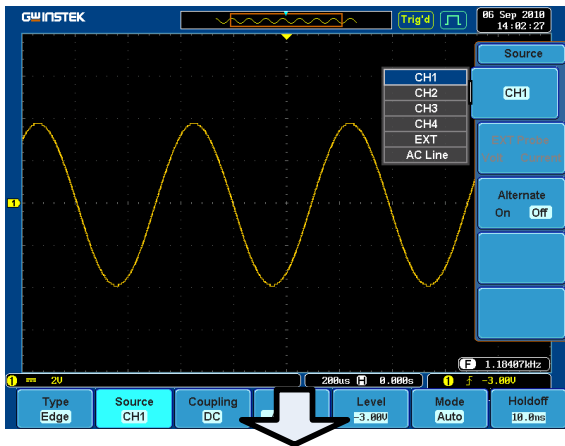

1. Press the relevant function key again to reduce the bottom menu. For example: press the trigger menu key to reduce the trigger menu.

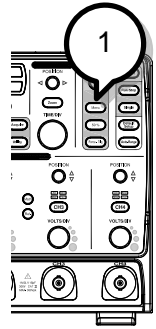

Remove All Menus

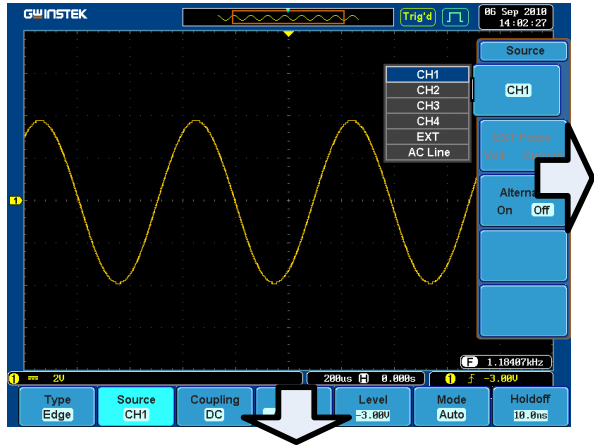

1. Press the Menu Off key to reduce each menu level.

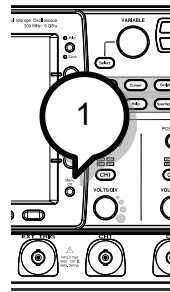

QUICK REFERENCE

This chapter describes the OSCILLOSCOPE menu tree, shortcuts to major operations, built-in Help access, and default factory settings. Use them as a handy reference to get a quick access to the functionality.

Menu Tree / Operation Shortcuts	43
Convention	43
Acquire Key.....	44
Autoset Key.....	44
Auto-Range.....	44
CH1 ~ 4 Key.....	45
Cursor Key	45
Display Key	46
Help Key	46
Math Key	47
Measure Key.....	48
Print/Save Key	49
Run/Stop Key.....	49
REF Key	49
Save/Recall Key.....	50
Test Key.....	51
Test Key – Go-NoGo	51
Trigger Type Menu	52
Trigger Edge Menu	52
Trigger Delay Menu	52
Trigger Pulse Width Menu.....	53
Trigger Video Menu.....	53
Trigger Pulse Runt Menu.....	53
Trigger Rise & Fall Menu.....	54

Utility Key 54
Utility Key – I/O..... 55
Utility Key – File Utilities..... 55
Utility Key – Self Calibration..... 55
Zoom Key..... 56

Default Settings.....57

Built-in Help59

Menu Tree / Operation Shortcuts

Convention

For all menu trees, bottom menu keys are shown as grey icons and side menu keys are shown in white. All menu tree operations are shown in order from top to bottom.

Below is an example of the menu tree operation for the trigger source menu and a comparison to the operation on the DSO screen.

Menu Tree

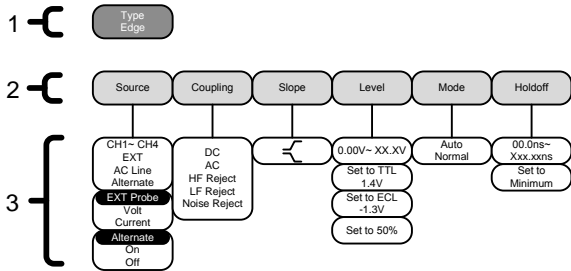

On Screen Menu

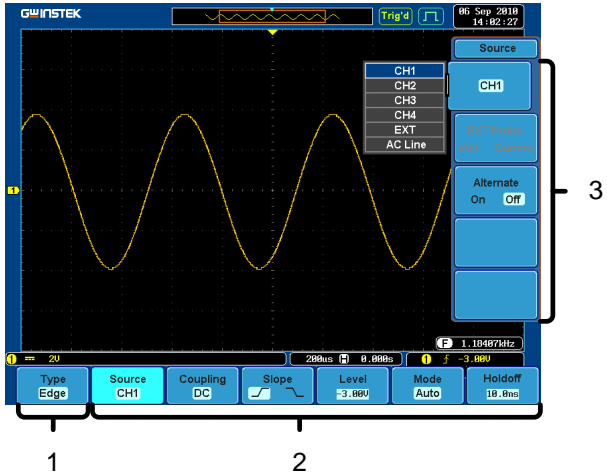

Acquire Key

Sets the acquisition mode.

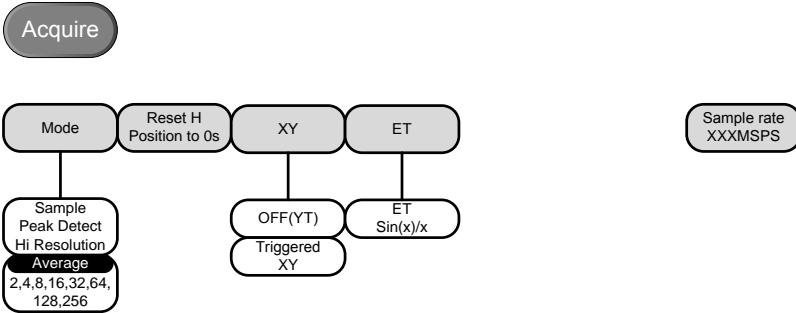

Autoset Key

Automatically finds the signal and sets the horizontal and vertical scale.



Auto-Range

Constantly adjusts the vertical and or horizontal scale.

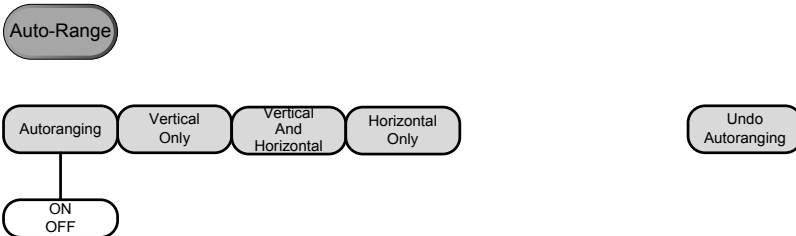

CH1 ~ 4 Key

Set the channel input parameters.

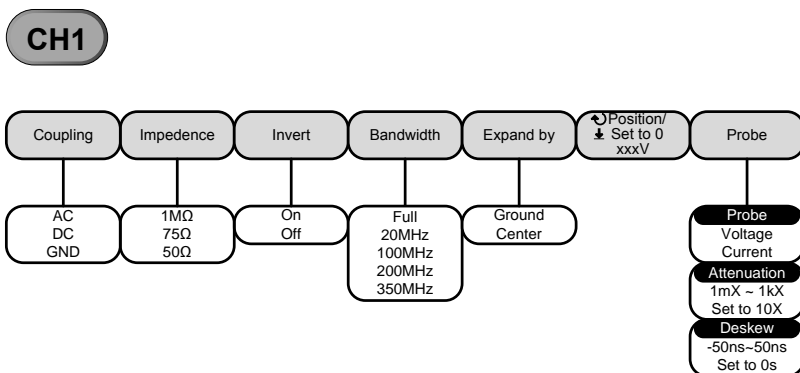

Cursor Key

Set cursor positions.

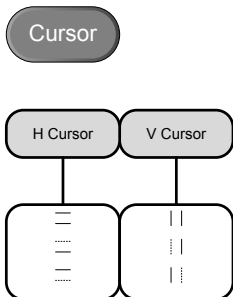

Display Key

Set the display properties.

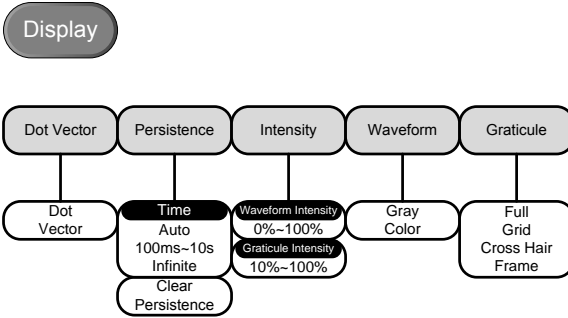

Help Key

Turn help mode On/Off.



Math Key



Standard math and FFT functions.

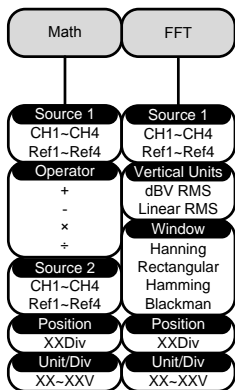

Measure Key

Display automatic measurements either individually or as voltage/current, time or delay measurement groups.

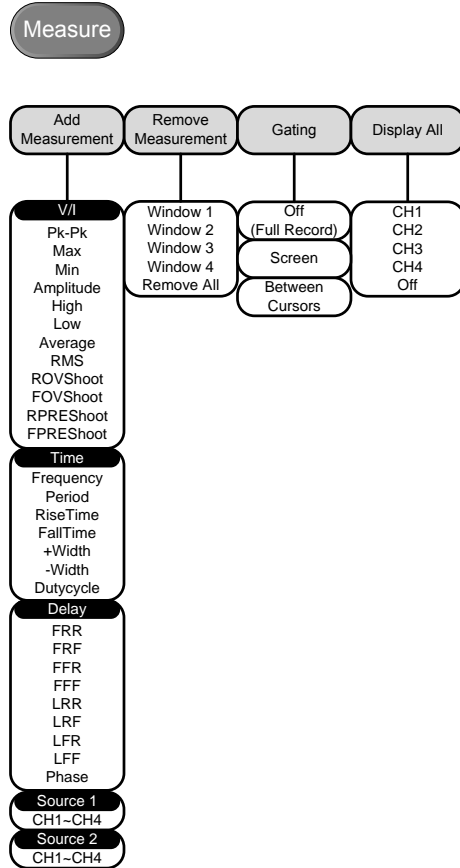

Print/Save Key

- Print Print or save screen images.



- Save

Run/Stop Key



Freeze/unfreeze signal acquisition

REF Key

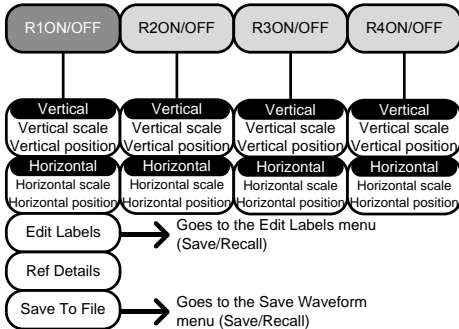

Save/Recall Key

Save and recall images, waveforms and panel setups. Edit labels for reference and setup files.

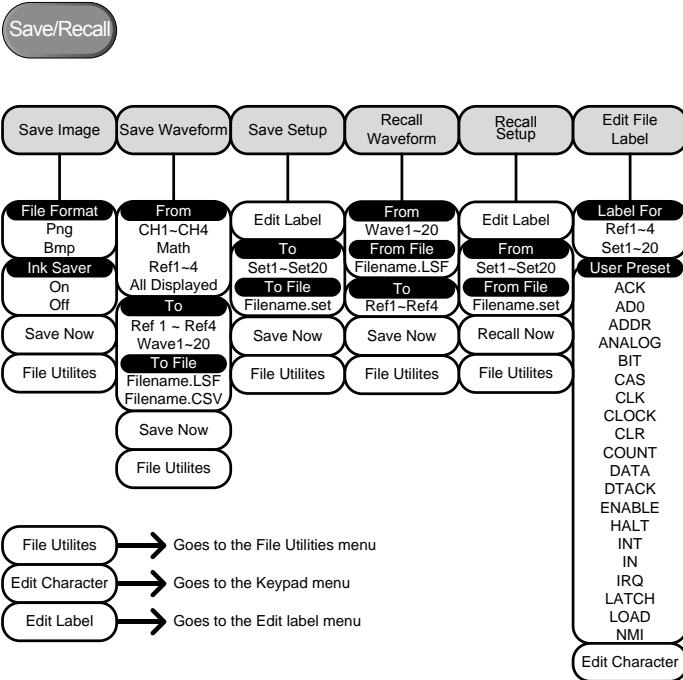

Test Key

Use the Go-NoGo application as well as additional optional software such as the Power Analysis software.

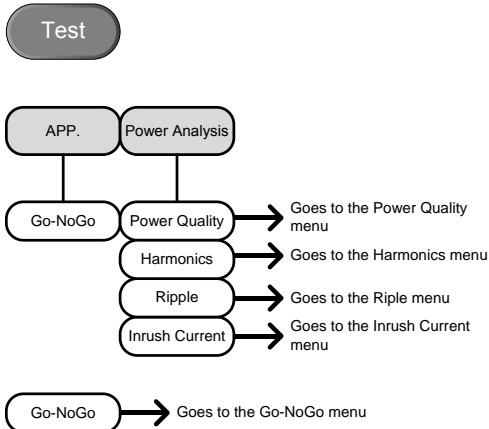

Test Key – Go-NoGo

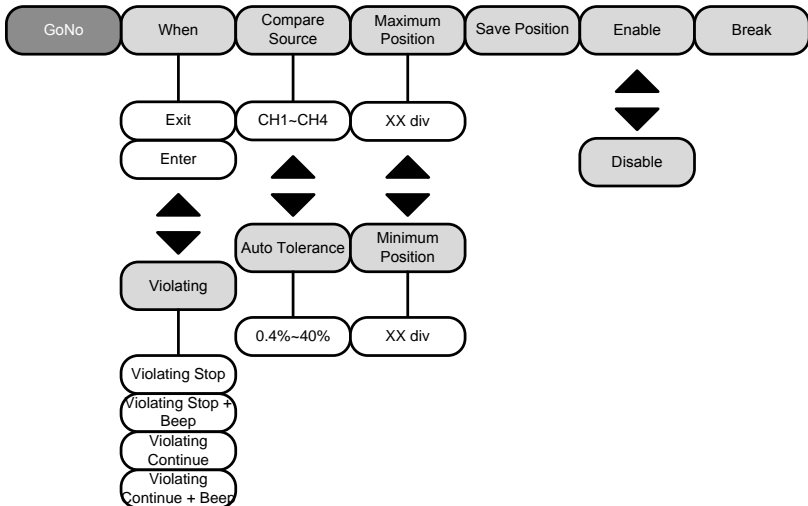

Trigger Type Menu

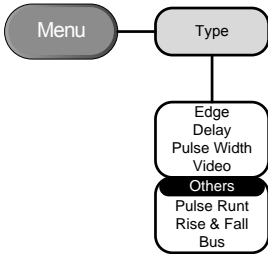

Trigger Edge Menu

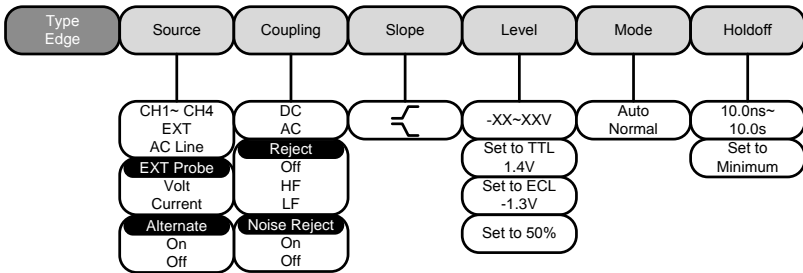

Trigger Delay Menu

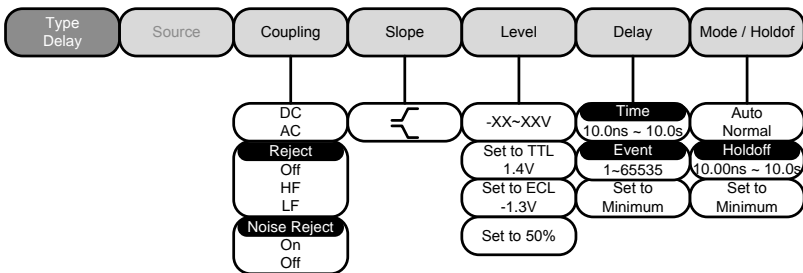

Trigger Pulse Width Menu

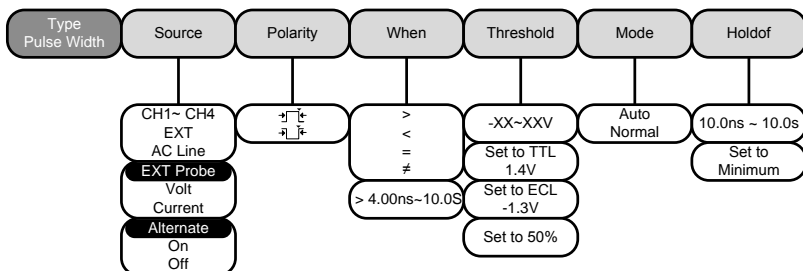

Trigger Video Menu

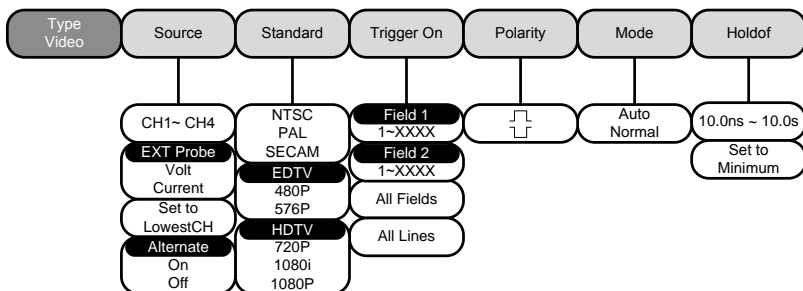

Trigger Pulse Runt Menu

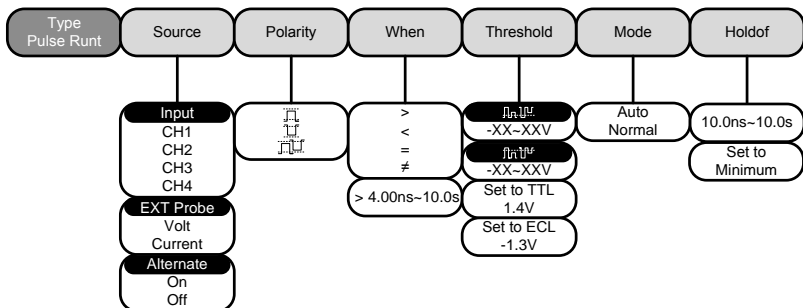

Trigger Rise & Fall Menu

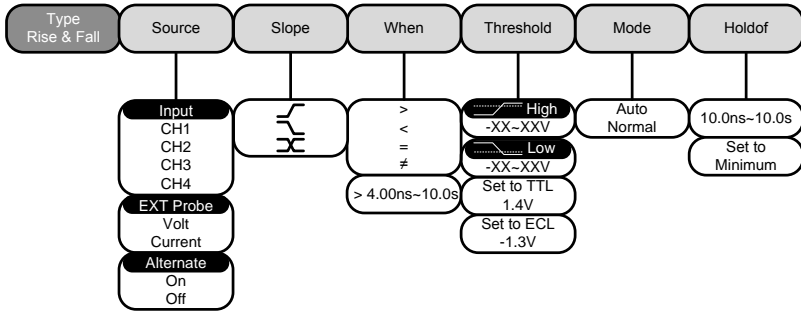

Utility Key

Utility

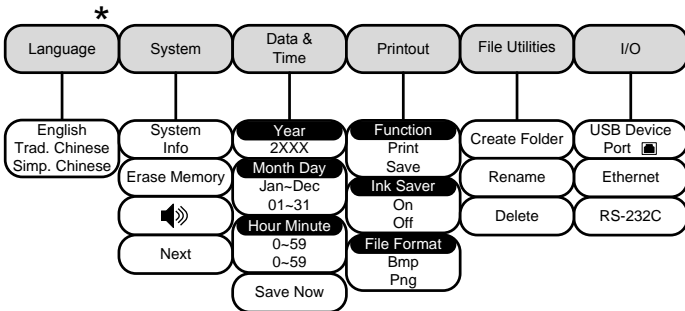

- Next → Goes to the System Self Cal menu
- USB Device Port → Goes to the I/O USB Device Port menu
- Ethernet → Goes to the I/O Ethernet menu
- RS-232C → Goes to the I/O RS232 menu
- Create Folder → Goes to the File Utilities
- Rename → Goes to the File Utilities

*Default languages only. See page 146 for details.

Utility Key – I/O

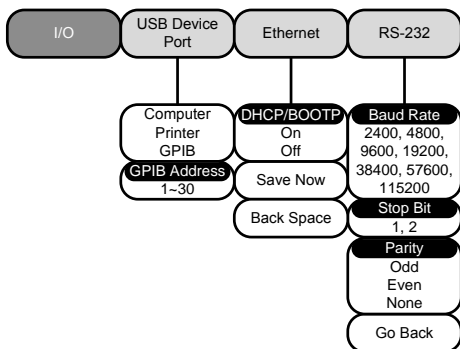

Utility Key – File Utilities

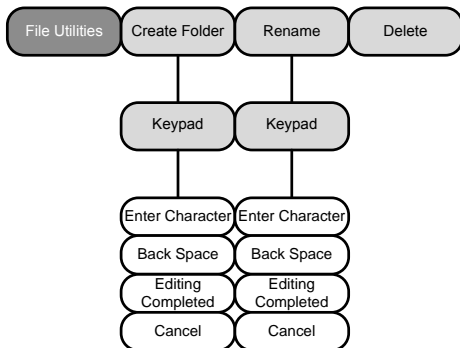

Utility Key – Self Calibration

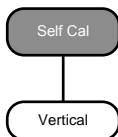

Zoom Key

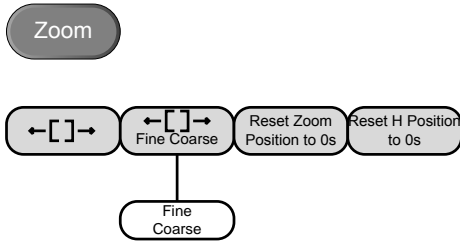

Default Settings

The default factory installed settings can be recalled at any time by pressing the *Default Setup* key.



Acquire	Mode: Sample	XY: OFF
	Interpolation: Sin(x)/x	Sample rate: 250MSPS
Display	Mode: Vector	Persistence: Auto
	Waveform intensity: 50%	Graticule intensity: 50%
	Waveform visuals: Gray	Graticule: full 
Channel	Scale: 100mV/Div	CH1: On
	Coupling: DC	Impedance: 1MΩ
	Invert: Off	Bandwidth: full
	Expand: By ground	Position: 0.00V
	Probe: voltage	Probe attenuation: 1x
	Deskew: 0s	
Cursor	Horizontal cursor: Off	Vertical Cursor: Off
Measure	Source: CH1	Gating: Off
	Display: Off	
Horizontal	Scale: 10us/Div	
Math	Source1: CH1	Operator: +
	Source2: CH2	Position: 0.00 Div
	Unit/Div: 200mV	Math Off
Test	App: Go-NoGo	
Trigger	Type: Edge	Source: CH1
	Coupling: DC	Alternate: Off
	Rejection: Off	Noise Rejection: Off

	Slope: positive	Level: 0.00V
	Mode: Auto	Holdoff: 10.0ns
Utility	Print key: Save	Ink Saver: Off
Save Recall	Image file format: Bmp	Data file format: LSF

Built-in Help

The Help key accesses a context sensitive help menu. The help menu contains information on how to use the front panel keys.

Panel Operation 1. Press the *Help* key. The display changes to Help mode.



2. Use the Variable knob to scroll up and down through the Help contents. Press *Select* to view the help on the selected item.

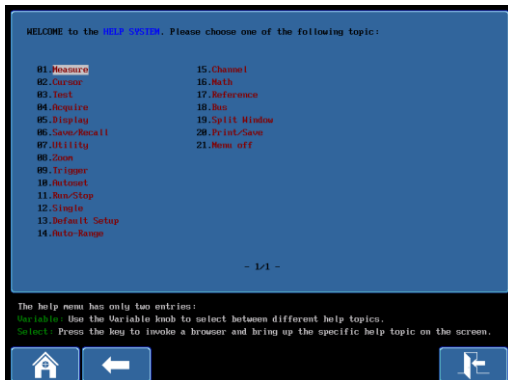

Home Key Press the *Home* key to return to the main help screen.



Go Back Press the *Back* key to go to the previous menu page.



Exit Press the *Help* key again or press the *Exit* key to exit the Help mode.

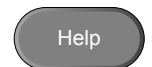

M EASUREMENT

Basic Measurement.....	63
Channel Activation.....	63
Autoset	64
Auto Range.....	65
Run/Stop	66
Horizontal Position/Scale	67
Vertical Position/Scale	69
Split Window Mode	70
Automatic Measurement.....	72
Measurement Items.....	72
Individual Mode	75
Remove Measurement.....	76
Gated mode.....	77
Display All mode.....	78
Cursor Measurement.....	80
Use Horizontal Cursors.....	80
Use Vertical Cursors	83
Math Operation	86
Overview.....	86
Addition/Subtraction/Multiplication	87
FFT	89
Applications.....	91
Overview.....	91
Running Applications	91
Using Go_NoGo	93

Power Analysis **98**
 Power Analysis Overview 98

Serial Bus **99**
 Serial Bus Overview 99

Basic Measurement

This section describes the basic operations required in capturing and viewing the input signal. For more detailed operations, see the following chapters.

- Cursor Measurement → from page 80
- Configuration → from page 91

Before operating the oscilloscope, please see the Getting Started chapter, page 13.

Channel Activation

Activate Channel

To activate an input channel, press a *channel* key.

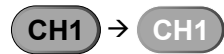

When activated, the channel key will light up. The corresponding channel menu will also appear.

Each channel is associated with the color shown beside the VOLTS/DIV dial: CH1: yellow, CH2: blue, CH3: pink and CH4: green.

When a channel is activated, it is shown above the bottom menu system.

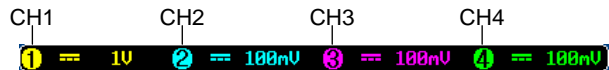

De-activate Channel

To de-activate a channel, press the corresponding *channel* key again. If the channel menu is not open, press the *channel* key twice (the first press shows the Channel menu).

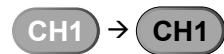

Default Setup To activate the default state, press *Default Setup*.



Autoset The *Autoset* key (page 64) does NOT automatically activate the channels to which input signals are connected.

Autoset

Background The Autoset function automatically configures the panel settings to position the input signal to the best viewing condition. The OSCILLOSCOPE automatically configures the following parameters.

- Horizontal scale
- Vertical scale
- Trigger source channel

Panel Operation 1. Connect the input signal to the OSCILLOSCOPE and press the *Autoset* key.



2. The waveform appears in the center of the display.

Before

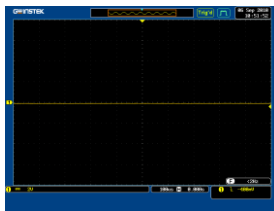

After

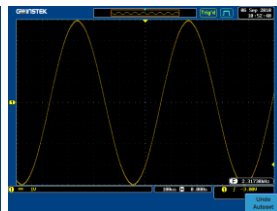

3. To undo Autoset, press *Undo Autoset* from the bottom menu. To remove the *Undo Autoset* softkey, press any other key.



-
-
- Limitation Autoset does not work in the following situation.
- Input signal frequency is less than 20Hz
 - Input signal amplitude is less than 30mV

Auto Range

Background The Auto Range function works similarly to the Autoset function, except the Auto Range function works continuously when it is on. The Auto Range function will continuously monitor the input signal and adjust the horizontal and vertical scale of a displayed signal so that waveform(s) are displayed at the best possible scale.

In addition, the Auto Range function can be also configured to only adjust the vertical or horizontal scale.

-
- Panel Operation** 1. After a signal has already been triggered, press the *Auto-Range* key. The *Auto-Range* key lights up.

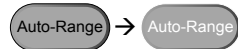

2. The waveform appears in the center of the display.

Before

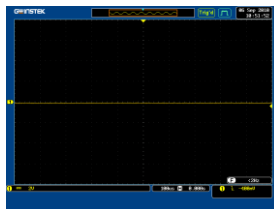

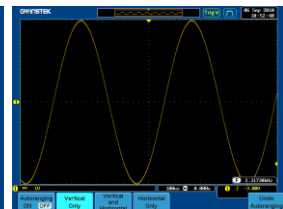

After

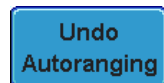

3. To undo Auto-Range, press *Undo Autoranging* from the bottom menu.

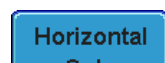
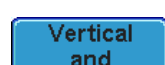

Disable Auto-Range	Press <i>Autoranging</i> from the bottom menu to turn Auto-Range On/Off.	
Configure Auto-Range	Press <i>Vertical Only</i> for vertical autoranging only.	
	Press <i>Horizontal Only</i> for horizontal autoranging only.	
	Press <i>Horizontal and Vertical</i> for autoranging on both axes.	

- Limitation
- Auto Range does not work in the following situation.
- Input signal frequency is less than 20Hz
 - Input signal amplitude is less than 30mV

Run/Stop

Background

By default, the waveform on the display is constantly updated (Run mode). Freezing the waveform by stopping signal acquisition (Stop mode) allows flexible observation and analysis. To enter Stop mode, two methods are available: pressing the Run/Stop key or using the Single Trigger mode.

Stop mode icon When in Stop mode, the Stop icon appears at the top of the display.



Triggered icon



Freeze
Waveform by
Run/Stop Key

Press the *Run/Stop* key once. The waveform and signal acquisition freezes. To unfreeze, press the *Run/Stop* key again.



Freeze
Waveform by
Single Trigger
Mode

In the Single Trigger mode, the waveform always stays in the Stop mode, and is updated only when the *Single* key is pressed. When the *single* key is pressed, the Run/Stop key turns red. For details, see page 129.

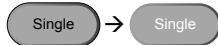

Waveform
Operation

The waveform can be moved or scaled in both Run and Stop mode, but in different manners. For details, see page 116 (Horizontal position/scale) and page 121 (Vertical position/scale).

Horizontal Position/Scale

For more detailed configuration, see page 116.

Set Horizontal
Position

The horizontal position knob moves the waveform left and right.



As the waveform moves, the memory bar on the top of the display indicates the portion of the waveform currently shown on the display and the position of the horizontal marker on the waveform.

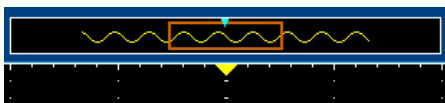

Position Indicator

The horizontal position is shown at the bottom of the display grid to the right of H icon.



Select Horizontal Scale

To select the timebase (scale), turn the *TIME/DIV* knob; left (slow) or right (fast).

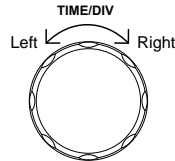

Range 1ns/div ~ 100s/div, 1-2-5 increments

The Time/Division rate is displayed to the left of the H icon at the bottom of the screen.



Memory bar The size of the memory bar changes to reflect the timebase and the section of waveform that is displayed on screen.

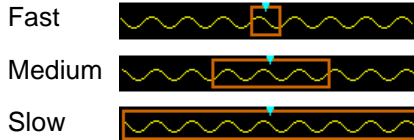

The Sample rate changes according to the time/division. See page 108.

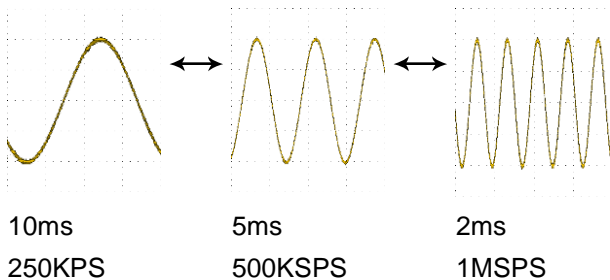

Stop mode In the Stop mode, the waveform size changes according to the scale.

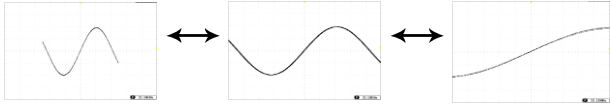

Vertical Position/Scale

For more detailed configuration, see page121.

Set Vertical Position

To move the waveform up or down, turn the *vertical position knob* for each channel.

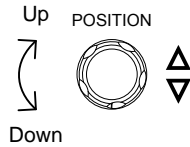

As the waveform moves, the vertical position of the cursor appears on the display.

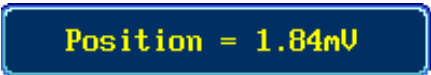

Run/Stop mode

The waveform can be moved vertically in both Run and Stop mode.

Select Vertical Scale

To change the vertical scale, turn the *VOLTS/DIV* knob; left (down) or right (up).

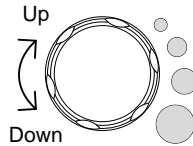

Range 2mV/div ~ 1V/div (50Ω/75Ω)/,
2mV/div ~ 5V/div (1MΩ)
1-2-5 increments



The vertical scale indicator for each channel on the bottom of the display changes accordingly.



Split Window Mode

The split window mode is able to display and trigger each active channel independently. The split window mode is especially useful for signal comparisons. Reference waveforms can also be used in this mode. Most functions and features can be used with split screen mode bar the Math, XY display and Zoom mode.

Enter Split
Screen Mode

1. Activate each channel that is to be used in the split screen mode.  →  page 63

2. Press the *Split Window* key to enter the split screen mode. 

3. Split window mode appears. The number of windows depends on the number of active channels. 1-2 active channels will produce 2 split windows, while 3-4 active channels will produce 4 split windows.

Example

4 channel split window

2 channel split window

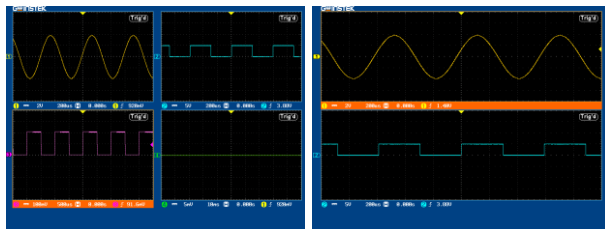

Select Active
Channel

The split window that has the active channel is shown with an orange border.

To select the active channel, press the corresponding split window key. In order from top-left, clockwise: CH1, CH2, CH3, CH4.

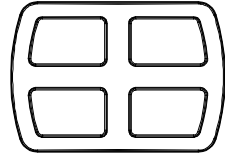

Example

CH4 Not active

CH4 Active

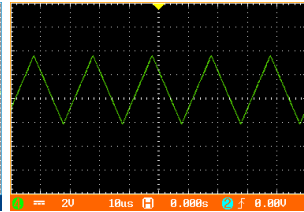
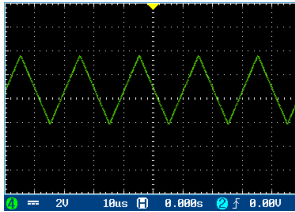

Reference Waveforms

Reference waveforms can also be used in this mode. Each reference waveform will be recalled to the corresponding split window number. I.e., Ref1 will be recalled to the first split window, Ref2 to the second window and so on.

Exit Split Window mode

























To exit split window mode, press the *Split Window* key again.











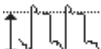

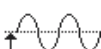
Automatic Measurement

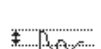

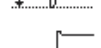
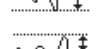



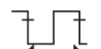
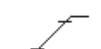
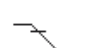
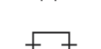
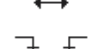

The automatic measurement function measures and updates major items for Voltage/Current, Time, and Delay type measurements.

Measurement Items

	V/I Measurements	Time Meas.	Delay Meas.
Overview	Pk-Pk	 Frequency	 FRR
	Max	 Period	 FRF
	Min	 RiseTime	 FFR
	Amplitude	 FallTime	 FFF
	High	 +Width	 LRR
	Low	 -Width	 LRF
	Average	 DutyCycle	 LFR
	RMS		 LFF
	ROVShoot		Phase
	FOVShoot		
	RPREShoot		
	FPREShoot		
Voltage/Current Measurement	Pk-Pk (peak to peak)	 Difference between positive and negative peak voltage (=Vmax - Vmin)	
	Max	 Positive peak voltage	
	Min	 Negative peak voltage	
	Amplitude	 Difference between global high and global low voltage (=Vhi - Vlo)	

High		Global high voltage
Low		Global low voltage
Average		Averaged voltage of the first cycle
RMS		RMS (root mean square) voltage
ROVShoot		Rise overshoot voltage
FOVShoot		Fall overshoot voltage
RPREShoot		Rise preshoot voltage
FPREShoot		Fall preshoot voltage

Time Measurement	Frequency		Frequency of the waveform
	Period		Waveform cycle time (=1/Freq)
	RiseTime		Rising time of the pulse (~90%)
	FallTime		Falling time of the pulse (~10%)
	+Width		Positive pulse width
	-Width		Negative pulse width
	Duty Cycle		Ratio of signal pulse compared with whole cycle =100x (Pulse Width/Cycle)

Delay Measurement	FRR		Time between: Source 1 first rising edge and Source 2 first rising edge
	FRF		Time between: Source 1 first rising edge and Source 2 first falling edge
	FFR		Time between: Source 1 first falling edge and Source 2 first rising edge
	FFF		Time between: Source 1 first falling edge and Source 2 first falling edge
	LRR		Time between: Source 1 first rising edge and Source 2 last rising edge
	LRF		Time between: Source 1 first rising edge and Source 2 last falling edge
	LFR		Time between: Source 1 first falling edge and Source 2 last rising edge
	LFF		Time between: Source 1 first falling edge and Source 2 last falling edge
	Phase		The phase difference of two signals, calculated in degrees. $T1 \div T2 \times 360$.

Individual Mode

Individual mode shows up to eight selected measurement items on bottom of the screen from any channel source.

Add Measurement Item

1. Press the *Measure* key.



2. Press *Add Measurement* from the bottom menu.



3. Choose either a *V/I*, *Time* or *Delay* measurement from the side menu.

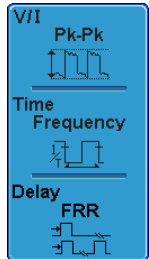

V/I (Voltage/Current) Pk-Pk, Max, Min, Amplitude, High, Low, Average, RMS, ROVShoot, FOVShoot, RPRESshoot, FPRESshoot

Time Frequency, Period, RiseTime, FallTime, +Width, -Width, Duty Cycle

Delay FRR, FRF, FFR, FFF, LRR, LRF, LFR, LFF, Phase

4. All individual measurements will be displayed in a window on the bottom of the screen. The channel number and channel color indicate the measurement source: yellow = CH1, blue = CH2, pink = CH3, green = CH4.



Choose a Source

The channel source for measurement items can be set either before or when selecting a measurement item.

- To set the source, press either the *Source1* or *Source2* key from the side menu and choose the source. Source 2 is only for delay measurements.

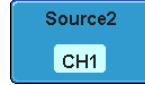
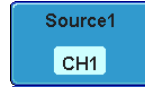

Range CH1, CH2, CH3, CH4

Split Window Mode

Individual mode can be used with the split window mode. Each individual measurement will be displayed in the split window that houses the source of the measurement.

Delay measurements are not supported as only one source can be used for each measurement in split window mode.

Remove Measurement

Individual measurements can be removed at any time using the Remove Measurement function.

Remove Measurement Item

- Press the *Measure* key.
- Press *Remove Measurement* from the bottom menu.
- Choose which measurement window (if in split window mode) the item is located in (*Window 1~4*) and use the variable knob to remove an item.

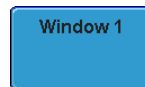
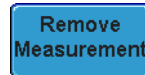

Remove All
Items

Press *Remove All* to remove all the measurement items in full screen mode, or to remove all the measurement items for the active window in split screen mode.



Gated mode

Some automatic measurements can be limited to a “gated” area between cursors. Gating is useful for measuring a magnified waveform or when using a fast time base. The Gated mode has three possible configurations: Off (Full Record), Screen and Between Cursors.

Set Gating Mode 1. Press the *Measure* key.



2. Press *Gating* from the bottom menu.

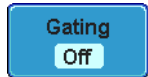

3. Choose one of the gating modes from the side menu: *Off (full record)*, *Screen*, *Between Cursors*



Cursors On
Screen

If *Between Cursors* is selected, the cursor positions can be edited by using the cursor menu.

Page 80

Display All mode

Display All mode shows and updates all items from Voltage and Time type measurements.

View Measurement Results

1. Press the *Measure* key.



2. Press *Display All* from the bottom menu.



3. Choose a channel (*CH1*, *CH2*, *CH3*, *CH4*) from the side menu to display auto measurement items.

Note: only the channels that are activated are available.

4. The results of Voltage and Time type measurements appear on the display.



Remove Measurements

To remove the measurement results, press *OFF*.



Delay
Measurements

Delay type measurement is not available in this mode as only one channel is used as the source. Use the Individual measurement mode (page 75) instead.

Cursor Measurement

Horizontal or vertical cursors are used to show the position and values of waveform measurements and math operation results. These results cover voltage, time, frequency and other math operations. When the cursors (horizontal, vertical or both) are activated, they will be shown on the main display unless turned off. (page 115).

Use Horizontal Cursors

Panel Operation/ 1. Press the *Cursor* key once.
Range

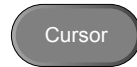

2. Press *H Cursor* from the bottom menu.



3. Press *H Cursor* repeatedly to toggle the cursor type.

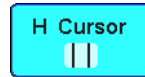

Range

- | | | |
|--|--|--------------------------------------------------|
| | | Left cursor movable, right cursor position fixed |
| | | Right cursor movable, left cursor position fixed |
| | | Left and right cursor movable together |

4. The cursor position information appears on the top left hand side of the screen

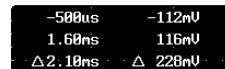

5. Use the *Variable knob* to move the movable cursor(s) left or right.

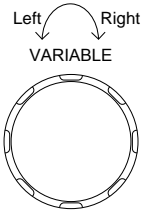

Cursors Time, Voltage/Current
 Δ Delta (difference between cursors)

Example

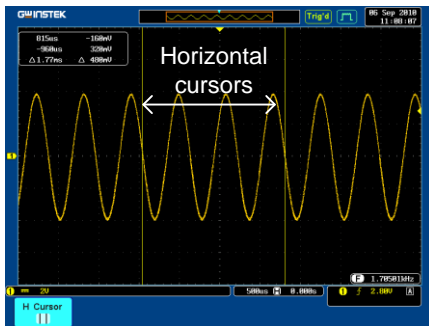

FFT Math

The FFT Math has different content. For FFT math details, see page 89.





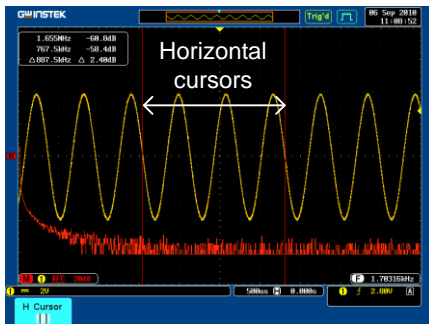

Cursors Frequency, dB/V
 Δ Delta (difference between cursors)

Example



XY Mode

XY mode cursors measure a number of X by Y measurements.

 (X) Versus (Y)	Cursor1	Cursor2	Δ
		t: -250.0us	250.0us
Rectangular 	x: -90.0mV y: -10.0mV	110mV 7.20mV	200mV 17.2mV
Polar 	r: 90.5mV θ : 6.34Deg	110mV 3.74Deg	19.6mV 2.59Deg
Product 	x*y: 900uV	792uV	108uV
Ratio y+x:	111mV	65.4mV	45.6mV

Cursors Time, rectangular, polar coordinates, products, ratio.

Δ Delta (difference between cursors)

Example

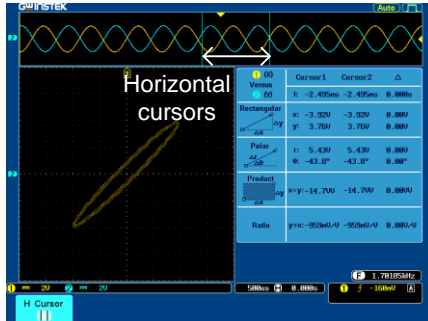

Use Vertical Cursors

Panel Operation/ Range 1. Press the *Cursor* key twice.



2. Press *V Cursor* from the bottom menu.

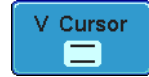

3. Press *V Cursor* repeatedly to toggle the cursor type.

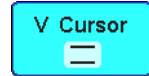

Range

----- Upper cursor movable, lower cursor position fixed

===== Lower cursor movable, upper cursor position fixed

===== Upper and lower cursor movable together

4. The cursor position information appears on the top left hand side of the screen.



5. Use the *Variable knob* to move the cursor(s) up or down.

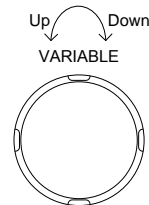

Cursors

□ ○ Time, Voltage/Current

△ Delta (difference between cursors)

Example

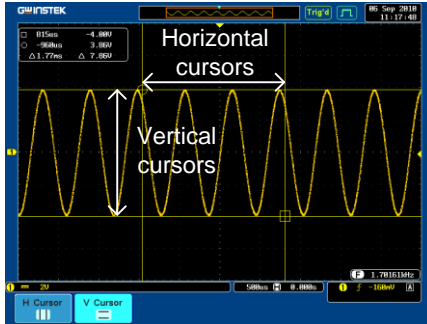

FFT Math

The FFT Math has different content. For FFT math details, see page 89.

□	1.490MHz	43.3dB
○	3.495MHz	-43.3dB
△	2.005MHz	86.6dB

Cursors



Frequency, dB/V



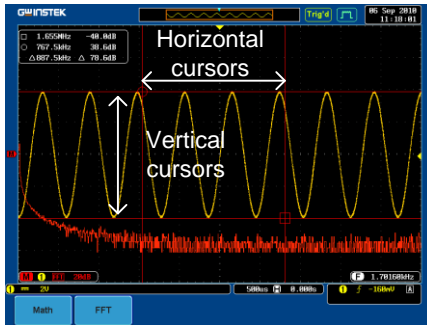

Delta (difference between cursors)

Example

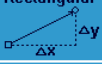
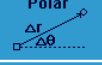
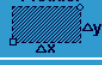

XY Mode

XY mode cursors measure a number of X by Y measurements.

 Versus t:	Cursor1	Cursor2	Δ
Rectangular 	x: 5.00nU	199nU	194nU
	y: 14.2nU	-12.2nU	26.4nU
Polar 	r: 15.8nU	199nU	184nU
	θ : 78.6Deg	-3.58Deg	74.1Deg
Product 	x*y: 71.8uU	-2.42nU	2.49nU
Ratio 	y/x: 2.84U/U	-61.3nU/U	2.98U/U

Cursors



Rectangular, polar co-ordinates, products, ratio.



Delta (difference between cursors)

Example

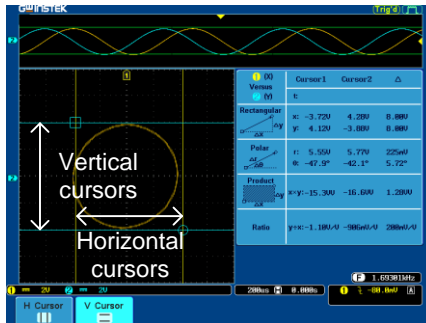

Math Operation

Overview

Background	Math operation runs addition, subtraction, multiplication, division or FFT using the input signals or reference waveforms (Ref1~4) and shows the result on the display. The resulted waveform characteristics can be measured using the cursors.	
Addition (+)	Adds the amplitude of two signals.	
	Source	CH1~4, Ref1~4
Subtraction (-)	Extracts the amplitude difference between two signals.	
	Source	CH1~4, Ref1~4
Multiplication (×)	Multiplies the amplitude of two signals.	
	Source	CH1~4, Ref1~4
Division (÷)	Divides the amplitude of two signals.	
	Source	CH1~4, Ref1~4
FFT	Runs FFT calculations on a signal. Four types of FFT windows are available: Hanning, Hamming, Rectangular, and Blackman.	
	Source	CH1~4, Ref1~4
Hanning FFT Window	Frequency resolution	Good
	Amplitude resolution	Not good
	Suitable for....	Frequency measurement on periodic waveforms

Hamming FFT Window	Frequency resolution	Good
	Amplitude resolution	Not good
	Suitable for....	Frequency measurement on periodic waveforms
Rectangular FFT Window	Frequency resolution	Very good
	Amplitude resolution	Bad
	Suitable for....	Single-shot phenomenon (this mode is the same as having no window at all)
Blackman FFT Window	Frequency resolution	Bad
	Amplitude resolution	Very good
	Suitable for....	Amplitude measurement on periodic waveforms

Addition/Subtraction/Multiplication

Panel Operation 1. Press the *Math* key.



2. Press the *Math* key on the lower bezel.

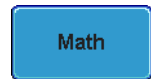

3. Select *Source 1* from the side menu

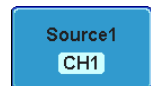

Range CH1~4, Ref~4

4. Press *Operator* to choose the math operation.

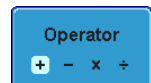

Range +, -, x, ÷

5. Select *Source 2* from the side menu.



Range CH1~4, Ref~4

6. The math measurement result appears on the display. The vertical scale of the math waveform appears at the bottom of the screen.



From left: Math function, source1, operator, source2, Unit/div

Example

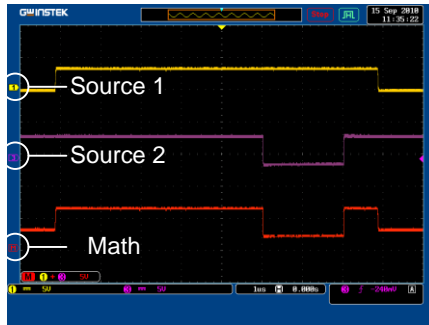

Position and Unit

To move the math waveform vertically, press the *Position* key from the side menu and use the variable knob to set the position.



To change the unit/div settings, press *Unit/div*, then use the variable knob change the unit/div.

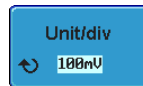

Range 2mV~1kV

Turn Off Math

To turn off the Math result from the display, press the *Math* key again.



FFT

Panel Operation 1. Press the *Math* key.



2. Press *FFT* from the bottom menu.



3. Select the *Source* from the side menu.



Range CH1~4, Ref~4

4. Press the *Vertical Units* key from the side menu to select the vertical units used.



Range Linear RMS, dBV RMS

5. Press the *Window* key from the side menu and select the window type.



Range Hanning, Hamming, Rectangular, and Blackman.

6. The FFT result appears. For FFT, the horizontal scale changes from time to frequency, and the vertical scale from voltage/current to dB/RMS.

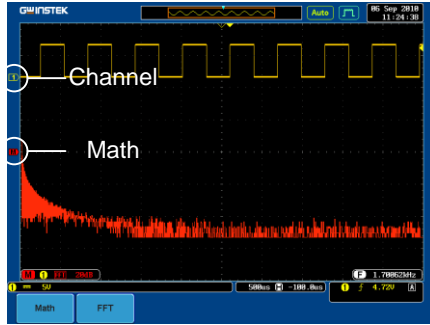

Position and Unit

To move the FFT waveform vertically, press *Position* and use the variable knob.

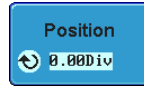

Range -12.00 Div ~ +12.00 Div

To select the vertical scale of FFT waveform, press *Unit/div* and use the variable knob.

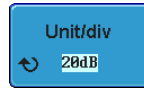

Range 2mV~1kV RMS, 1~20 dB

Clear FFT

To clear the FFT result from the display, press the *Math* key again.



Applications

Overview

Background	The APP. function allows different applications to be run.
------------	------------------------------------------------------------

Applications	GO-NOGO	The GO_NOGO application can be used to set threshold boundaries for input signals. GO-NOGO checks if a waveform fits inside a user-specified maximum and minimum amplitude boundary (template).
--------------	---------	-------------------------------------------------------------------------------------------------------------------------------------------------------------------------------------------------

Running Applications

Background	The APP. function can host a number of different applications that can be downloaded
------------	--------------------------------------------------------------------------------------

Panel Operation 1. Press the *Test* key.

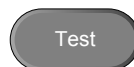

2. Press *APP.* from the bottom menu.



3. Scroll through each Application using the Variable knob.



4. Select an application by pressing the *Select* key *twice*.



×2

Using Go_NoGo

Background The Go-NoGo test checks if a waveform fits inside a user-specified maximum and minimum boundary (boundary template). Boundary templates are automatically created from a source channel. Boundary tolerance and violation conditions can be set.

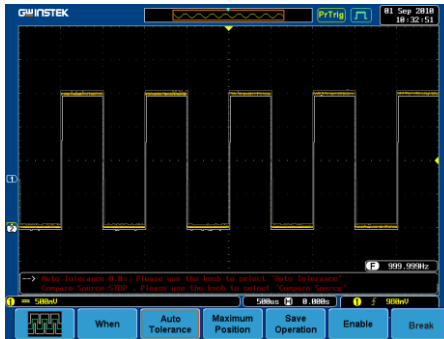

Choose the Go_NoGo application from the APP. menu. See page 91.

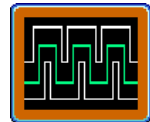

Go-NoGo Conditions Select the Go-NoGo conditions (When) and actions when a Go-NoGo condition has been met (Violating).

1. Press *When* from the bottom menu and use the Variable knob to select the *When* condition.



When Exit: Sets the NoGo condition to when the input signal exceeds the limit boundary.

Enter: Sets the NoGo condition to when the input signal stays within the limit boundary.

2. Press *When* again to change the menu to *Violating*. Use the Variable knob to choose the action for when a violation occurs.

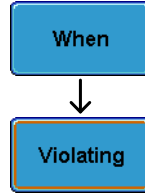

Violating Stop: The waveform will be frozen.

Stop_Beep: The waveform will be frozen and a beep will be output.

Continue: Ignore the violation.

Continue_Beep: Output a beep, but continue to monitor the signal.

Source

1. Press *Compare Source* from the bottom menu and use the Variable knob to select the source.



Source CH1, CH2, CH3, CH4

Tolerance Boundary

1. To set a tolerance, press *Compare Source* again to toggle the menu to *Auto Tolerance*. Use the Variable knob to choose the tolerance as a percentage.

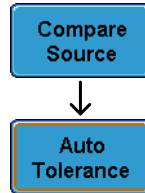

Violating 0.4% ~ 40% (.4% steps)

Note If a tolerance is set, the maximum and minimum boundary is reset as the tolerance boundary.

Maximum and Minimum

1. To set a maximum and minimum boundary, press *Minimum Position* from the bottom menu and use the Variable knob to select the absolute minimum position.



Position Voltage division range

2. Press *Minimum Position* again to toggle the menu to Maximum Position. Choose the maximum position.

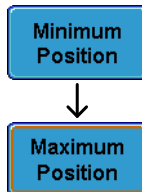

Position Voltage division range

Note If a maximum and minimum boundary is set, the tolerance will be disabled.

Save Boundary Limits

1. Select a *Maximum Position* or a *Tolerance* from the lower menu.
2. To save the Go-NoGo test parameters, press *Save Operation*. The Maximum position will be saved to R1. The tolerance waveforms will be saved to R1 and R2.
3. If a *Maximum Position* was saved, repeat the save procedure for *Minimum Position*. The Minimum position waveform will be saved to R2.

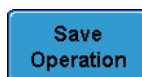

Start Go-NoGo Press *Enable* to start the Go-NoGo test. The Enable button will change to Disable. Pressing *Disable* will stop the Go-NoGo test and toggle the button back to Enable.

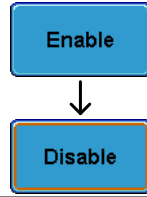

Exit the Application To exit the application, press *Break*.



Using the Go-NoGo Output

To output the Go-NoGo results to an external device, the Go-NoGo rear panel terminal (open collector) can be used. The Go-NoGo terminal will output a positive pulse each time a NoGo violation has occurred for a minimum of 10us. The voltage of the pulse depends on the external pull-up voltage.

Go / No Go (Open collector)

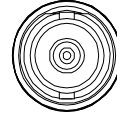

The line out socket can also be used to connect directly to a buzzer.

Line Out



Timing Diagram

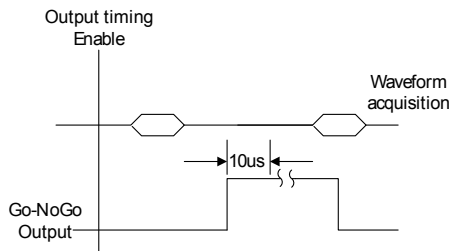

When a No-Go violation occurs the Go-NoGo output will go from a low level to a high level for a minimum of 10us.

Circuit Diagram

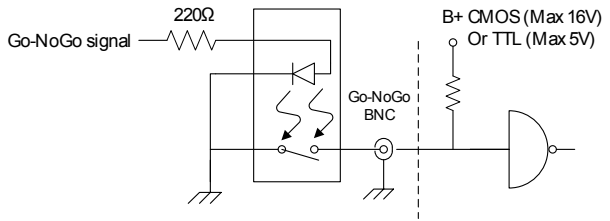

Power Analysis

Power analysis provides automatic measurement for a number of advanced measurement types such as power quality, harmonics, ripple and inrush current. The Power analysis software is an optional software module, for details please see page 197. Please see the Power Analysis manual for more details on using the power analysis software.

Power Analysis Overview

Power Quality	Power quality measures the power of a signal using the measured voltage and current of a signal.
Harmonics	The harmonics function shows signal harmonics up to the 400th harmonic. Harmonic tests can be user defined and common harmonic standards such as IEC 61000-3-2 can also be tested for.
Ripple	The ripple function calculates the ripple and noise of the waveform.
Inrush Current	The inrush function automatically calculates the first peak and second peak inrush current.

Serial Bus

The serial bus trigger and decode software includes support for 3 common serial interfaces, SPI (4 channel models only), UART and I²C. Each interface is fully configurable to accommodate a wide range of protocol variation.

Each input can be displayed as binary or hexadecimal. An event table can also be created to aid in debugging.

Note that the Serial bus trigger and decode software is an optional extra. An activation key is required to activate the software, for details please see page 197. Please see the Serial Bus Decode manual for more details on using the serial bus software.

Serial Bus Overview

UART	Universal Asynchronous Receiver Transmitter. The UART bus is able to accommodate a wide range of various common UART serial communications. The UART serial bus software is suitable for a number of RS-232 protocol variants.
Inputs	Tx, Rx
Threshold	Tx, Rx
Configuration	Baud rate, Parity, Packets, End of packets, Input polarity
Trigger On	Tx Start Bit, Rx Start Bit, Tx End of Packet, Rx End of Packet, Tx Data, Rx Data, Tx Parity Error, Rx Parity Error
I ² C	Inter Integrated Circuit is a two line serial data interface with a serial data line (SDA) and serial clock line (SCLK). The R/W bit can be configured.
Inputs	SCLK, SDA

Threshold	SCLK, SDA
Configuration	Addressing mode, Read/Write in address
Trigger On	Start, Repeat Start, Stop, Missing Ack, Address, Data, Address/Data

SPI

The SPI (Serial Interface Peripheral) bus is fully configurable to accommodate the wide variety of SPI interfaces. This bus is only available on 4 channel models.

Inputs	SCLK, SS, MOSI, MISO
Threshold	SCLK, SS, MOSI, MISO
Configuration	SCLK edge, SS logic level, Word size, Bit order
Trigger On	SS Active, MOSI, MISO, MOSI&MISO

C ONFIGURATION

Acquisition	103
Select Acquisition Mode.....	103
Show Waveform in XY Mode	105
Set the Sampling Mode.....	107
Real time vs Equivalent Time Sampling Mode	108
Display.....	110
Display Waveform as Dots or Vectors	110
Set the Level of Persistence	111
Set the Intensity Level	111
Set the Waveform Intensity Type.....	113
Select Display Graticule	114
Freeze the Waveform (Run/Stop)	115
Turn Off Menu.....	115
Horizontal View	116
Move Waveform Position Horizontally	116
Select Horizontal Scale	117
Select Waveform Update Mode.....	118
Zoom Waveform Horizontally	119
Vertical View (Channel).....	121
Move Waveform Position Vertically.....	121
Select Vertical Scale.....	121
Select Coupling Mode.....	122
Set the Impedance.....	123
Invert Waveform Vertically	123
Limit Bandwidth.....	124
Expand by Ground/Center.....	125
Select Probe Type.....	126

Select Probe Attenuation Level.....	126
Set the Deskew.....	127
Trigger.....	129
Trigger Type Overview	129
Trigger Parameter Overview	131
Setup Holdoff Level.....	135
Setup Trigger Mode	136
Using the Edge Trigger	136
Using Advanced Delay Trigger.....	138
Using Pulse Width Trigger.....	139
Using Video Trigger.....	141
Pulse Runt trigger	142
Using Rise and Fall Trigger.....	144
System Info / Language / Clock.....	146
Select Menu Language	146
View System Information	146
Erase Memory	147
Set the Buzzer Volume	148
Set Date and Time.....	148

Acquisition

The Acquisition process samples the analog input signals and converts them into digital format for internal processing.

Select Acquisition Mode

Background	The acquisition mode determines how the samples are used to reconstruct a waveform.
Sample	This is the default acquisition mode. Every sample from each acquisition is used.
Peak detect	Only the minimum and maximum value pairs for each acquisition interval (bucket) are used. This mode is useful for catching abnormal glitches in the signal.
Hi Resolution	Averages the samples from each acquisition interval (bucket). The number of samples used for each bucket varies, depending on the sampling rate.
Average	Multiple acquired data is averaged. This mode is useful for drawing a noise-free waveform. To select the average number, use the Variable knob. Average number: 2, 4, 8, 16, 32, 64, 128, 256

Panel Operation 1. Press the *Acquire* key.



- To set the Acquisition mode, press *Mode* on the bottom menu.



- Select an acquisition mode from the side menu.

Mode	Sample, Peak Detect, Hi Resolution, Average
Average sample	2, 4, 8, 16, 32, 64, 128, 256



Example

Sample

Peak Detect

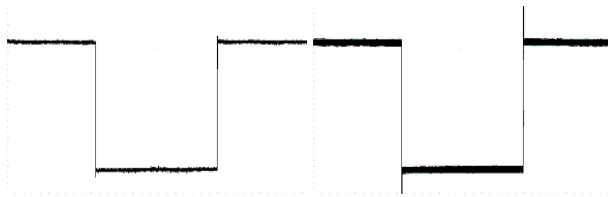

High Resolution

Average (256 times)

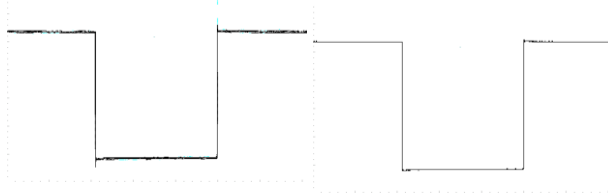

Show Waveform in XY Mode

Background The XY mode maps the voltage of channel 1 to the voltage of channel 2. In 4 channel models, the voltage of channel 3 is mapped to the voltage of channel 4. This mode is useful for observing the phase relationship between waveforms.

Reference waveforms can also be used in XY mode. Ref1 is mapped to Ref2 and Ref3 is mapped to Ref4. Using the reference waveforms is the same as using the channel input waveforms.

Connection

1. Connect the signals to Channel 1 (X-axis) and Channel 2 (Y-axis) or Channel 3 (X2-axis) and Channel 4 (Y2-axis).

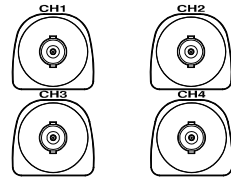

2. Make sure a channel pair is active (CH1&CH2 or CH3&CH4). Press the Channel key if necessary. A channel is active if the channel key is lit.



-
- Panel Operation** 1. Press the *Acquire* menu key.



2. Press XY from the bottom menu.



3. Choose *Triggered XY* from the side menu.



X-Y mode is split into two windows. The top window shows the signals over the full time range. The bottom window shows XY mode.

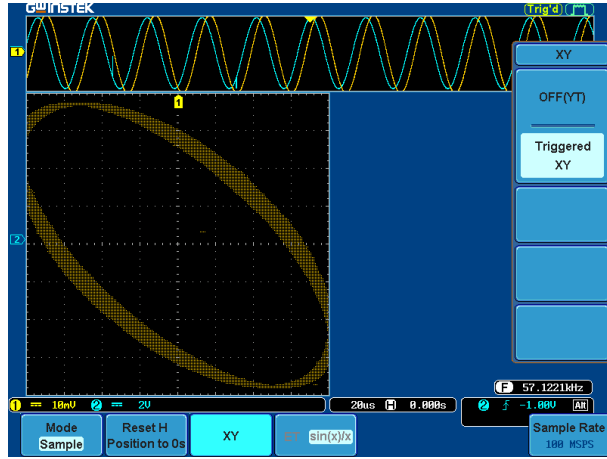

To move the X Y waveform position, use the vertical position knob: Channel 1 knob moves the X Y waveform horizontally, Channel 2 knob moves the X Y waveform vertically. Similarly, the X2 and Y2 axis can be positioned using the channel 3 and channel 4 vertical position knobs.

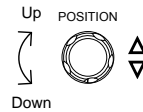

The horizontal position knob and Time/Div knob can still be used under the XY mode.

Turn Off XY Mode

To turn off XY mode, choose *OFF (YT)* mode.

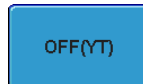

XY Mode

Cursors can be used with XY mode. See the Cursor chapter for details.

Page 80

Set the Sampling Mode

Background The OSCILLOSCOPE has two types of sampling modes: ET (Equivalent Time) and $\text{Sin}(x)/x$ interpolation. Equivalent time sampling is able to achieve a sample rate of 100GSa/s when sampling periodic waveforms. $\text{Sin}(x)/x$ interpolation uses a sinc interpolation formula to reconstruct a continuous signal between sampled points.

Panel Operation 1. Press the *Acquire* key.



2. Press the *ET/sin(x)/x* key on the bottom menu to toggle between equivalent time sampling (ET) and $\text{sin}(x)/x$ interpolation.

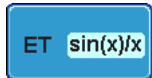

The sampling rate will be shown on the bottom right-hand corner

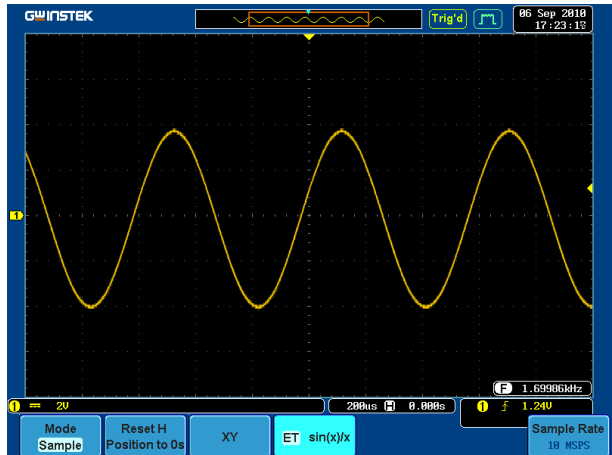

Real time vs Equivalent Time Sampling Mode

Background The sampling mode on the OSCILLOSCOPE can be switched between two sampling modes: Real-time and Equivalent-time. The number of active channels in operation will determine the sampling rate of the DSO. The sampling rate and mode depends on the number of active channels and whether the oscilloscope model has 2 or 4 channels.

Parameter	Real-time sampling	One sample of data is used to reconstruct a single waveform. Real-time sampling is used when the time base is relatively slow or if single shot events need to be captured.
	Equivalent-time sampling	Sampled data is accumulated a number of times to reconstruct a single waveform. This increases the sampling rate, but can only be used for repetitive signals. This mode is usually used when the time base is too fast for real-time sampling.

Real-time Vs. Equivalent-time

Sampling rate by number of active channels

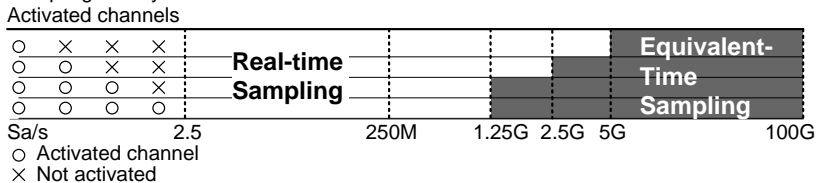

Single channel sampling rate for 2 channel models

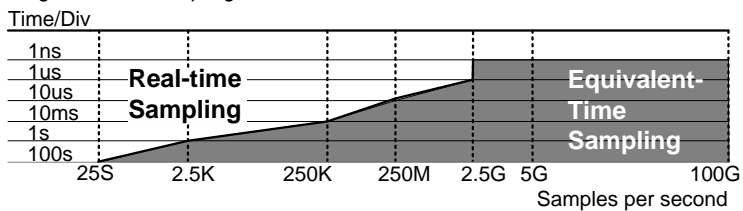

Single channel sampling rate for 4 channel models

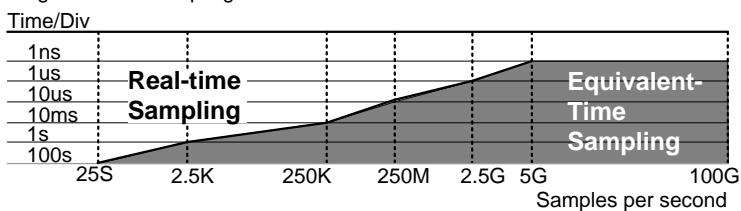

Display

The Display menu defines how the waveforms and parameters appear on the main LCD display.

Display Waveform as Dots or Vectors

Background When the waveform is displayed on screen, it can be displayed as dots or vectors.

Panel Operation 1. Press the *Display* menu key.



2. Press *Dot Vector* to toggle between Dot and Vector mode.



Range **Dots** Only the sampled dots are displayed.

Vectors Both the sampled dots and the connecting line are displayed.

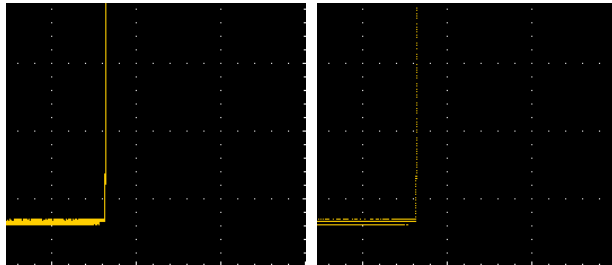

Example: **Vectors (square wave)** **Dots (square wave)**



Set the Level of Persistence

Background The persistence function allows the OSCILLOSCOPE to mimic the trace of a traditional analog oscilloscope. A waveform trace can be configured to “persist” for designated amount of time.

Panel Operation

1. Press the *Display* menu key. 
2. To set the persistence time, press the *Persistence* menu button on the bottom bezel. 
3. Use the variable knob to select a persistence time. 

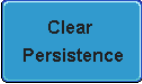

Time Auto, 100ms~10s, Infinite

Clear To clear persistence, press *Clear Persistence*. 

Set the Intensity Level

Background The intensity level of a signal can also be set to mimic the intensity of an analog oscilloscope by setting the digital intensity level.

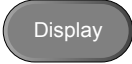
Panel Operation

1. Press the *Display* menu key. 
2. Press *Intensity* from the bottom menu. 

Waveform Intensity 3. To set the waveform intensity, press *Waveform Intensity* and edit the intensity.

Range 0~100%

Graticule Intensity 4. To set the graticule intensity, press *Graticule Intensity* from the side menu and edit the intensity value.

Range 10~100%

Example

Waveform Intensity 0%

Waveform Intensity 100%

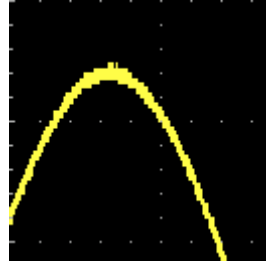
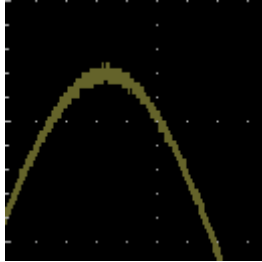

Graticule Intensity 10%

Graticule Intensity 100%

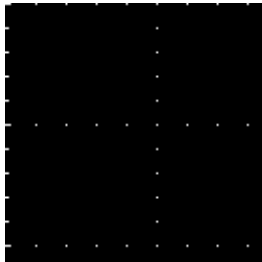

Set the Waveform Intensity Type

Background The intensity gradient of a signal can be set to grayscale or color. If intensity is set to color, the intensity gradient is analogous to a thermal color gradient where high intensity areas are colored red and low intensity areas are colored blue.

Panel Operation 1. Press the *Display* menu key.



2. Press *Waveform* from the bottom menu to toggle the intensity type.



Range Gray, Color

Example

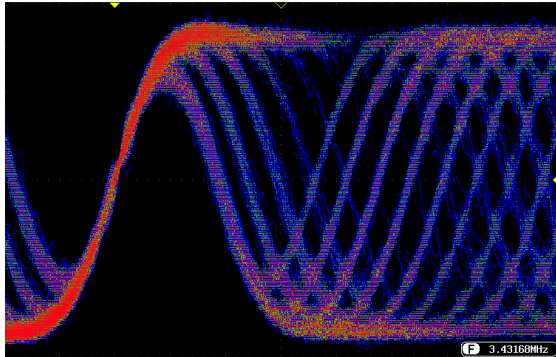

Select Display Graticule

Panel Operation 1. Press the *Display* menu key.

A grey, rounded rectangular button with the word "Display" in white text.

2. Press *Graticule* from the bottom menu.

A blue rectangular button with rounded corners and a thin black border, containing the word "Graticule" in white text.

3. From the side menu choose the graticule display type.



Full: Shows the full grid; X and Y axis for each division.



Grid: Show the full grid without the X and Y axis.



Cross Hair: Shows only the center X and Y frame.



Frame: Shows only the outer frame.

Freeze the Waveform (Run/Stop)

For more details about Run/Stop mode, see page 65.

- Panel Operation
1. Press the *Run/Stop* key. To unfreeze the waveform, press the *Run/Stop* key again.
 2. The waveform and the trigger freezes. The trigger indicator on the top right of the display shows Stop.

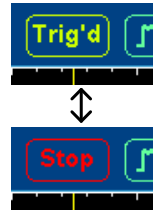

Turn Off Menu

- Panel Operation
1. Press the *Menu Off* key below the side menu keys to reduce a menu. The menu key needs to be pressed each time to reduce one menu.

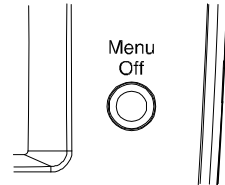

See page 37 for more information.

Horizontal View

This section describes how to set the horizontal scale, position, and waveform display mode.

Move Waveform Position Horizontally

Panel Operation The horizontal position knob moves the waveform left/right.

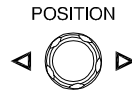

As the waveform moves, a position indicator on the top of the display indicates the horizontal position of the waveform in memory.

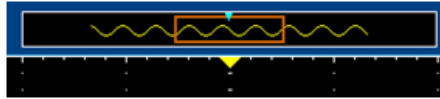

Reset Horizontal Position 1. To reset the horizontal position, press the Acquire key and then press *Reset H Position to 0s* from the bottom menu.

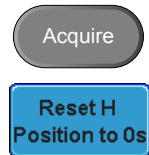

Run Mode In Run mode, the memory bar keeps its relative position in the memory since the entire memory is continuously captured and updated.

Select Horizontal Scale

Select Horizontal Scale To select the timebase (scale), turn the TIME/DIV knob; left (slow) or right (fast).

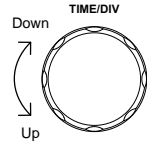

Range 1ns/div ~ 100s/div, 1-2-5 increment

The timebase indicator updates as the TIME/DIV is adjusted.

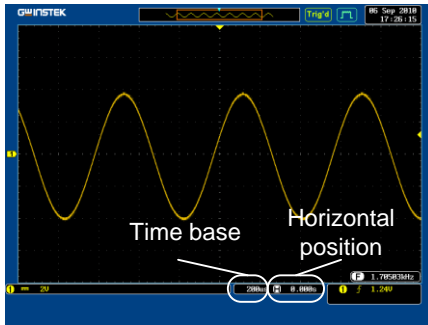

Run Mode In Run mode, the memory bar and waveform size keep their proportion. When the time base becomes slower, roll mode is activated (if trigger is set to Auto).

Stop Mode In Stop mode, the waveform size changes according to the scale.

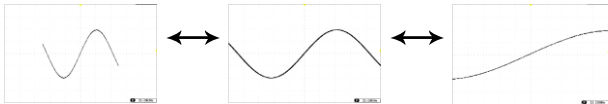

Select Waveform Update Mode

Background	The display update mode is switched automatically or manually according to the timebase and trigger.	
Normal	Updates the whole displayed waveform at once. Automatically selected when the timebase (sampling rate) is fast.	
	Timebase	$\leq 50\text{ms/div}$ ($\geq 500\text{Sa/s}$)
	Trigger	all modes
Roll Mode	<div style="display: inline-block; border: 1px solid black; background-color: #004a99; color: white; padding: 2px 5px; border-radius: 5px; margin-right: 5px;">Roll</div> Updates and moves the waveform gradually from the right side of the display to the left. Automatically selected when the timebase (sampling rate) is slow.	
	Timebase	$\geq 100\text{ms/div}$ ($\leq 25\text{MSPS}$)
	Trigger	all modes

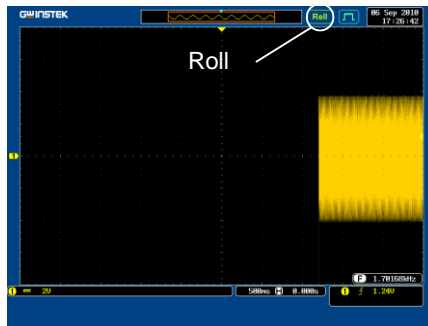

Select Roll Mode Manually

1. Press the *Trigger Menu* key.
2. Press *Mode* from the bottom menu and select *Auto (Untriggered Roll)* from the side menu.



Zoom Waveform Horizontally

Background When in Zoom mode the screen is split into 2 sections. The top of the display shows the full record length, with the bottom of the screen showing the normal view.

Panel Operation 1. Press the *Zoom* key.

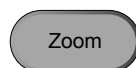

2. The Zoom mode screen appears.

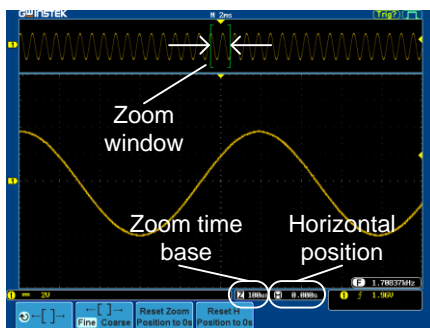

Horizontal Navigation

To scroll the waveform left or right, use the *Horizontal Position* knob.



To reset the horizontal position, press *Reset H Position to 0s*.



Zoom

To increase the zoom range, use the *TIME/DIV* knob.

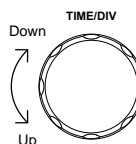

The zoom time base (Z) at the bottom of the screen will change accordingly.



Move the Zoom Window

Use the *Variable* knob to pan the zoom window horizontally.

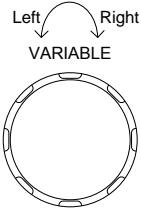

To reset the Zoom position, press *Reset Zoom Position to 0s*.



Scroll Sensitivity

To alter the scrolling sensitivity of the Zoom Window, press the $\leftarrow[\]\rightarrow$ key to toggle the scrolling sensitivity.

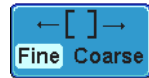

Sensitivity Fine, Coarse

Exit

To go back to the original view, press the *Zoom* key again.



Vertical View (Channel)

This section describes how to set the vertical scale, position, and coupling mode.

Move Waveform Position Vertically

Panel Operation

1. To move the waveform up or down, turn the *vertical position* knob for each channel.

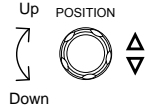

2. As the waveform moves, the vertical position of the cursor appears at the bottom half of the display.

Position = 0.00V

View or Reset Vertical Position

1. Press a channel key. The vertical position is shown in the \updownarrow Position / \downarrow Set to 0 soft key.
2. To change the position, press \updownarrow Position / \downarrow Set to 0 to reset the vertical position or turn the *vertical position* knob to the desired level.



Run/Stop Mode

The waveform can be moved vertically in both Run and Stop mode.

Select Vertical Scale

Panel Operation To change the vertical scale, turn the VOLTS/DIV knob; left (down) or right (up).



The vertical scale indicator on the bottom left of the display changes accordingly for the specific channel.

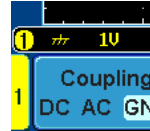

Range 2mV/div ~ 1V/div (50Ω/75Ω),
2mV/div ~ 5V/div (1MΩ). 1-2-5 increments

Stop Mode In Stop mode, the vertical scale setting can be changed.

Select Coupling Mode

Panel Operation 1. Press a *channel* key.



2. Press *Coupling* repeatedly to toggle the coupling mode for the chosen channel.



Range

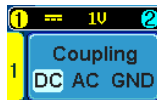

DC coupling mode. The whole portion (AC and DC) of the signal appears on the display.

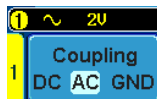

AC coupling mode. Only the AC portion of the signal appears on the display. This mode is useful for observing AC waveforms mixed with DC signals. AC coupling is not available with input impedances of 75Ω or 50Ω.

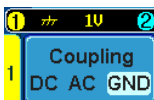

Ground coupling mode. The display shows only the zero voltage level as a horizontal line.

Example

Observing the AC portion of the waveform using AC coupling

DC coupling

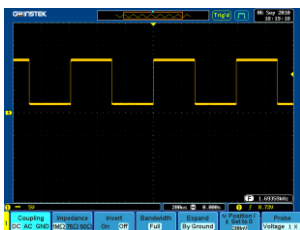

AC coupling

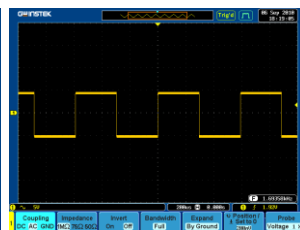

Set the Impedance

Panel Operation 1. Press the *Channel* key.



2. Press *Impedance* repeatedly to toggle between the impedance settings.

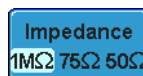

Impedance 1M Ω , 75 Ω , 50 Ω

Invert Waveform Vertically

Panel Operation 1. Press the *Channel* key.



2. Repeatedly press *Invert* to toggle Invert On or Off.

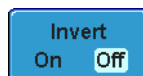

Limit Bandwidth

Background Bandwidth limitation puts the input signal into a selected bandwidth filter.

This function is useful for cutting out high frequency noise to see a clear waveform shape.

The bandwidth filters available are dependent on the bandwidth of the oscilloscope model.

Panel Operation 1. Press the *Channel* key.



2. Press *Bandwidth* from the bottom menu.



3. Choose a bandwidth* from the side menu (depending on the bandwidth of the oscilloscope).

Range 150MHz models: Full, 20MHz
 250MHz models: Full, 20MHz, 100MHz
 350MHz models: Full, 20MHz, 100MHz, 200MHz

Note When the input impedance is set to 75Ω , the bandwidth is limited to a maximum of 150MHz.

Example

BW Full

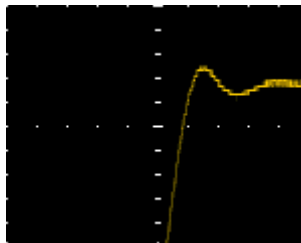

BW Limit 20MHz

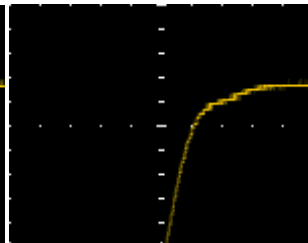

Expand by Ground/Center

Background When the voltage scale is changed, the Expand function designates whether the signal expands from the center of the signal or from the signal ground level. Expand by center can be used to easily see if a signal has a voltage bias. Expand by ground is the default setting.

Panel Operation 1. Press a *channel* key.



2. Press *Expand* repeatedly to toggle between expand *By Ground* and *Center*.



Range By Ground, By Center

Example If the vertical scale is changed when the Expand function is set to ground, the signal will expand from the ground level*. The ground level does not change when the vertical scale is changed.

If the vertical scale is changed when the Expand function is set to center, the signal will expand from the center of the signal. The ground level will suit to match the signal position.

*Or from the upper or lower edge of the screen if the ground level is off screen.

Expand by Ground

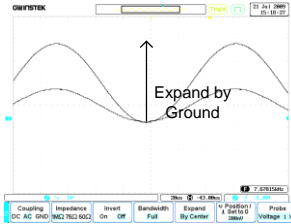

Expand by Center

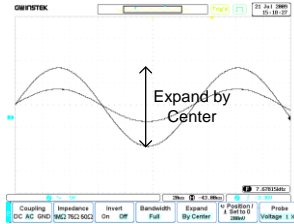

Select Probe Type

Background A signal probe can be set to voltage or current.

Panel Operation 1. Press the *Channel* key.



2. Press *Probe* from the bottom menu.



3. Press the *Voltage/Current* softkey to toggle between voltage and current.



Select Probe Attenuation Level

Background A signal probe has an attenuation switch to lower the original DUT signal level to the oscilloscope input range, if necessary. The probe attenuation selection adjusts the vertical scale so that the voltage level on the display reflects the real value on a DUT.

Panel Operation 1. Press the *Channel* key.



-
2. Press *Probe* from the bottom menu.



3. Press *Attenuation* on the side menu and use the variable knob to set the attenuation.

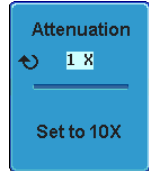

Alternatively, press *Set to 10X*.

Range 1mX ~1kX (1-2-5 step)

Note The attenuation factor adds no influence on the real signal. It just changes the voltage/current scale on the display.

Set the Deskew

Background The deskew function is used to compensate for the propagation delay between the oscilloscope and the probe.

- Panel Operation** 1. Press one of the *Channel* keys.



2. Press *Probe* from the bottom menu.

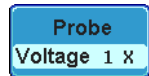

3. Press *Deskew* on the side menu and use the variable knob to set the deskew time.



Alternatively, press *Set to 0s* to reset the deskew time.

Range -50ns~50ns, 10ps increments

4. Repeat the procedure for another channel if necessary.

Trigger

The trigger configures the conditions for when the OSCILLOSCOPE captures a waveform.

Trigger Type Overview

Edge

The edge trigger is the simplest trigger type. An edge trigger triggers when the signal crosses an amplitude threshold with either a positive or negative slope.

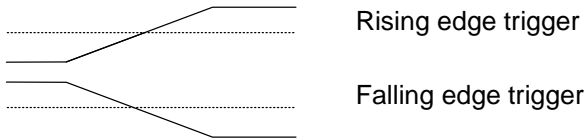

Delay

The Delay trigger works in tandem with the edge trigger, by waiting for a specified time or number of events before the edge trigger starts. This method allows pinpointing a location in a long series of trigger events.

Note: when using the delay trigger, the edge trigger source can be any one of the channel inputs, the EXT input or the AC line.

Delay trigger example (by event)

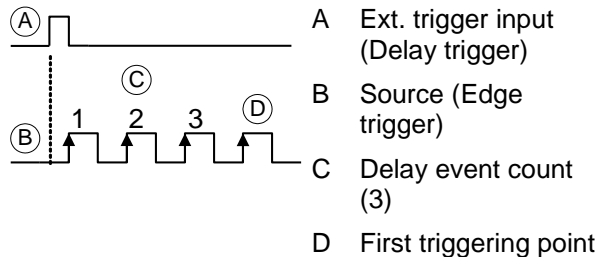

Delay trigger example (by time)

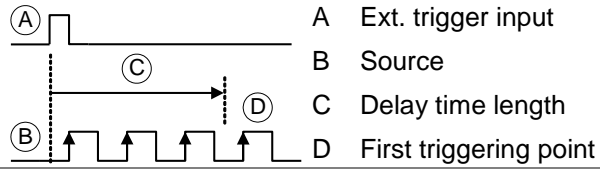

Pulse Width

Triggers when the pulse width of the signal is less than, equal, not equal or greater than a specified pulse width.

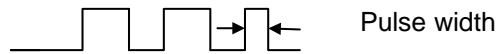

Video

Extracts a sync pulse from a video format signal, and triggers on a specific line or field.

Pulse and Runt

Triggers on a "runt". A runt is a pulse that passes a specified threshold but fails to pass a second threshold. Both positive and negative runs can be detected.

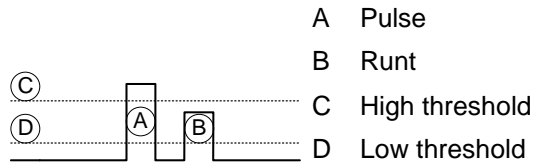

Rise and Fall

Trigger on rising and or falling edges, below or over a specified rate. The threshold can also be specified.

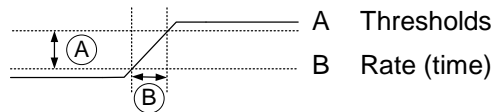



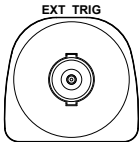
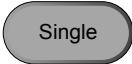

Trigger Parameter Overview

All the following parameters are common for all the trigger types unless stated otherwise.

Trigger Source	CH1 ~ 4	Channel 1 ~ 4 input signals	
	EXT	External trigger input signal	
	AC Line	AC mains signal	
	Alternate	Alternate between channel sources for the trigger source.	
	EXT Probe	Probe trigger source. Set the probe as either current or voltage.	
Trigger Mode	Auto (un-triggered roll)	The OSCILLOSCOPE generates an internal trigger if there is no trigger event, to make sure waveforms are constantly updated regardless of trigger events. Select this mode especially when viewing rolling waveforms at slower timebases.	
	Normal	The OSCILLOSCOPE acquires a waveform only when a trigger event occurs.	
	Single	The OSCILLOSCOPE acquires a waveform once when a trigger event occurs, then stops acquiring. Press the Single key to acquire a waveform again.	

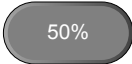

Coupling (Edge, Delay)	DC	DC coupling.
	AC	AC coupling. Blocks DC components from the trigger circuits.
	HF reject	High frequency filter above 50kHz
	LF reject	Low frequency filter below 50kHz
	Reject noise	DC coupling with low sensitivity to reject noise.

Slope (Edge, Delay, Rise & Fall)		Trigger on a rising edge.
		Trigger on a falling edge.
		Don't care. (Rise & Fall trigger type only)

Trigger Level (Edge, Delay)	Level	Adjusts the trigger manually using the Trigger LEVEL knob.	LEVEL 
	Set to TTL 1.4V	Sets the trigger level to 1.4V, suitable for triggering on TTL signals.	
	Set to ECL -1.3V	Sets the trigger to -1.3V. This is suitable for ECL circuits.	
	Set to 50%	Sets the trigger level to 50% of the waveform amplitude.	

Holdoff	Holdoff	Sets the holdoff time.
	Set to Minimum	Set the holdoff time to the minimum.

Delay (Delay)	Time	Sets the delay time (10ns ~ 10s) between the trigger event and the real trigger timing.
------------------	------	-----------------------------------------------------------------------------------------

	Event	Sets the number of events (1 ~ 65535) passed after the trigger event, until the real trigger timing.		
	Set to Minimum	Sets the source trigger to the minimum time.		
When (Pulse Width)	Sets the pulse width (4ns ~ 10s) and the triggering condition.			
	>	Longer than	=	Equal to
	<	Shorter than	≠	Not equal to
Threshold (Pulse Width)	Sets the amplitude threshold level for the pulse widths.			
	Threshold	-XXV ~ +XXV, user-set level		
	Set to TTL	1.4V		
	Set to ECL	-1.3V		
	Set to 50%	Sets the threshold to 50%		
Standard (Video)	NTSC	National Television System Committee		
	PAL	Phase Alternate by Line		
	SECAM	SEquential Couleur A Memoire		
	EDTV	480P (NTSC) (576p PAL)		
	HDTV	720P, 1080i, 1080P signals		
Polarity (Edge, Video)		Positive polarity (triggered on the high to low transition)		
		Negative polarity (triggered on the low to high transition)		
Trigger On	Selects the trigger point in the video signal.			
	Field	1 or 2 or all.		

(Video)	Line	1~263 for NTSC, 1~313 for PAL/SECAM, 1~ 525/625 for EDTV, 1~562/750/1125 for HDTV or all.
---------	------	-------------------------------------------------------------------------------------------

Threshold		Sets the upper threshold limit.
-----------	-----------------------------------------------------------------------------------	---------------------------------

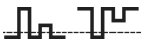
(Pulse Runt)		Sets the lower threshold limit.
--------------	-----------------------------------------------------------------------------------	---------------------------------

Set to TTL 1.4V

Set to ECL -1.3V

Threshold		High Sets the High threshold.
-----------	-----------------------------------------------------------------------------------	-------------------------------

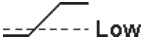
(Rise & Fall)		Low Sets the Low threshold.
---------------	-----------------------------------------------------------------------------------	-----------------------------

Set to TTL 1.4V

Set to ECL -1.3V

Setup Holdoff Level

Background

The holdoff function defines the waiting period before the OSCILLOSCOPE starts triggering again after a trigger point. The holdoff function ensures a stable display if there are a number of points in a periodic waveform that can be triggered. Holdoff applies to all the triggering types.

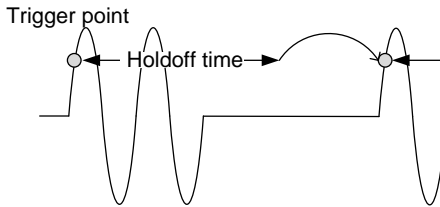

Panel Operation 1. Press the trigger *Menu* key.



2. To set the Holdoff time, press the *Holdoff* (or *Mode/Holdoff*) menu button on the bottom bezel.



3. Use the side menu to set the Holdoff time.

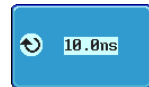

Range 10ns~10s

Pressing *Set to Minimum* sets the Holdoff time to the minimum, 10ns.

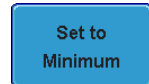

Note: The holdoff function is automatically disabled when the waveform update mode is in roll mode (page118).

Setup Trigger Mode

Background The trigger mode can be set to Normal or Auto (untriggered roll). The triggering mode applies to all the trigger types. See page 118.

Panel Operation 1. Press the Trigger menu key.

 A grey, rounded rectangular button with the word "Menu" in white text.

2. Press *Mode* from the bottom menu to change the triggering mode.

 A blue rectangular button with rounded corners. The word "Mode" is at the top and "Auto" is in a white box at the bottom.

3. Use the side panel to select *Auto* or *Normal* triggering modes.

Range Auto, Normal

Using the Edge Trigger

Panel Operation 1. Press the Trigger menu key.

 A grey, rounded rectangular button with the word "Menu" in white text.

2. Press *Type* from the lower bezel menu.

 A blue rectangular button with rounded corners. The word "Type" is at the top and "Edge" is in a white box at the bottom.

3. Select *Edge* from the side menu. The edge trigger indicator appears at the bottom of the display.

 A blue rectangular button with rounded corners and the word "Edge" in white text.

 A black rectangular display area showing three items: a blue circle with a white '2', a blue square with a white 'f', and the text "2.20V" in green.

From left: trigger source, slope, trigger level

4. Press *Source* to change the trigger source.

 A blue rectangular button with rounded corners. The word "Source" is at the top and "CH1" is in a white box at the bottom.

-
5. Use the side menu to select the trigger source type.

Range Channel 1 ~ 4 (Alternate On/Off),
Line, EXT; Ext Probe
(Volt/Current), AC Line

6. Press *Coupling* from the bottom bezel menu to select the trigger coupling or frequency filter settings.



7. Choose the coupling from the side menu.

Range DC, AC

8. Press *Reject* to toggle the rejection filter from the side menu.

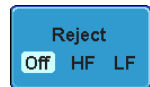

Range HF Reject, LF Reject, Off

9. Toggle *Noise Rejection* On or Off from the side menu.

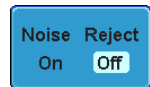

Range On, Off

10. From the bottom menu press *Slope* to toggle the slope type.



Range Rising edge, falling edge

11. To set the external trigger level, select *Level* from the bottom bezel menu.



12. Set the external trigger level using the side menu.

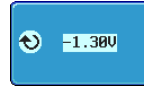

Range 00.0V~ 5 screen divisions
 Set to TTL 1.4V
 Set to ECL -1.3V
 Set to 50%

Using Advanced Delay Trigger

Background The EXT trigger source is always used as the delay triggering source.

- Panel Operation** 1. Press the trigger *Menu* key.



2. Press *Type* from the lower bezel menu.



3. Select *Delay* from the side menu. The delay + edge trigger indicator appears at the bottom of the display.



From left: external source, slope, trigger level, delay + external source

4. To set the delay press *Delay* from the bottom bezel.



-
- To Delay by Time, press *Time* from the side menu and set the delay time.



Range 10ns ~ 10s (by time)
Set to minimum

- To Delay by Event, press *Event* from the side menu and set the number of events.



Range 1 ~ 65535 events
Set to Minimum

Using Pulse Width Trigger

- Panel Operation
- Press the trigger *Menu* key.



- Press the *Type* key from the lower bezel menu.



- Select *Pulse Width* from the side menu. The pulse width trigger indicator appears at the bottom of the display.



From left: external source, polarity, when

- Press *Source* from the lower bezel.



5. Use the side menu to select the pulse width trigger source.

Range Channel 1 ~ 4 (Alternate On/Off),
Line, EXT; Ext Probe
(Volt/Current), AC Line

6. Press *Polarity* to toggle the polarity type.



Range Positive (high to low transition)
Negative (low to high transition)

7. Press *When* from the lower bezel.

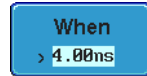

8. Then use the side menu to select the pulse width condition and width.

Condition >, <, =, ≠

Width 4ns ~ 10s

9. Press *Threshold* from the lower bezel to edit the pulse width threshold.



10. Use the side menu to set the threshold.

Range -XXV~XXV
Set to TTL 1.4V
Set to ECL -1.3V
Set to 50%

Using Video Trigger

Panel Operation 1. Press the trigger *Menu* key.

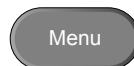

2. Press the *Type* key from the lower bezel menu.



3. Select *Video* from the side menu.
The video trigger indicator appears at the bottom of the display.



From left: channel, video standard, field, line

4. Press *Source* from the lower bezel.

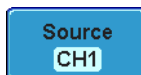

5. Use the side menu to select the video trigger source.

Range Channel 1 ~ 4

6. Press *Standard* on the bottom bezel.



7. Use the side menu to select the video standard.

Range NTSC, PAL, SECAM, EDTV
(480P/576P), HDTV
(720P/1080i/1080P)

8. Press *Trigger On* to edit the video field and line.



9. Use the side menu to select the field and line.

Field 1, 2, All

Video line NTSC: 1 ~ 262 (Even), 1 ~ 263 (Odd)
PAL/SECAM: 1 ~ 312 (Even),
1 ~ 313 (Odd),

EDTV(480P): 1~ 525, EDTV(576P):
1~ 625

HDTV(720P): 1~ 750, HDTV (1080i):
1 ~ 562 (even), 1~563 (odd), HDTV
(1080P): 1~1125, All

10. Press *Polarity* to toggle the polarity type.



Range positive, negative

Pulse Runt trigger

- Panel Operation 1. Press the trigger *Menu* key.

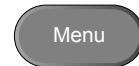

2. Press the *Type* key from the lower bezel menu.



3. Select *Others* → *Pulse Runt* from the side menu. The Pulse and Runt indicator appears at the bottom of the display.

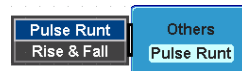

From left: Polarity, source, high/low threshold, threshold level

-
4. Press *Source* from the lower menu.



5. Use the side menu to select a source.

Range Channel 1 ~ 4

6. Press *Polarity* to toggle the polarity.

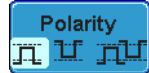

Range Rising edge, falling edge, either.

7. Press *When* from the lower menu.

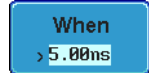

8. Then use the side menu to select the condition and width.

Condition > , < , = , ≠

Width 4ns ~ 10s

9. Press *Threshold* from the lower bezel to edit the threshold for each input source.

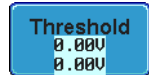

10. Use the side menu to set the upper threshold.

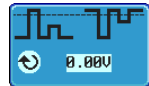

Range -XXV~XXV

Set to TTL 1.4V

Set to ECL -1.3V

11. Use the side menu to set the lower threshold.



Range -XXV~XXV
 Set to TTL 1.4V
 Set to ECL -1.3V

Using Rise and Fall Trigger

- Panel Operation 1. Press the trigger *Menu* key.



2. Press the *Type* key from the lower bezel menu.



3. Select *Others* → *Rise and Fall* from the side menu.

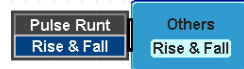

The Rise and Fall indicator appears at the bottom of the display.

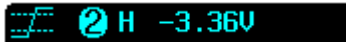

From left: rise and fall, source, high/low threshold, threshold level

4. Press *Source* from the lower menu.



5. Use the side menu to select a source.

Range Channel 1 ~ 4

-
6. Press *Slope* from the bottom menu to toggle the slope.



Range Rising edge, falling edge, either

7. Press *When* from the lower menu.



8. Then use the side menu to select the logic conditions and true or false status.

Condition > , < , = , ≠

Width 4ns ~ 10s

9. Press *Threshold* from the lower bezel to edit the threshold for each input source.



10. Use the side menu to set the threshold for the current input.

Range High: -XXV~XV

Low: -XXV~XXV

Set to TTL 1.4V

Set to ECT -1.3V

System Info / Language / Clock

This section describes how to set the interface, beeper, language, time/date, and probe compensation signal.

Select Menu Language

Parameter The following is a list of language available by default. Language selection may differ according to the region to which the OSCILLOSCOPE is shipped.

- English
- Chinese (traditional)
- Chinese (simplified)

Panel Operation 1. Press the *Utility* key.



2. Select the language from the side menu.



Range* English, Trad. Chinese, Simp. Chinese.

*Language selection may differ based on region.

View System Information

Panel Operation 1. Press the *Utility* key.



2. Press *System* from the lower menu.

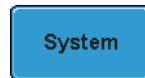

- Press *System Info* from the side menu. A display panel will appear showing:



- Manufacturer name
- Model name
- Serial number
- Firmware version
- Manufacturer URL

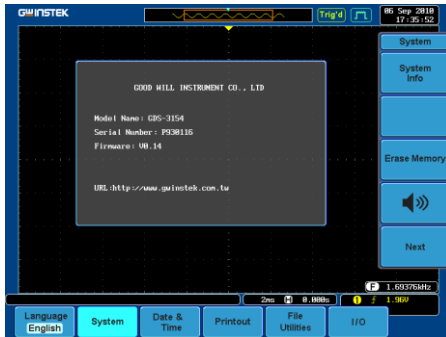

Erase Memory

Background The Erase Memory function will erase all internal waveforms, setup files and labels from internal memory.

Erased Items Waveform 1~20, Setting memory 1~20, Reference 1~4, Labels

Panel Operation 1. Press the *Utility* key.



2. Press *System* from the lower menu.

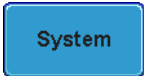

3. Press *Erase Memory* from the side menu.



A message will prompt you to press Erase Memory again to confirm the process.

4. Press *Erase Memory*.

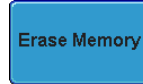

Set the Buzzer Volume

- Panel Operation 1. Press the *Utility* key.



2. Press *System* from the lower menu.

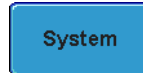

3. Press the buzzer icon on the side panel. Use the variable knob to set the volume.

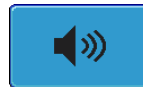

Set Date and Time

- Panel Operation/
Parameter 1. Press the *Utility* key.



2. Press *Date & Time* on the lower menu.



-
3. Set the *Year, Month, Day, Hour* and *Minute* from the side menu.

Year 2000 ~ 2037



Month 1 ~ 12



Day 1 ~ 31

Hour 1~23



Minute 0~59

4. Press *Save Now* from the side menu to save the date and time.



5. Make sure the date/time setting is correctly reflected at the top of the display.



SAVE/RECALL

File Format/Utility	152
Image File Format.....	152
Waveform File Format.....	152
Spreadsheet File Format	153
Setup File Format.....	154
Create/Edit file labels.....	156
Save	158
File Type/Source/Destination.....	158
Save Image.....	159
Save Image - Print Key.....	160
Save Waveform.....	162
Save Setup.....	163
Recall.....	165
File Type/Source/Destination.....	165
Recall Default Panel Setting	165
Recall Waveform	167
Recall Setup.....	168
Reference Waveforms	170
Recall and Display Reference Waveforms	170

File Format/Utility

Image File Format

Format	DSxxxx.bmp or DSxxxx.png
Contents	The current display image is 800 by 600 pixels. The background color can be inverted (Ink saver function). Each image file is numbered consecutively from DS0001 to DS9999.

Waveform File Format

Format	DSxxx.lsf, CH1~CH4.lsf	
	The LSF file format efficiently stores waveforms. This is the file format is used for storing and recalling waveforms that can be used for measurement with the OSCILLOSCOPE series.	
Waveform Type	CH1 ~ 4	Input channel signal
	Math	Math operation result (page 86)
Storage Location	Wave1 ~ Wave20	Waveform files stored to the internal memory. Stored waveforms can be copied to Ref. 1 ~ 4 to be viewed on the display. (W1 ~ W20 waveforms cannot be directly recalled on the display).

Ref 1~4 Reference waveforms stored in the internal memory, separate from W1 ~ W20. Reference waveforms (Ref 1 ~ 4) can be displayed directly onto the display with amplitude and frequency information. Ref 1~4 are useful for reference purposes. Other waveforms (LSF and W1~20) must be recalled to R1~4 before being displayed.

Contents: Waveform Data The waveform data can be used for detailed analysis. It consists of the horizontal and vertical data used by the waveform for the entire memory length.

Spreadsheet File Format

Format DSxxxx.csv (Comma-separated values format, can be opened in spreadsheet applications such as Microsoft Excel). CSV files cannot be recalled onto the OSCILLOSCOPE series of oscilloscopes.

Waveform Type CH1 ~ 4 Input channel signal
Math Math operation result (page86)

Contents: Waveform Data Digital waveform data containing the channel information such as vertical and horizontal position of a signal for the entire memory length.

Contents: Other Data The following information is also included in the waveform file.

- Firmware version
- Horizontal mode
- Trigger level
- Vertical scale
- Vertical position
- Time of acquisition
- Memory length
- Vertical units
- Probe level
- Horizontal units

- Horizontal scale
- Horizontal position
- Time (of points)
- Horizontal scale
- Sampling period
- Channel

Setup File Format

Format DSxxxx.set (proprietary format)
 The setup file saves or recalls the following settings.

Contents	Acquire	<ul style="list-style-type: none"> • Mode • Sample rate 	<ul style="list-style-type: none"> • XY • Sample mode
	Display	<ul style="list-style-type: none"> • Mode • Persistence • Waveform intensity 	<ul style="list-style-type: none"> • Graticule intensity • Waveform visuals • Graticule
	Channel	<ul style="list-style-type: none"> • Scale • Channel • Coupling • Impedance • Invert • Bandwidth 	<ul style="list-style-type: none"> • Expand • Position • Probe • Probe attenuation • Deskew
	Cursor	<ul style="list-style-type: none"> • Horizontal cursor 	<ul style="list-style-type: none"> • Vertical cursor
	Measure	<ul style="list-style-type: none"> • Source • Gating 	<ul style="list-style-type: none"> • Display
	Horizontal	<ul style="list-style-type: none"> • Scale 	
	Math	<ul style="list-style-type: none"> • Source1 • Operator • Source2 	<ul style="list-style-type: none"> • Position • Unit/Div • Math Off

Trigger	<ul style="list-style-type: none">• Type• Source• Coupling• Alternate• Rejection	<ul style="list-style-type: none">• Noise Rejection• Slope• Level• Mode• Holdoff
Utility	<ul style="list-style-type: none">• Language• Print key	<ul style="list-style-type: none">• Ink Saver
Save/ recall	<ul style="list-style-type: none">• Image file format	<ul style="list-style-type: none">• Data file format

Create/Edit file labels

Format Reference files and Setup files stored in internal memory can have individual labels set. The labels are used on the reference waveform and setup file icons.

Panel Operation 1. Press the *Save/Recall* key from the front panel.



2. Press *Edit File Label* from the bottom menu.



3. Press *Label For* to choose a Reference or Setup file.



Label For Ref1~4, Set1~20

4. To choose a preset label, Press *User Preset* from the side menu and choose a label.



Labels ACK, AD0, ANALOG, BIT, CAS, CLK, CLOCK, CLR, COUNT, DATA, DTACK, ENABLE, HALT, INT, IN, IRQ, LATCH, LOAD, NMI

Edit Label 1. Press *Edit Character* to edit the current label.

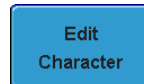

2. The Edit Label window appears.



3. Use the Variable knob to highlight a character.

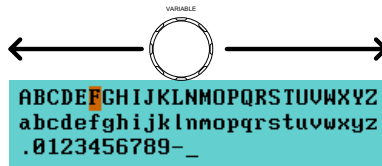

Press *Enter Character* to select a number or letter.

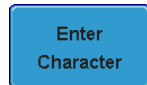

Press *Back Space* to delete a character.



Press *Editing Completed* to create the new label and return to the previous menu.

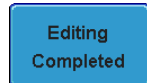

Cancel

Press *Cancel* to cancel the operation and return to the previous menu.



Save

File Type/Source/Destination

Item	Source	Destination
Panel Setup (DSxxxx.set)	<ul style="list-style-type: none"> • Front panel settings 	<ul style="list-style-type: none"> • Internal memory: Set1 ~ Set20 • File system: Disk, USB
Waveform Data (DSxxxx.csv) (DSxxxx.lsf) (CH1~CH4.lsf, Ref1~Ref4.lsf, Math.lsf)* ALLxxxx.csv	<ul style="list-style-type: none"> • Channel 1 ~ 4 • Math operation result • Reference waveform Ref1~4 • All displayed waveforms 	<ul style="list-style-type: none"> • Internal memory: Reference waveform Ref1~4, Wave1 ~ Wave20 • File system: Disk, USB
Display Image (DSxxxx.bmp) (DSxxxx.png)	<ul style="list-style-type: none"> • Display image 	<ul style="list-style-type: none"> • File system: Disk, USB

*Stored in ALLXXX directories when All Displayed waveforms are saved

Save Image

- Panel Operation
- To save to USB, connect a USB drive to the front or rear panel USB port. If a USB drive is not connected, images will be saved to the internal memory.
Note: Only one host connection, front or rear, is allowed at a time.

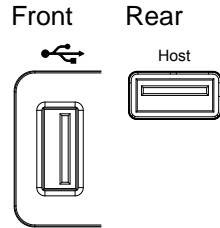

- Press the *Save/Recall* key from the front panel.



- Press *Save Image* from the bottom menu.



- Press *File Format* to choose PNG or BMP file types.



Range DSxxxx.bmp, DSxxxx.png

- Press *Ink Saver* to toggle Ink Saver On or Off.

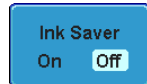

Ink Saver On

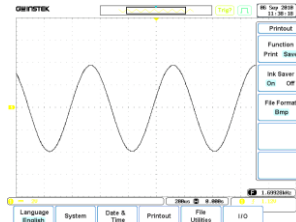

Ink Saver Off

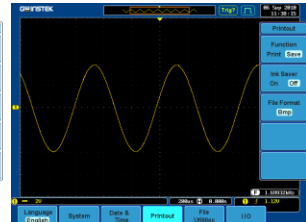

- Press *Save Now* from the side menu to save the display as an image file.



Note

The file will not be saved if the power is turned Off or the USB drive is taken out before the message ends.

USB File Utility To edit the USB flash drive contents (create/ delete/ rename files and folders) or to edit the default file path, press *File Utilities* from the side menu. See page 171 for details.



Save Image - Print Key

Background The Print key can be assigned to Print or to Save. When assigned to Save, pressing the Print key will save a screen image to USB. Images cannot be saved to internal memory using the Print key.

- Panel Operation**
- Connect a USB drive to the front or rear panel USB port. Note: Only one host connection, front or rear, is allowed at a time.

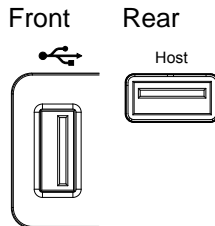

- Press the *Utility* key.



- Press *Printout* from the bottom menu.



- On the side menu, press *Function* repeatedly to select Save.



The Save led on the screen bezel will be lit when the printout function is set to *Save*.



- Press the *Print* key to save to USB



Ink Saver

To invert the color for the saved or printed display image, press Ink Saver repeatedly to toggle Ink Saver On or Off from the side menu.



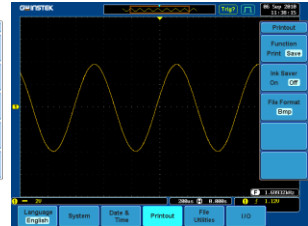
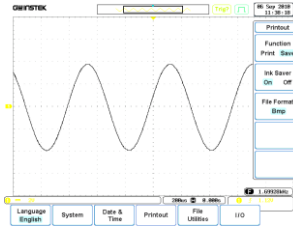

Ink Saver On (Inverted)

Ink Saver Off (Normal)



Waveform save to Disk:~/DS0001.CSV completed!



Note  The file will not be saved if the power is turned Off or the USB drive is taken out before the message ends.

USB File Utility To edit USB flash drive contents (create/ delete/ rename files and folders), press *File Utilities*. For details, see page 171. 

PC Software (FreeWave) Saving waveforms can also be accomplished using FreeWave 

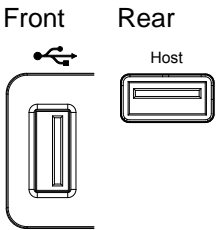
Save Setup

- Panel Operation
- (For saving to an external USB flash drive) Connect the drive to the front or rear panel USB port. 

Note: Only one host connection, front or rear, is allowed at a time.
 - Press the *Save/Recall* key from the front panel. 
 - Press *Save Setup* from the bottom menu. 
 - Press *To* (internal memory) or *To File* and choose a destination to save. 
- To Set1~Set20

To File DSxxxx.set

5. Press *Save Now* to confirm saving. When completed, a message appears at the bottom of the display.



Note 

The file will not be saved if the power is turned Off or the USB drive is taken out before the message ends.

USB File Utility To edit USB flash drive contents (create/ delete/ rename files and folders) or to set the file path, press *File Utilities*. For details, see 171.



Edit Label To edit labels for Setup files, press *Edit Label*. For more details on editing labels, see page 156.



Recall

File Type/Source/Destination

Item	Source	Destination
Default Panel Setup	<ul style="list-style-type: none"> Factory installed setting 	<ul style="list-style-type: none"> Current front panel
Reference Waveform	<ul style="list-style-type: none"> Internal memory: Ref1~4 	<ul style="list-style-type: none"> Current front panel
Panel Setup (DSxxxx.set)	<ul style="list-style-type: none"> Internal memory: S1 ~ S20 File system: Disk, USB 	<ul style="list-style-type: none"> Current front panel
Waveform Data (DSxxxx.lsf) (CH1~CH4.lsf, Ref1~Ref4.lsf, Math.lsf)*	<ul style="list-style-type: none"> Internal memory: Wave 1 ~ Wave20 File system: Disk, USB 	<ul style="list-style-type: none"> Reference waveform 1 ~ 4

*Recalled from ALLXXX directories.

Recall Default Panel Setting

Panel Operation 1. Press the *Default Setup* key.



2. The screen will update with the default panel settings.

Setting Contents The following is the default (factory) setting contents.

Acquire	Mode: Sample	XY: OFF
	Sample mode: Sinc	Sample rate: 250MSPS
Display	Mode: Vector	Persistence: Auto
	Waveform intensity: 50%	Graticule intensity: 50%
	Waveform visuals: Gray	Graticule: full 
Channel	Scale: 100mV/Div	CH1: On
	Coupling: DC	Impedance: 1MΩ
	Invert: Off	Bandwidth: full
	Expand: By ground	Position: 0.00V
	Probe: voltage	Probe attenuation: 1x
	Deskew: 0s	
Cursor	Horizontal cursor: Off	Vertical Cursor: Off
Measure	Source: CH1	Gating: Off
	Display: Off	
Horizontal	Scale: 10us/Div	
Math	Source1: CH1	Operator: +
	Source2: CH2	Position: 0.00 Div
	Unit/Div: 200mV	Math Off
Test	App: Go-NoGo	
Trigger	Type: Edge	Source: CH1
	Coupling: DC	Alternate: Off
	Rejection: Off	Noise Rejection: Off
	Slope: positive	Level: 0.00V
	Mode: Auto	Holdoff: 10.0ns
Utility	Language: English	Print key: Save
		Ink Saver: On
Save Recall	Image file format: Bmp	Data file format: LSF

Recall Waveform

- Panel Operation 1. (For recalling from an external USB flash drive)
 Connect the drive to the front or rear panel USB port.
 Note: Only one host connection, front or rear, is allowed at a time.

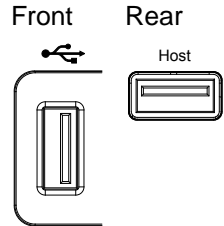

2. The waveform must be stored in advance. See page 160 for waveform store details.
3. Press the *Save/Recall* key.



4. Press *Recall Waveform* from the bottom menu. The Recall menu appears.

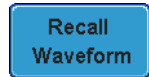

5. Press *From* (internal memory) or *From File* and choose a source to recall from.



From Wave1~20

From File* DSxxxx.lsf, CH1~CH4.lsf

*Only files in the current file path will be available, this includes files saved in the ALLXXX directories.

6. Press *To* and select the reference waveform to recall to.

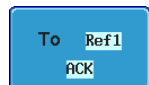

To Ref1~4

7. Press *Recall Now* to recall the waveform.

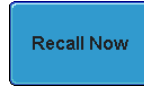

- USB File Utility To edit USB flash drive contents (create/ delete/ rename files and folders) or to set the file path, press *File Utilities*. For details, see page 171.



Recall Setup

- Panel Operation 1. (For recalling from an external USB flash drive) Connect the drive to the front or rear panel USB port. Note: Only one host connection, front or rear, is allowed at a time.

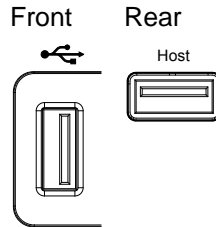

2. Press the *Save/Recall* key.



3. Press *Recall Setup* from the bottom menu.



4. Press *From* (internal memory) or *From File* and choose a source to recall from.

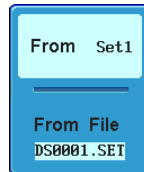

From Set1~20

From File DSxxxx.set (USB, Disk)*

* Only files in the current file path will be available.

5. Press *Recall Now* to confirm recalling. When completed, a message appears at the bottom of the display.

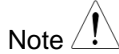
A blue rectangular button with rounded corners and a thin black border, containing the text "Recall Now" in black.An orange rectangular message box with rounded corners and a thin black border, containing the text "Setup recalled from Set1!" in black.

The file will not be saved if the power is turned Off or the USB drive is taken out before the message ends.

USB File Utility To edit USB flash drive contents (create/ delete/ rename files and folders) or to set the file path, press *File Utilities*. For details, see page 171.

A blue rectangular button with rounded corners and a thin black border, containing the text "File Utilities" in black.

Edit Label To edit labels for Setup files, press *Edit label*. For more details on editing labels, see page 156.

A blue rectangular button with rounded corners and a thin black border, containing the text "Edit Label" in black.

Reference Waveforms

Recall and Display Reference Waveforms

Panel Operation A reference waveform must be stored in advance. See page 160 to store waveforms as reference waveforms.

1. Press the *REF* key on the front panel.





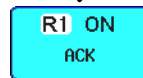



2. Pressing *R1~R4* repeatedly will toggle the corresponding reference waveform OFF/ON.

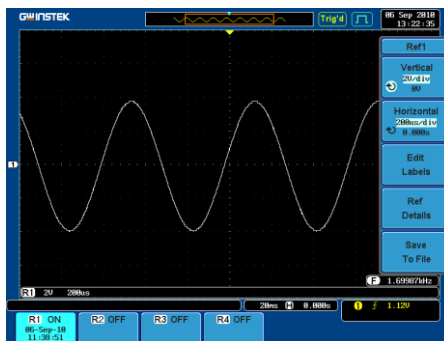
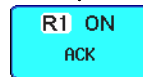
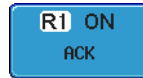

Turning *R1~R4* ON will open the corresponding reference menu.

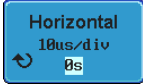
3. If a reference waveform is ON but not active, its reference menu can be opened by pressing the corresponding *R1~R4* key from the bottom menu.



Vertical Navigation	Press <i>Vertical</i> repeatedly from the side menu to choose to edit the vertical position or Volts/Div. Use the Variable knob to edit the values.	
Horizontal Navigation	Press <i>Horizontal</i> repeatedly from the side menu to choose to edit the Time/Div or the horizontal position. Use the Variable knob to edit the value.	
View Reference Waveform Details	Pressing <i>Ref Details</i> will display the reference waveform details.	
<p style="text-align: center;">Details Sample Rate, Record Length, Date</p> <div style="border: 1px solid black; padding: 5px; margin: 10px auto; width: fit-content;"> <p style="text-align: center;">Sample Rate: 10MSPS Record Length: 25000 points Date: 06-Sep-10 11:38:51</p> </div>		
Edit Labels	To edit labels for Setup files, press <i>Edit labels</i> . For more details on editing labels, see page 156.	
Save Reference Waveforms	To save reference waveforms, press <i>Save to File</i> . For more Details on saving waveforms, see page 152.	

FILE UTILITIES

The file utilities are used each time files need to be saved to internal or external memory. The file utilities can create directories, delete directories and rename files. BMP and PNG image files can be previewed in the file system. The File Utilities menu also sets the file path for saving and recalling files from the Save/Recall menu.

File Navigation.....	174
Create Folder.....	176
Rename File.....	177
Delete File.....	179

File Navigation

The File Utilities menu can be used to choose files or to set the file path for saving/recalling files.

File System

File path

Drive space

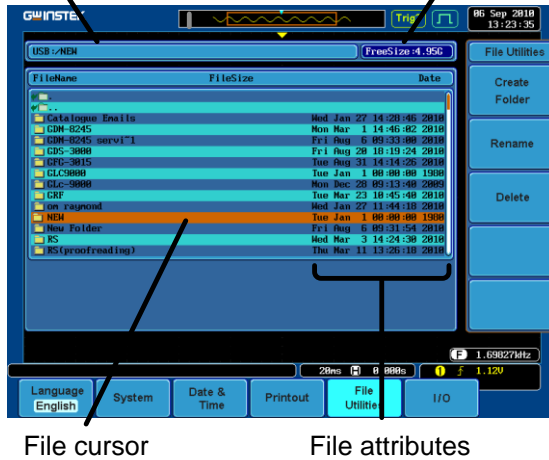

File cursor

File attributes

Panel Operation 1. Press the *Utility* key.

Utility

2. Press *File Utilities* from the bottom menu.

File
Utilities

3. The file system appears.

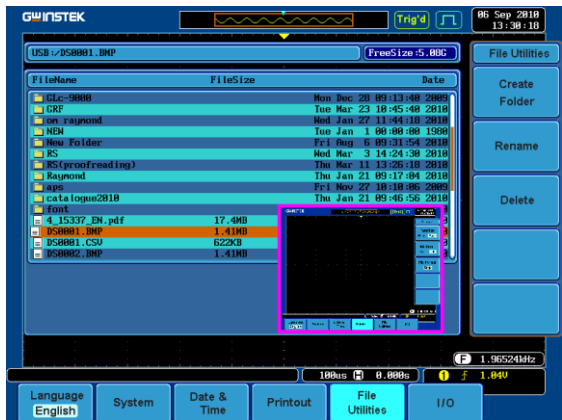

4. Use the *Variable* knob to move the file cursor up and down.



Use the *Select* key to choose a file or directory or to set the file path.

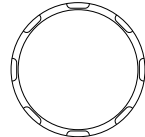

The file path can be set to internal memory or to a directory on a USB memory stick.



Note

Selecting a waveform file will cause that file to be recalled to the currently configured reference waveform.

Create Folder

Panel Operation 1. Press the *Utility* key.



2. Press *File Utilities* from the bottom menu.



3. Use the variable knob and select key to navigate the file system.



Create Folder

4. Press *Create Folder* to make a new directory at the selected location.

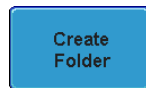

5. Use the *Variable* knob to highlight a character.



Press *Enter Character* to select a number or letter.

Enter
Character

Press *Back Space* to delete a character.

Back
Space

6. Press *Editing completed* to create the folder name.

Editing
Completed

Cancel

Press *Cancel* to cancel the operation.

Cancel

Rename File

- Panel Operation 1. Press the Utility key.

Utility

2. Press *File Utilities* from the bottom menu.

File
Utilities

3. Use the variable knob and select key to choose a file to rename.

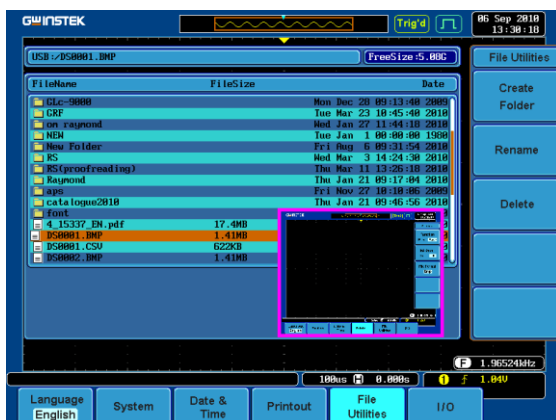

4. Press *Rename* when a file is chosen.

A blue rectangular button with rounded corners and a thin black border, containing the text "Rename" in white.

5. Use the *Variable* knob to highlight a character.

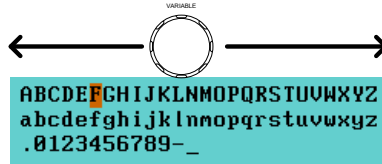

Press *Enter Character* select a number or letter.

A blue rectangular button with rounded corners and a thin black border, containing the text "Enter Character" in white.

Press *Back Space* to delete a character.

A blue rectangular button with rounded corners and a thin black border, containing the text "Back Space" in white.

6. Press *Editing completed* to create the folder or file name.

A blue rectangular button with rounded corners and a thin black border, containing the text "Editing Completed" in white.

Delete File

Panel Operation 1. Press the *Utility* key.



2. Press *File Utilities* from the bottom menu.



3. Use the variable knob and select key to navigate the file system to choose a file.

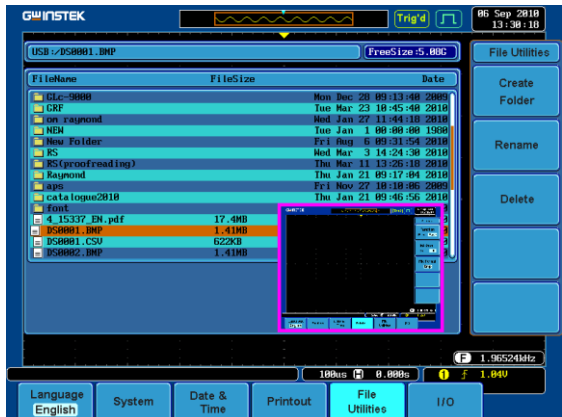

4. Press *Delete* to delete the selected file.

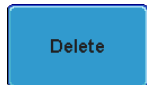

5. Press *Delete* again to confirm the deletion.

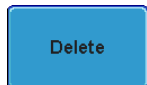

PRINT OUT

Screen images can be printed to some PictBridge compatible printers using the USB device port. The OSCILLOSCOPE has a dedicated Print key for quick and easy printing. To reduce the amount of printer ink used for each print, images can be printed using the Ink Saver function.

Screen images can also be printed using the remote control software, FreeWave.

Printer I/O Configuration

Panel Operation 1. Connect a PictBridge printer to the USB device port on the rear panel.



2. Press the *Utility* key.



3. Press *I/O* from the bottom menu.

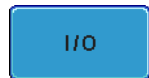

4. Press *USB Device Port* from the side menu and select *Printer*.



Print Output

Ensure the USB port has been configured to the Printer before trying to print, see page 181.

Panel Operation 1. Press the *Utility* key.



2. Press *Printout* from the bottom menu.



3. On the side menu, press *Function* repeatedly to select Print.

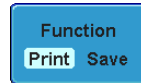

4. The Print led on the screen bezel will be lit when the printout Function is set to *Print*.

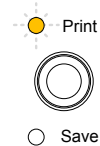

5. Press the Print key located on the screen bezel. The display image is printed out.

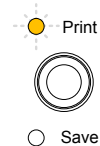

Ink Saver

To have a white background on the saved or printed display image, press *Ink Saver* repeatedly to toggle Ink Saver On or Off from the side menu.

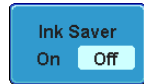

Ink Saver On

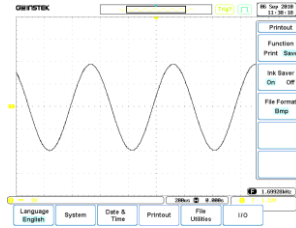

Ink Saver Off

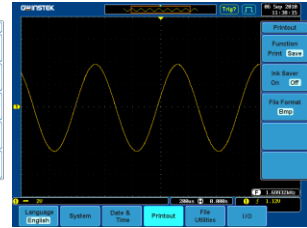

REMOTE CONTROL

CONFIG

This chapter describes basic configuration for remote control. For a command list, refer to the programming manual.

Interface Configuration	186
Configure USB Interface.....	186
Configure RS-232C Interface.....	187
Configure the Ethernet Interface	188
Configure GPIB Interface	191
USB/RS-232C Remote Control Software	192

Interface Configuration

Configure USB Interface

USB Configuration	PC side connector	Type A, host
	OSCILLOSCOPE side connector	Type B, slave
	Speed	1.1/2.0 (high speed)
	USB Class	CDC (communications device class)

Panel Operation 1. Press the Utility key.



2. Press I/O from the bottom menu.



3. Press USB Device Port from the side menu.



4. Press *Computer* from the side menu.



5. Connect the USB cable to the rear panel slave port.



6. When the PC asks for the USB driver, select the USB driver included in the FreeWave software, the OSCILLOSCOPE product corner. The driver file automatically sets the OSCILLOSCOPE as a serial COM port.

Configure RS-232C Interface

RS-232C Configuration	Connector	DB-9, Male
	Baud rate	2400, 4800, 9600, 19200, 38400, 57600, 115200
	Parity	None, Odd, Even
	Data bit	8 (fixed)
	Stop bit	1, 2

Panel Operation 1. Press the *Utility* key.



2. Press *I/O* from the bottom menu.

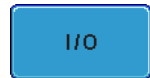

3. Press *RS-232C* from the side menu.



4. Use the side menu to set the Baud Rate.

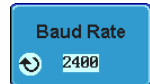

Baud Rate 2400, 4800, 9600, 19200, 38400, 57600, 115200

5. Press *Stop Bit* to toggle the number of stop bits.



Stop Bits 1, 2

6. Press *Parity* to toggle the parity.

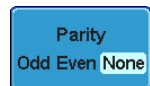

Parity Odd, Even, None

7. Connect the RS-232C cable to the rear panel port: DB-9 male connector. For a functionality check, see page 192.

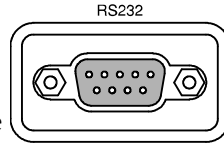

Pin Assignment

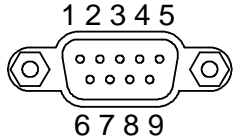

- 2: RxD (Receive data)
- 3: TxD (Transmit data)
- 5: GND
- 4, 6 ~ 9: No connection

PC Connection Use the Null Modem connection as in the below diagram.

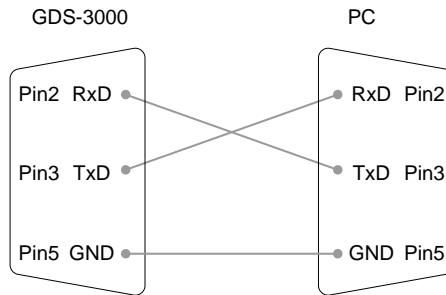

Configure the Ethernet Interface

Ethernet Configuration	MAC Address	Domain Name
	Instrument Name	DNS IP Address
	User Password	Gateway IP Address
	Instrument IP Address	Subnet Mask
		HTTP Port 80 (fixed)

Background The Ethernet interface is used for remote control over a network.

Panel Operation 1. Press the *Utility* key.



2. Press *I/O* from the bottom menu.

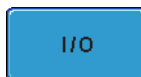

3. Press *Ethernet* from the side menu.



4. Set *DHCP/BOOTP* to *On* or *Off* from the side menu.

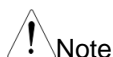
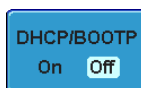

IP addresses will automatically be assigned with DHCP/BOOTP set to on. For Static IP Addresses, DHCP/BOOTP should be set to off.

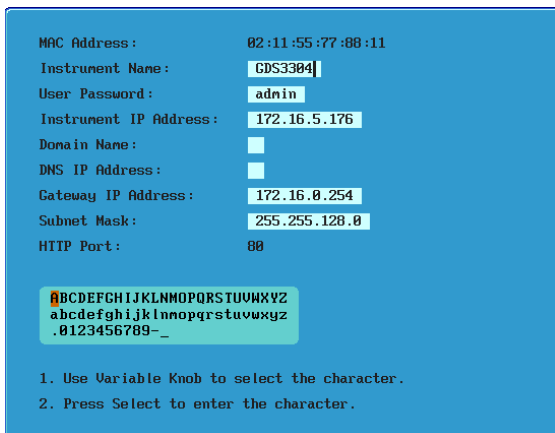

5. Use the *Up* and *Down* arrows on the side menu to navigate each Ethernet configuration item.



Items MAC Address, Instrument Name,
 User Password, Instrument IP
 Address, Domain Name, DNS IP
 Address, Gateway IP Address,
 Subnet Mask

Note: HTTP Port is fixed at 80.

- Use the Variable knob to highlight a character and use the Select key to choose a character.

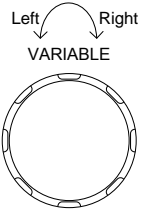

Press *Backspace* to delete a character.







- Connect the Ethernet cable to the rear panel of the OSCILLOSCOPE.

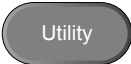

Configure GPIB Interface

To use GPIB, the optional GPIB to USB (GUG-001) adapter must be used. The GPIB address can be configured for the GUG-001 from the utility menu. See the GUG-001 user manual for more information.

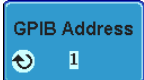
- Configure GPIB
1. Insert the GUG-001 USB cable into the rear panel USB device port. 
 2. Press the *Utility* key. 
 3. Press *I/O* from the bottom menu. 
 4. Press USB Device Port from the side menu. 
 5. Press *GPIB* from the side menu. 
 6. Use the variable knob to set the GPIB Address from the side menu. 
- Range 1 ~ 30
-

GPIB Constraints

- Maximum 15 devices altogether, 20m cable length, 2m between each device
- Unique address assigned to each device
- At least 2/3 of the devices turned On
- No loop or parallel connection

USB/RS-232C Remote Control Software

Terminal Application (USB/RS-232C)	<p>Invoke the terminal application such as MTTY (Multi-Threaded TTY). For RS-232C, set the COM port, baud rate, stop bit, data bit, and parity accordingly.</p> <p>To check the COM port No, see the Device Manager in the PC. For WinXP, Control panel → System → Hardware tab.</p>
Functionality Check	<p>Key in this query command via the terminal.</p> <pre>*idn?</pre> <p>This should return the Manufacturer, Model number, Serial number, and Firmware version</p>
PC Software (USB only)	<p>The proprietary PC software FreeWave is for remote control.</p>

M AINTENANCE

Two types of maintenance operations are available: calibrate vertical accuracy, and compensate the probe. Run these operations when using the OSCILLOSCOPE in a new environment.

Vertical Accuracy Calibration.....	194
Probe Compensation	195
Activating Optional Software.....	197

Vertical Accuracy Calibration

Panel Operation 1. Press the *Utility* key.

 Utility

2. Press *System* from the bottom menu.

 System

3. Press *NEXT* from the side menu.



 Next

4. Press *Self Cal* on the side menu.

 Self Cal

5. A message appears to “Set CAL to CH1, then press Self Cal”.

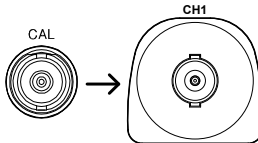
6. Connect the calibration signal from the rear panel to the Channel1 input with a BNC cable.



7. Press *Self Cal* again after connecting *CAL* to the channel 1 input.

 Self Cal

The calibration for Channel1 starts and ends automatically, in less than 5 minutes. A message is displayed when the calibration procedure has ended.

8. Repeat the above step for Channel 2, 3* and 4* when prompted.

*4 channel models.

9. When the calibration for all channels has completed, the display goes back to the default state.

Probe Compensation

- Panel Operation
1. Connect the probe between the Channel1 input and the probe compensation output (2Vp-p, 1kHz square wave) on the front panel. Set the probe attenuation to x10 (GDP probes are fixed at x10).

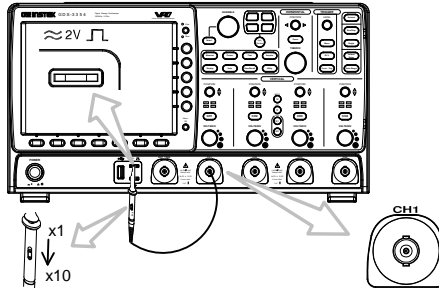

2. Press the *CH1* key to activate CH1.



3. Set the *Coupling* to DC from the bottom menu.

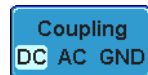

4. Set *Impedance* to 1MΩ from the bottom menu.

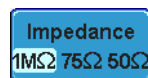

5. Set the Probe attenuation to *Voltage, 10X*. Page 126

6. Press the *Autoset* key. The compensation signal appears on the display.



7. Press the *Display* key, then set the display type to *Vector*.

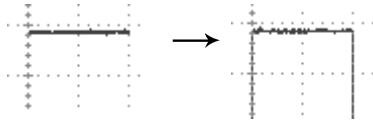
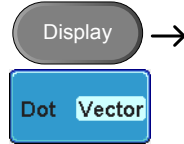

8. Turn the adjustment point on the probe to make the waveform as square as possible.

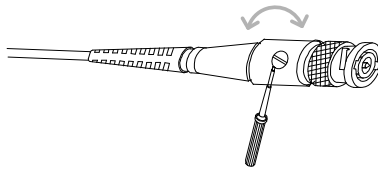
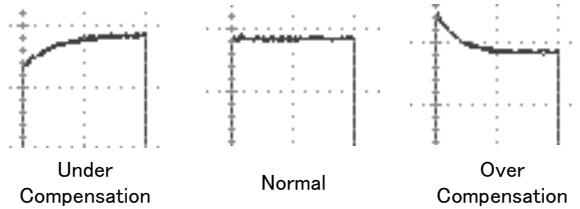

Activating Optional Software

Background The OSCILLOSCOPE has Power Analysis software (page 98) and Serial bus decoding software (page 99) and. An activation key is required to activate the software. An activation key is required for each optional software package.

FAQ

- I connected the signal but it does not appear on the display.
- I want to remove the (Measurement result / FFT result / Help contents) from the display.
- The waveform does not update (frozen).
- The probe waveform is distorted.
- Autoset does not catch the signal well.
- I can't save files to the internal memory.
- The display image printout is too dark on the background.
- The date and time setting are not correct.
- The accuracy does not match the specification.

I connected the signal but it does not appear on the display.

Make sure you have activated the channel by pressing the Channel key (the channel key lights up).

I want to remove the (Measurement result / FFT result / Help contents) from the display.

To clear automatic measurement results, press the Measure key, Select Remove Measurement and choose Remove All. See page 76.

To clear individual measurements from the screen, press the Measure key, select Display All and choose Display None. See page 78.

To clear FFT result, press the Math key twice. See page 86 for details.

To clear Help result, press the Help key again. See page 59 for details.

The waveform does not update (frozen).

Press the Run/Stop key to unfreeze the waveform. See page 65 for details.

If this does not help, the trigger mode might be set to Single. Press the Single key to exit Single mode. See page 65 for trigger setting details.

The probe waveform is distorted.

You might need to compensate the probe. The input impedance may also have to be changed to suit your probe. For details, see page 195. Note that the frequency accuracy and duty factor are not specified for the probe compensation waveform and therefore it should not be used for other reference purposes. Also remember to set the impedance to $1M\Omega$.

Autoset does not catch the signal well.

The Autoset function cannot catch signals under 30mV or 20Hz. Please use the manual operation. See page 64 for Autoset details.

I can't save files to the internal memory.

If a USB stick is inserted into one of the USB slots and you wish to save to the scope internal memory, press the *Utilities* key and set the file path to internal memory. Note however that image files can only be saved to USB when using the Print key.

The display image printout is too dark on the background.

Use the Ink Saver function which reverses the background color. For details, see page 181.

The date and time setting are not correct.

For date and time setting details, please see page 148. If it does not help, the internal battery controlling the clock might be worn out. Contact your dealer.

The accuracy does not match the specification.

Make sure the device is powered On for at least 30 minutes, within +20°C~+30°C. This is necessary to stabilize the unit to match the specification.

APPENDIX

OSCILLOSCOPE Specifications

The specifications apply when the OSCILLOSCOPE is powered on for at least 30 minutes under +20°C~+30°C.

Model-specific

6152	Channels	2 + Ext
	Bandwidth	DC ~ 150MHz (-3dB)
	Rise time	2.3ns
6154	Channels	4 + Ext
	Bandwidth	DC ~ 150MHz (-3dB)
	Rise time	2.3ns
6252	Channels	2 + Ext
	Bandwidth	DC ~ 250MHz (-3dB)
	Rise time	1.4ns
6254	Channels	4 + Ext
	Bandwidth	DC ~ 250MHz (-3dB)
	Rise time	1.4ns
6352	Channels	2 + Ext
	Bandwidth	DC ~ 350MHz (-3dB)
	Rise time	1ns
6354	Channels	4 + Ext
	Bandwidth	DC ~ 350MHz (-3dB)
	Rise time	1ns

The bandwidth of the 75Ω input impedance is limited to 150MHz only.

Common

Vertical	Resolution	8 bit @1MΩ: 2mV~5V @50/75Ω: 2mV~1V
	Input Coupling	AC, DC, GND
	Input Impedance	1MΩ// 15pF
	DC Gain	±(3% X Readout + 0.1div + 1mV)
	Accuracy	
	Polarity	Normal & Invert
	Maximum Input Voltage	@1 MΩ: 300V (DC+AC Peak), CAT I @50/75Ω: 5 VRMS max
	Offset Position	2mV/div ~ 100mV/div : ±0.5V
	Range	200mV/div ~ 5V/div : ±25V
	Bandwidth Limit	Dependent on the oscilloscope bandwidth (BW. BW=150: Full, 20MHz BW=250: Full, 20MHz, 100MHz BW=350: Full, 20MHz, 100MHz, 200MHz
	Waveform Signal Process	Add, subtract, multiply, and divide waveforms, FFT, FFTrms FFT:Spectral magnitude. Set FFT Vertical Scale to Linear RMS or dBV RMS, and FFT Window to Rectangular, Hamming, Hanning, or Blackman-Harris.
Trigger	Sources	CH1 ,CH2,Line ,EXT (CH3, CH4 for 4 channel models)
	Modes	Auto (supports Roll Mode for 100 ms/div and slower), Normal, Single
	Type	Edge, Pulse Width, Video, Pulse Runt, Rise & Fall, Alternate, Event-Delay(1~65535 events), Time-Delay(10nS~10S), I ² C*, SPI*, UART* *optional Runt: Trigger on a pulse that crosses one threshold but fails to cross a second threshold before crossing the first again. SPI (optional): Trigger on SS, MOSI, MISO, or MOSI and MISO on SPI buses. I ² C (optional): Trigger on Start, Repeated Start, Stop, Missing ACK, Address (7 or 10 bit), Data, or Address and Data on I ² C buses.

		UART (optional): Trigger on Tx Start Bit, Rx Start Bit, Tx End of Packet, Rx End of Packet, Tx Data, Rx Data, Tx Parity Error, and Rx Parity Error.
	Holdoff range	10nS to 10S
	Coupling	AC,DC,LF rej. ,Hf rej. ,Noise rej.
	Sensitivity	DC ~ 50MHz Approx. 1div or 10mV 50MHz ~ 150MHz Approx. 1.5div or 15mV 150MHz ~ 350MHz Approx. 2div or 20mV
External Trigger	Range	±15V
	Sensitivity	DC ~ 150MHz Approx. 100mV 150MHz ~ 350MHz Approx. 150mV
	Input Impedance	1MΩ/15pF
Horizontal	Range	1ns/div ~ 100s/div (1-2-5 increments); ROLL : 100ms/div ~ 100s/div
	Pre-trigger	10 div maximum
	Post-trigger	1000 div maximum. The number of divisions depends on the time division.
	Accuracy	±20 ppm over any ≥ 1 ms time interval
X-Y Mode	X-Axis Input	Channel 1;Channel 3, Ref1, Ref3
	Y-Axis Input	Channel 2;Channel 4, Ref2, Ref3
	Phase Shift	±3° at 100kHz
Signal Acquisition	Real Time	5GSa/s (MAX)
	Sample Rate	150 & 250MHz 2CH: 2.5GSa/s
	ET Sample Rate	100GSa/s maximum for all models
	Record Length	25k points
	Acquisition Mode	Normal, Average, Peak Detect, High Resolution
	Peak Detection	2nS (MAX)
		Normal: Acquire sampled values. Average: From 2 to 256 waveforms included in average. Peak Detect: Captures glitches as narrow as 2 ns at all sweep speeds Hi Res: Increases the sample rate. Averages the samples from each acquisition interval (bucket).

Cursors and Measurement	Cursors	Amplitude, Time, Gating available
	Automatic Measurement	28 sets: Vpp, Vamp, Vavg, Vrms, Vhi, Vlo, Vmax, Vmin, Rise Preshoot/Overshoot, Fall Preshoot/Overshoot, Freq, Period, Rise Time, Fall Time, Positive Width, Negative Width, Duty Cycle, and nine different delay measurements (FRR, FRF, FFR, FFF, LRR, LRF, LFR, LFF, Phase)
	Cursors measurement	Voltage difference between cursors (ΔV) Time difference between cursors (ΔT)
	Auto counter	6 digits, range from 2Hz minimum to the rated bandwidth
Power Measurements (Option)	Power Quality Measurements	V RMS, I RMS, True Power, Apparent Power, Reactive Power, Frequency, Power Factor, Phase Angle, V Crest Factor, I Crest Factor, (+)V Peak, (-)V Peak, (+)I Peak, (-)I Peak, DC Voltage, DC Current, Impedance, Resistance, Reactance
	Harmonics	Frequency (Hz), Magnitude (%), Mag. RMS (A), Phase ($^{\circ}$), Limit (A), Limit (%), Pass Fail, Max all , Windows (A), 200% Limit, POHC Limit, THD-F, THD-R, RMS, Overall, POHC, POHL, Input Power, Power Factor, Fundamental Current, Harmonic 3, Harmonic 5
	Ripple Measurements	Ripple, Noise
	In-rush current	First peak, Second peak
Control Panel Function	Autoset	Single-button, automatic setup of all channels for vertical, horizontal and trigger systems, with undo autoset
	Auto-Range	allow users to quickly move from test point to test point without having to reset the oscilloscope for each test point
	Save Setup	20set
	Save Waveform	24set
Display	TFT LCD Type	8" TFT LCD SVGA color display
	Display Resolution	800 horizontal \times 600 vertical pixels (SVGA)
	Interpolation	Sin(x)/x & Equivalent Time Sampling
	Waveform Display	Dots, vectors, variable persistence, infinite persistence
	Display Graticule	8 x 10 divisions
Interface	RS232C	DB-9 male connector

	USB Port	2 sets USB 2.0 High-speed host port ;1 set USB High-speed 2.0 device port
	Ethernet Port	RJ-45 connector, 10/100Mbps
	SVGA Video Port	DB-15 female connector, monitor output for display on SVGA monitors
	GPIB	GPIB to USB adapter (Option)
	Go-NoGo BNC	5V Max,10mA TTL /16V Max, 10mA CMOS open collector output
	Internal flash disk	64MB
	Kensington Style Lock	Rear-panel security slot connects to standard Kensington-style lock.
	Line output	1 Vpp (typ)
	Trigger out BNC	5V TTL output
Power Source	Line Voltage Range	AC 100V ~ 240V , 47Hz ~ 63Hz , Auto selection
	Power Consumption	96VA
Miscellaneous	Multi-language menu	Available
	On-line help	Available
	Time clock	Time and Date ,Provide the Date/Time for saved data
Dimensions	400W X 200H X 130D, Approx. 4kg	

Common

Position x 10	Attenuation Ratio	10:1 (fixed) with readout pin
	Input Resistance	10M Ω when used with 1M Ω input oscilloscope
	Compensation Range	10 ~ 30pF
	Maximum Input Voltage	500V CAT I, 300V CAT II (DC+Peak AC) Derating with frequency
Operating Condition	Temperature	-0°C ~ 50°C
	Relative Humidity	$\leq 85\%$ @35°C
Safety Standard	EN61010-031 CAT II	

OSCILLOSCOPE Dimensions

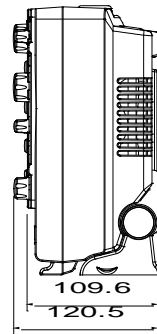
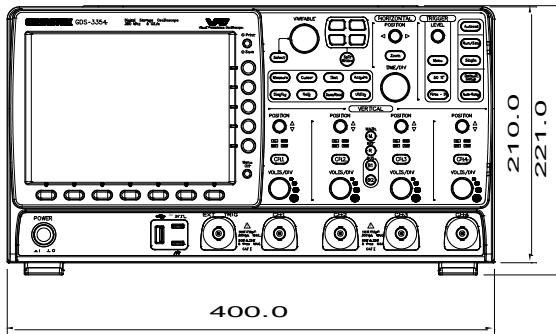
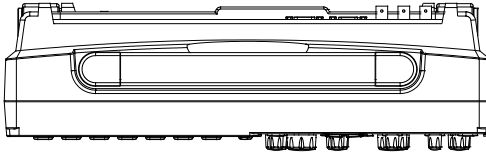

I NDEX

2-4 channel differences	15	horizontal.....	80
AC coupling.....	122	specification.....	206
Acquisition	103	vertical.....	83
indicator	30	Cycle time measure	73
Sampling mode.....	107	Date setting.....	148
specification	205	indicator	30
XY mode.....	105	DC coupling	122
APP.		Default setup	165
Go-NoGo.....	93	contents.....	57, 154, 166
overview.....	91	effect on channel	64
run.....	91	Delay measure.....	74
Auto trigger.....	131	Delay trigger.....	138
Automatic measurement		Deskew.....	127
display all.....	78	Dimensions	
gated mode	77	diagram.....	209
individual mode.....	75	specification.....	207
overview.....	72	Display	
remove measurement	76	diagram.....	29
Auto-range	65	specification.....	206
exception	66	Disposal instructions.....	9
Autoset.....	64	Dots.....	110
effect on channel.....	64	Duty cycle measure	73
exception	65	Edge Trigger.....	136
Average voltage measure.....	73	EN61010	
Bandwidth filter	124	measurement category	7
Blackman window.....	87	pollution degree.....	8
Built-in help.....	59	Environment	
Buzzer	148	safety instruction	8
Calibration, accuracy resolution	194	Equivalent time sampling.....	108
Caution symbol	5	Erase memory	147
Channel.....	63	Ethernet	
status indicator	31	interface.....	188
Cleaning the instrument.....	8	Expand by ground/center	125
Control panel function		External trigger	131
specification	206	input terminal	26
Convention		specification.....	205
menu tree	43	Falling time measure	73
Conventions	37	FAQ	199
Coupling mode.....	122	FFT.....	89
Cursor		horizontal cursor.....	81

Overview	86	Math.....	86
vertical cursor	84	basic	87
File		FFT	89
create folder.....	176	Memory bar	
delete.....	179	indicator	30
rename	177	Menu on/off.....	115
File navigation.....	174	Miscellaneous	
File path	175	specification.....	207
Firmware version.....	147	Model difference	15
First time use	34	Normal trigger.....	131
Frequency measure	73	NTSC	133
Front panel diagram.....	20	On-screen help	59
Go-NoGo.....	93	Optional software	
circuit diagram.....	97	activation.....	197
timing.....	96	Overshoot voltage measure	73
GPIO		Package contents	18
interface	191	PAL	133
Ground		PC software download.....	192
coupling.....	123	Peak voltage measure.....	72
symbol.....	5	Persistence	111
terminal.....	26	Power Analysis	98
Hamming window	87	overview	98
Hanning window.....	86	Power measurements	
High voltage measure	73	specification.....	206
Holdoff.....	104, 135	Power on/off	
Horizontal		safety instruction.....	8
basic operation.....	67	Power source	
position	116	specification.....	207
scale.....	117	Preshoot voltage measure.....	73
specification.....	205	Printing	
Image file format.....	152	connection.....	181
Impedance	123	ink saver.....	183
Initialization	34	print key	182
Input frequency indicator.....	30	Printing.....	181
Intensity	111	Probe	
color.....	113	attenuation level.....	126
gray	113	attenuation type	126
Interface	186	deskew	127
specification.....	206	package list	18
Invert waveform	123	Probe compensation	195
Keys overview.....	22	Pulse runt trigger	142
Labels	156	Pulse time measure.....	73
Language selection	146	Pulse width trigger	139
List of features.....	16	Real time sampling	108
Logic trigger	144	Rear panel diagram	27
Low voltage measure	73		

Recall	165	Tilt stand	32
default setup	165	Time setting	148
reference	170	indicator	30
setup	167, 168	Trigger	129
waveform	167	delay	138
Rectangular window	87	edge	136
Reduce menu	39	holdoff	135
Remote control	185	indicator	30
interface configuration	186	Logic	144
Rising time measure	73	mode	136
Roll mode	118	parameters	131
RS-232C		pulse runt	142
interface	187	pulse width	139
Run/stop	66	single trigger with run/stop	67
Run/Stop	115	specification	204
horizontal position	116	status indicator	31
Horizontal scale	117	video	141
Save	158	UK power cord	10
image	159	USB	
print key	160	remote control interface	186
setup	163	Vectors	110
waveform	162	Vertical	121
SECAM	133	accuracy calibration	194
Serial bus		basic operation	69
overview	99	position	121
Serial Bus	99	scale	122
Serial number	147	specification	204
Service operation		Video trigger	141
about disassembly	7	Warning symbol	5
Setup		Waveform	
default contents	57	data contents	153
file format	154	file contents	153
Single trigger mode	131	how to recall	167
with run/stop	67	how to save	162
Software activation	197	invert waveform	123
Specifications	203	roll mode	118
Split Window		zoom mode	119
operation	70	Waveform color	29
reference position	71	Waveform file format	152
Spreadsheet file format	153	XY	
Stop icon	66	specification	205
System information	146	Zoom waveform	119