



Output Feeder Monitor Set MEG71

User manual



Output feeder monitor set MEg71

1/ INTRODUCTION

The MEg71 output feeder monitor set measures voltages, currents, powers and energies of a three-phase output feeder with a LV fuse fail or a fuse disconnecter rail of a cabinet or a station; it registers both voltage phenomena and short-circuit currents and signalizes the status of fuses of the LV rail. It records these data into a non-volatile data memory, displays them on its indication elements, signalizes them with its contact and when it is on-line connected, it transfers the data to higher-level information systems.

The MEg71 output feeder monitor set comprises the MEg71 monitor unit and the MEgML71 measuring rail. The MEg71 monitor unit is available in two versions according to the space available above the LV rails. The slim version MEg71S with indicating LEDs is designed for cabinets with a small space above the LV rails and the version MEg71D with a display is to be used when the space above the LV rails is sufficient.

The MEg71 monitor set measures voltages at the feeder (behind the fuses) and at the busbars (in front of the fuses) and determines the status of the fuses from them. It measures currents in two ranges. It measures in the measuring range up to 1.2 multiple of the rated current of the installed fuses of the LV feeder and the short-circuit currents to the tenfold rated current at least. The MEg71 output feeder monitor set is supplied by a DC supply voltage with a rated value of 12 V. It has a RS485 serial interface with MODBUS protocol or a more efficient proprietary protocol for local and remote communication.

The MEgML71 measuring rail is provided with current sensors with a high instrument security factor and electronic protection when their secondary circuits are disconnected. The rated values of their secondary currents are reduced in order to reduce losses. It is to be installed between busbars and the LV rail of the cabinet. It is characterized by its low height, therefore it can be installed also additionally into already operating LV cabinets. The MEgML71 measuring rail is designed for the most demanding working conditions with the overvoltage category CAT IV.

The monitor unit in both versions can be reconnected to various MEgML71 measuring rails also during operation with maintaining the specified measuring accuracy and without any risk of failure of the measuring rail due to the disconnection of secondary circuits of its current sensors.

2/ TECHNICAL PARAMETERS

Reference conditions

$U_{\text{supply}} = 12 V_{\text{DC}}$, ambient temperature = 20 °C, relative humidity = 40 % to 70 %
 $f = 50.0 \text{ Hz}$, measured voltages and currents with the same frequency constitute a three-phase system

MEg71D or MEg71S Output feeder monitor unit

Feeder voltage, voltage of busbars (direct measurement, CATIV/300 V)

Rated value U_{nom} : $230 V_{\text{AC}}$
Measuring range: $5\% \text{ to } 130\% U_{\text{nom}}$
Measuring accuracy: $0.2\% U_{\text{nom}} + 0.1\% \text{ M.V. } ^1$
Maximum voltage: 300 V

Measured currents (direct measurement)

Rated value $I_{\text{nom}} ^2$: $80 A_{\text{AC}}, 160 A_{\text{AC}}, 320 A_{\text{AC}}, 640 A_{\text{AC}}$
Measuring range: $2\% \text{ to } 120\% I_{\text{nom}}$
Measuring accuracy, $I_{\text{nomM}} = 80 \text{ A}, 160 \text{ A}$: $0.5\% I_{\text{nomM}} + 0.1\% \text{ M.V. including sensor}$
 $I_{\text{nomM}} = 320 \text{ A}, 640 \text{ A}$: $1.0\% I_{\text{nomM}} + 0.1\% \text{ M.V. including sensor}$

Active power

Rated value P_{nom} : $U_{\text{nom}} \cdot I_{\text{nomM}}$
Measuring range: $0.8 U_{\text{nom}} \leq U \leq 1.3 U_{\text{nom}}$
 $0.02 I_{\text{nomM}} \leq U \leq 1.2 I_{\text{nomM}}$
 $\cos \varphi \geq 0.5$
Measuring accuracy, $I_{\text{nomM}} = 80 \text{ A}, 160 \text{ A}$: $1.0\% P_{\text{nom}}$, including sensor
 $I_{\text{nomM}} = 320 \text{ A}, 640 \text{ A}$: $1.5\% P_{\text{nom}}$, including sensor

Reactive power

Rated value Q_{nom} : $U_{\text{nom}} \cdot I_{\text{nomM}}$
Measuring range: $0.8 U_{\text{nom}} \leq U \leq 1.3 U_{\text{nom}}$
 $0.02 I_{\text{nomM}} \leq U \leq 1.2 I_{\text{nomM}}$
 $\cos \varphi \leq 0.707$
Measuring accuracy, $I_{\text{nomM}} = 80 \text{ A}, 160 \text{ A}$: $1.0\% Q_{\text{nom}}$, including sensor
 $I_{\text{nomM}} = 320 \text{ A}, 640 \text{ A}$: $1.5\% Q_{\text{nom}}$, including sensor

Active energy

Measuring range:	$0.8 U_{nom} \leq U \leq 1.3 U_{nom}$ $0.02 I_{nomM} \leq U \leq 1.2 I_{nomM}$ $\cos \phi_L \geq 0.5$ $\cos \phi_C \geq 0.8$
Measuring accuracy:	class B, including sensor

Voltage events ^{3), 4)}

Rated value U_{nom} :	$230 V_{AC}$
Measuring range $U_{RMS1/2}$:	$0.05 U_{nom} \leq U \leq 1.3 U_{nom}$
Measuring accuracy $U_{RMS1/2}$ ⁵⁾ :	$0.5 \% U_{nom} + 0.1 \% M.V.$
Measuring range T	$0.02 \text{ sec} < T \leq 60 \text{ sec}$
Measuring accuracy T ⁵⁾ :	$\pm 20 \text{ msec}$

Short-circuit currents I_Z ^{2), 6)}

Rated value I_{nomZ} :	$2000 A_{AC}, 6000 A_{AC}$
Measuring range I_Z :	$1.2 I_{nomM}$ to I_{nomZ}
Measuring accuracy I_Z :	$10 \% M.V.$ including sensor

Internal time

Accuracy:	$1.0 \text{ sec} / 24 \text{ hrs.}$ at ambient reference temperature
Accuracy at synchronisation of network $f^{7)}$:	network T $\pm 1 \text{ sec}$
PLL (Phase Locked Loop) frequency range ⁸⁾ :	42.5 Hz to 57.5 Hz
Overload capacity of current inputs:	$2 I_{nomM} / 1 \text{ min}, 10 I_{nomM} / 1.5 \text{ sec}$

General data

Data memory:	$4 \text{ MB} + 4 \text{ MB}$ (flash)
Data memory organization:	circular
Serial interface:	RS485, 115.2 kbit/sec
Recording interval:	from 1 sec to 15 minutes , set by SW
Maximum number of recorded events:	1024
Maximum length of recorded event course ^{9), 10)} :	$125 \text{ periods}, 250 \text{ values } U_{RMS1/2}$
Fixed pre-trigger:	10 periods
Fixed post-trigger:	20 periods

Power supply

Rated voltage:	12 V _{DC}
Supply voltage range:	8 V _{DC} to 15 V _{DC}
Supply current at voltage 12 V _{DC} :	MEg71D = 85 mA, MEg71S = 55 mA
at voltage 15 V _{DC} :	MEg71D = 100 mA, MEg71S = 75 mA

Unit construction

Version MEg71S:	97 × 107 × 17 mm
Version MEg71D:	97 × 107 × 40.5 mm
Weight of MEg71S:	110 g
Weight of MEg71D:	140 g
Input-output connector:	type CAN25V

Operating data of the unit

Output feeder monitor unit MEg71D and MEg71S	
Working temperature:	-20 °C to +60 °C
Relative humidity:	20 % to 90 % at 40 °C
Storage temperature:	-25 °C to +80 °C
Protection rating:	IP20 – accessible parts, IP00 – inaccessible parts)
Pollution degree:	2
Safety:	EN 61010-1:2010, EN 61010-2-030:2010

Electromagnetic compatibility

Electrical fast transient/burst immunity test:	EN 61000-4-4:2004
Surge immunity test:	EN 61000-4-5:2006
Immunity to conducted disturbances, induced by radio-frequency fields:	EN 61000-4-6:2009
Radiated emissions in the frequency band 30 MHz–1 GHz:	EN 55011:2009 Art. 6.2.1
Interference voltages on supply terminals:	EN 55011:2009 Art. 6.2.2
Electric discharges (ESD):	EN 61000-4-2:2009
Radiated radio-frequency electromagnetic field:	EN 61000-4-3:2006
Voltage dips, short interruptions and voltage variations:	EN 61000-4-11:2004

MEgML71 Measuring rail

Current transformer

Rated primary current ¹¹⁾: 250 A_{AC}, 400 A_{AC}, 630 A_{AC}

Security factor: 10

Rated short-time (thermal) current: 20 kA for 1 sec

Maximum voltage between
current inputs: 520 V_{AC}

Rated frequency: 50 Hz

Frequency range: 40 Hz to 60 Hz

The secondary circuit of the current transformer can be permanently open.

Rated voltage value: 230 V_{AC}

Input resistance of voltage inputs
of three-phase front-end resistor
(feeder voltage, voltage of busbars): 3.37 MΩ ± 1 %

Maximum input phase voltage: 300 V_{AC}

Voltage drop on coupling of measuring rail ¹²⁾

at I_{nom} = 640 A: < 10 mV

at I_{max} = 6400 A: < 100 mV

Dimensions ¹³⁾: 540 × 79 × 26 mm (without three-phase front-end resistor)
560 × 79 × 26 mm (with three-phase front-end resistor)

Centre-to-centre distance of holes: 185 mm

Fastening screws ¹⁴⁾: M12×40 hex. h., M12×65 hex. h.
flat washer 12, spring washer 12

Specified tightening moment
of attaching screws: 28 Nm

Maximum cross-section of wires
of terminal blocks X3, X4 and X5: 1.5 mm²

Temperature range: -40 °C, +80 °C,
temperature of busbars temporarily up to 100 °C

Protection rating: IP 00

Maximum humidity: 95 %

Overvoltage category: CAT IV / 300 V

Notes:

- 1) M.V. – measured value.
- 2) Only one of these values. It is derived from the rated fuse current set on the DIP switch.
- 3) If uninterruptible power supply is provided.
- 4) It registers events with the duration T longer than 1 sec with characteristics specified in EN 50160, ed. 3, i.e. with the residual and maximum voltage and the duration of the voltage phenomenon.
- 5) It complies with Class S of EN 61000-4-30, ed. 2.
- 6) It is derived from the rated fuse current set on the DIP switch. The range of the short-circuit current 2000 A is applicable to the measuring range 80 A and 160 A and the range the short-circuit current 6000 A is applicable to the measuring range 320 A and 640 A.
The maximum duration of the short-circuit current is 1.5 sec.
- 7) If phase lock loop is locked.
- 8) When a frequency is out of the frequency range or the voltage of the L1 busbar is less than 10 V, the frequency will be set to 50.00 Hz.
- 9) All the measured voltages and all the measured currents in values of $U_{\text{RMS1/2}}$ and $I_{\text{RMS1/2}}$ are recorded.
- 10) When events are longer than the maximum length of the record, extreme values in accordance with the EN 50160, ed. 3 are recorded and evaluated after the pre-trigger and the initial run, and after the event is ended, the values are recorded over the period of the post-trigger.
- 11) Only one of these values; as specified in the order.
- 12) For the specified tightening torque of the attaching screws.
- 13) For details see Fig. 1.
- 14) According to versions of the LV busbars, see Fig. 8a and Fig. 8b.

3/ DESCRIPTION OF THE WIRING AND FUNCTION OF THE MEg71 OUTPUT FEEDER MONITOR SET

The MEg71 output feeder monitor set consists of the monitor unit either in the version MEg71D with a display or in the slim version MEg71S, which is to be attached to the MEgML71 measuring rail. Two three-phase voltages and one phase currents are converted to LV signals via impregnated sensors and via a 3-phase front end resistor, which are located on the measuring rail. The phase currents and 3-phase voltages of the busbars are measured via three sensors – in front of the fuse. The 3-phase voltage at the LV feeder is measured via an optionally installed 3-phase front-end resistor – behind the fuse.

The sensors on the measuring rail are ring-type and are designed for accurate current measuring up to 1.2 multiple of the current of the fuse rails with the rated currents 250 A, 400 A and 630 A. Besides, the toroids have a high security factor, which also enables to measure courses of short-circuit currents. The sensor is provided with low-loss protections, which protect the toroid windings from overvoltage effects during the disconnection of the measuring current circuits. As fuses ranging between 40 A and 630 A are usually used on the LV feeders, according to feeder nominal value of current (marked as IR), this nominal value can be set on the DIP switch located in the termination of the CANNON connector of the measuring rail. There is a memory in the termination of the CANNON connector, which contains also other information related to the measured LV feeder.

After the output feeder monitor is connected to the CANNON connector of the measuring rail, the processor of the unit reads the data and accordingly modifies parameters of the measurement and generates the heading of the new data file. The CANNON connector is located in the termination at the end of the folded flat cable so that the MEgML71 measuring rails can be installed during production of the LV cabinets and the monitor units can be installed additionally after installation of power units, and also for the reason of a possible reconnection of the output feeder monitor unit to various LV feeders. The connector is connected using this cable in front of the panel of the LV cabinet. The CANNON connector is provided with a bolted plastic housing with arms, which protects the connector from falling into the area with live parts behind the panel of the LV cabinet. The MEg71D and MEg71S monitor unit is to be inserted into a set of guide rails with a lock, which is to be assembled according to the position of the installed measuring rails. The set of guide rails is to be inserted into a longitudinal cut made in the panel of the LV cabinet with the fuse rails.

There is a four-pole socket of the connector located in a plastic housing at the lower end of the measuring rail on a round four-core cable that is voltage-rated for the environment of the LV cabinet for connecting the DC supply voltage to the output feeder monitor and for its RS485 serial communication with a local or a remote information system. The serial communication is used both for reading the measured data and parametrizing the

measurement and for updating the control program of the processor of the output feeder monitor. It enables both remote and local update of measuring methods also when the output feeder monitor is installed.

Three separate highly flexible measuring voltage wires with double insulation and terminated with eyes run from the three-phase front-end resistor optionally connected on the measuring rail; the eyes are to be screwed under the screws of modified lugs of the V-clamps of the fuse or disconnector rails.

The side of the MEG71 measuring rail is marked, which is to be put on the LV busbars, and the side, to which the fuse or disconnector rail is to be applied. It is both for maintaining the correct direction of the measured current and for safety of installation.

The MEG71 output feeder monitor set consists of the monitor unit either in the version MEG71D with a display or in the slim version MEG71S, which is to be attached to the measuring rail MEGML71. The monitor unit measures the three-phase voltage at the feeder of the LV rail and the three-phase voltage of the busbars via front-end resistors with the same values. Installation of the three-phase front end resistor on the measuring rail for measuring the voltage at the feeder is used for determining the status of fuses if it is necessary to measure the differential voltage at the LV feeder and the voltage at the busbars. The three-phase front-end resistors are integrated in the phase current sensors attached to the MEGML71 measuring rail.

The phase current transducers contain ring-type current transformers, which are designed for accurate measurements of currents in the range of the measured currents and also have a high instrument security factor that enables to measure also short-circuit currents. The secondary currents of the current transformers are measured by the monitor unit in two ranges, in the range of the measured currents and in the range of the short-circuit currents.

4/ PRINCIPLE OF MEASUREMENT

The sampling of signals of both of the three-phase voltages and of the three-phase current from the MEgML71 measuring rail is performed in the MEg71 monitor unit at a frequency that is 128 times higher than the frequency of the L1 terminal voltage. The basis for the values recorded by the recorder and the electrometer function are true RMS values calculated from the samples per 10 periods. Average RMS values are calculated from them for a specified recording interval and extreme 10-period values of voltage, current and active power are evaluated, which are saved in a non-volatile 4 MB data memory. The status of the fuses of the LV rail is evaluated from the measured voltages in front of and behind the fuses and from the measured currents. After the individual recording interval is completed, the entries in the six energy counters are recorded in the data memory of the monitor unit. They are counters of the consumption and supply of active power, of the consumption and supply of inductive reactive power and of the consumption and supply of capacitive reactive power. It is possible to evaluate the energy consumption rate for any given period from these values without restricting the number of tariffs.

The events include short circuits, power outages and voltage phenomena in accordance with EN 50160, ed. 3, i.e. voltage drops, increases and interruptions. These events are recorded in a non-volatile data memory. The voltage values $U_{\text{RMS1/2}}$ and current values $I_{\text{RMS1/2}}$ of the measured voltages and currents are calculated continuously and without any interruptions in order to evaluate the voltage phenomena and short-circuit currents. As soon as any of the three-phase voltages or any of the three-phase currents exceeds its preset value, the incidence of a voltage phenomenon or of a short-circuit current is detected. It means above the limit set by the parameterization program in $\% I_{\text{nom}}$ of the installed fuses in regard to a short-circuit current, below $90\% U_{\text{nom}}$ in regard to a voltage drop, over $110\% \text{ nom}$ in regard to a voltage increase and when all of the three measured voltages drop below $5\% U_{\text{nom}}$ in regard to a voltage interruption according to EN 50160, ed. 3. When a voltage phenomenon or a short-circuit current occurs, its starting time is recorded in a non-volatile data memory together with the course of all values $U_{\text{RMS1/2}}$ and $I_{\text{RMS1/2}}$ of the measured voltages and currents of the pre-trigger in the duration of 10 periods and this recording continues up to the end of the voltage phenomenon or the short-circuit current, but not longer than for 125 periods (2.5 sec). If a voltage phenomenon or a short-circuit current lasts longer than the longest time of the record, extreme values are evaluated from the subsequent $U_{\text{RMS1/2}}$ and $I_{\text{RMS1/2}}$ values, which are written into the data memory including the time of termination. The time of termination of a voltage phenomenon occurs when the $U_{\text{RMS1/2}}$ voltage returns above $(90+2)\% U_{\text{nom}}$ during a voltage drop or drops below $(110-2)\% U_{\text{nom}}$ during an overvoltage or at least one of the voltages rises above $5\% U_{\text{nom}}$ during a voltage interruption. The short-circuit current ends when values of all phase currents drop below a preset limit. The course of all measured voltages

and currents are always recorded for the next 20 periods after the time of termination – i.e. for the post-trigger period.

The above-mentioned procedure for measuring short-circuit currents and voltage phenomena in the output feeder monitor set is conditioned by an existing supply voltage. The voltage measured at the MEG71 output feeder monitor set is usually also the voltage, which supplies the $12 V_{DC}$ power supply; therefore it is advisable to use an uninterruptible power supply for supplying the MEG71 output feeder monitor set. In the event of a power failure, the start and end time of the power failure are recorded into the data memory of the MEG71 output feeder monitor unit with a degree of accuracy in the order of seconds. When the power is restored, first the processor checks the hardware for function, reads technological information from the connected measuring rail and then starts the measurement. The recorded data include also information at the beginning of each of the data files regarding the measuring range, identification of the measured feeder and other technological and time data for unique assignment of the measured data to the measured LV feeder.

5/ DISPLAY, DISPLAY CONTROL AND MEASURING RANGE SETTING AND RECORDING

The RMS values calculated from four previous 10-period values are used for displaying or indicating the measured values. Therefore the display of the measured values is updated every 0.8 sec.

The slim version of the MEG71S monitor unit uses LEDs for indicating voltages and phase currents and it is not equipped with any control element for controlling the indication. If all of the three voltages that are measured and recorded are within the tolerance set by the parameterization program – usually $U_{nom} \pm 10\% U_{nom}$, – then the green LED U lights permanently. If any of the three measured and recorded voltages is outside the tolerance, the LED U lights oscillating. If all of the three voltages drop below $5\% U_{nom}$ and the power supply is uninterruptible, the LED does not light.

Three yellow LEDs are used for indicating each of the I1, I2, I3 currents and one red LED for indicating the status of the corresponding LV fuse. The current indication is derived from the rated value of the currents of the fuses installed on the LV rail, which is set on the six-pole DIP switch that is located in the housing of the CANNON connector of the measuring rail.

The first three yellow LEDs indicate the size of the current of the corresponding phase. When the measured current increases to $1/3 I_{nom}$ of the installed fuse, the first yellow LED on the left starts flashing; when the current is increasing, the duration of the light pulse gets longer and when the current reaches $1/3 I_{nom}$, the first LED lights permanently.

When the current is increasing more, the second yellow LED starts flashing beside the first yellow permanently lighting LED and when the current is $\frac{2}{3}I_{nom}$, both of them light permanently. All of the three yellow LEDs light permanently when the current of the corresponding phase reaches the value of I_{nom} . When the current increases above $1.05I_{nom}$ of the installed fuse, the last red LED starts lighting permanently indicating that the rated current is exceeded.

An open fuse is indicated by the corresponding last red LED that lights oscillating, while the first three yellow LEDs do not light.

Both versions of the monitor unit, MEg71S and MEg71D, have a yellow LED **RUN** on the panel, which starts lighting permanently, after the power supply is connected and the HW check was successful. If the LED **RUN** does not light, there is a probability of a power failure.

The MEg71D monitor unit uses an 8-digit alphanumeric backlit LED display for displaying the measured values and it has one control button. The voltage of the first, second and third phase, the current of the first, second and third phase and the sum of the active and reactive power of the feeder cycle on the display in the basic display mode. The display time of the individual values is 5 sec and so the entire display cycle lasts 40 sec. The display backlighting can be enabled in low-light conditions by short pressing the control button in the cycling mode and can be disabled by another short pressing the button or it goes out automatically after 1 minute.

The cycling mode can be interrupted by long 1-second pressing; then the unit changes to the scrolling mode and the backlighting lights up at the same time and the display gradually scrolls to the next displayed variables of the advanced displaying. The selected value is displayed until the button is pressed shortly again or the display returns to the cycling mode without the backlighting after 1 minute. The repeated short pressings can be substituted by a permanent pressing of the control button in the scrolling mode in order to change the displayed values by about 0.5 sec in the following order according to Tab. 1 starting with the value that is currently displayed.

The MEg71 has two ranges, namely a measuring range and a short-circuit recording range. The measuring range has four levels, namely 80 A, 160 A, 320 A and 640 A and the short-circuit recording range has two levels, namely 2000 A and 6000 A. Both the measuring range and the short-circuit recording range is derived from the rated value of the fuses installed in the fuse or disconnector rail. This value must be transmitted to the slide six-pole DIP switch located in the termination of the CANNON connector of the rail.

Tab. 1: Scrolling of the displayed values on the display of the MEg71D monitor

Step	Name	Advanced display	Meaning
1	phase voltage L1	1 2 2 8 , 6 V	U_{L1} in V is in tolerance
2	phase voltage L2	2 □ 2 6 0 , 2 V	U_{L2} in V is above tolerance
3	phase voltage L3	3 □ 2 0 0 , 5 V	U_{L3} in V is below tolerance
4	delta voltage L1	1 2 3 9 8 V	$U_{L1, L2}$ in V is in tolerance
5	delta voltage L2	2 3 □ 4 5 0 V	$U_{L2, L3}$ in V is above limit
6	delta voltage L3	3 1 □ 3 5 0 V	$U_{L3, L1}$ in V is below limit
7	phase current L1	1 8 8 , 6 A	I_{L1} in A is below I_{nom} of fuse
8	phase current L2	2 □ 1 0 2 , 1 A	I_{L2} in A is above I_{nom} of fuse
9	phase current L3	3 9 5 , 6 A	I_{L3} in A is below I_{nom} of fuse
10	active power L1	1 + 1 2 8 k W	P_{L1} in kW; consumption
11	active power L2	2 - 9 5 , 4 k W	P_{L2} in kW; delivery
12	active power L3	3 + 1 , 4 5 k W	P_{L3} in kW; consumption
13	sum of active powers	Σ + 2 2 , 8 k W	P_{Feeder} in kW; consumption
14	reactive power L1	1 + L 1 2 8 k r	Q_{L1} in kVAr, consumption, inductive
15	reactive power L2	2 - C 7 4 k r	Q_{L2} in kVAr, delivery, capacitive
16	reactive power L3	3 + L 2 , 8 k r	Q_{L3} in kVAr, consumption, inductive
17	sum of reactive powers	Σ - C 1 5 k r	Q_{Feeder} in kVAr, consumption, capacitive
18	power factor L1	φ 1 + L 1 , 0 0	power factor L1, consumption, resistive
19	power factor L2	φ 2 - C 0 , 9 8	power factor L2, consumption, capacitive
20	power factor L3	φ 3 + L 0 , 7 4	power factor L3, delivery, inductive
21	state of fuses	F u - X ?	
22	range of current	R l 2 2 4 A	Fuse value=224 A

Notes: Symbols are used for displaying the **status of fuses** where the symbol **-** means a “good fuse”, the symbol **X** means a “blown fuse” and the symbol **?** means that “the status of the fuse has not been yet recognised”.

Range of current usually corresponding to nominal current of the feeder and this value should be identical with rated current of fuses.

text continues on page 25

ILLUSTRATED APPENDIX

Fig. 1: MEgML71 measuring rail set

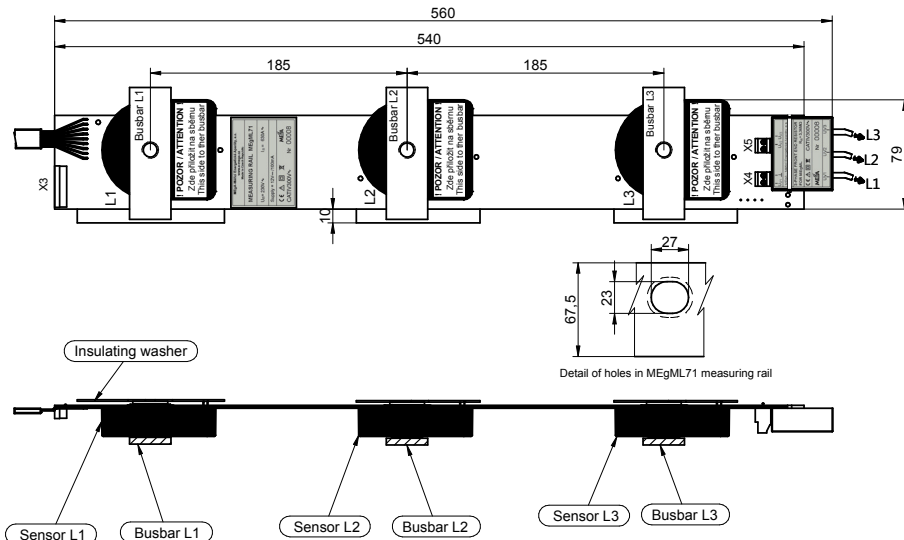

Fig. 2: Rating plate of the MEgML71 measuring rail

MEGA-Měřicí Energetické Aparáty, a.s. www.e-mega.cz Made in Czech Republic	
MEASURING RAIL MEgML71	
$U_n = 230V \sim$	$I_n = 630A \sim$
Supply = 12V---/100mA	
CE ▲ □ ✕	MEGA Nr 00008
CAtIV300V~	

Fig. 3: Connecting the signalling contacts of the switch rail to the X3 connector of the MEgML71

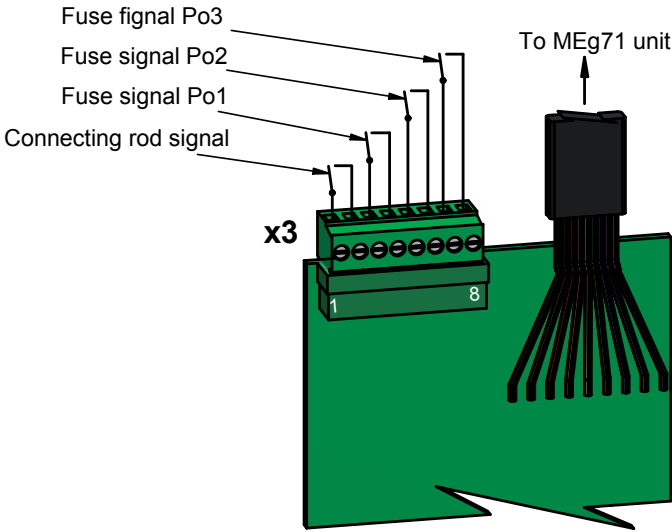

Fig. 4: Detail of the upper end of the MEgML71 measuring rail

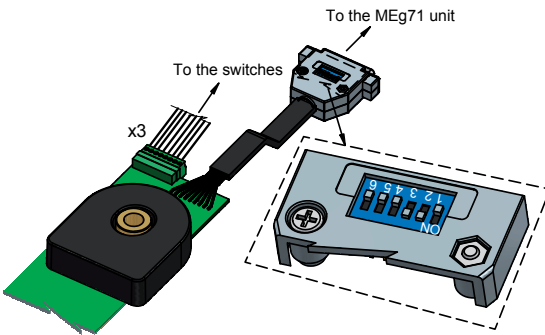

Fig. 5: CANNON connector with DIP switches and a housing with arms

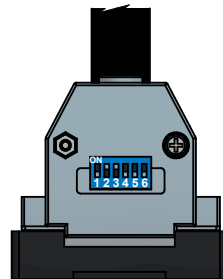

Fig. 6: Detail of the lower end of the MEgML71 measuring rail

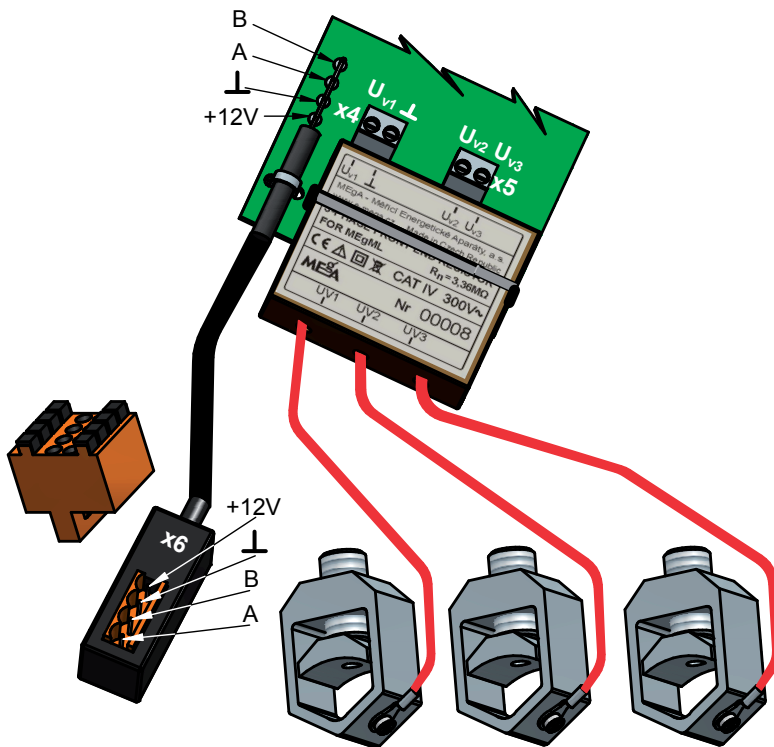

Fig. 7: Rating plate of the three-phase front-end resistor





U_{V1}	\perp	U_{V2}	U_{V3}
MEgA - Měřicí Energetické Aparáty, a.s. www.e-mega.cz Made in Czech Republic			
3-PHASE FRONT END RESISTOR			
FOR MEgML		$R_n = 3,36M\Omega$	
   		CATIV300V~	
MEgA		Nr 00008	
$UV1$	$UV2$	$UV3$	

Fig.8a: Detail of connection of the busbar with a threaded insert to the contact of the LV rail

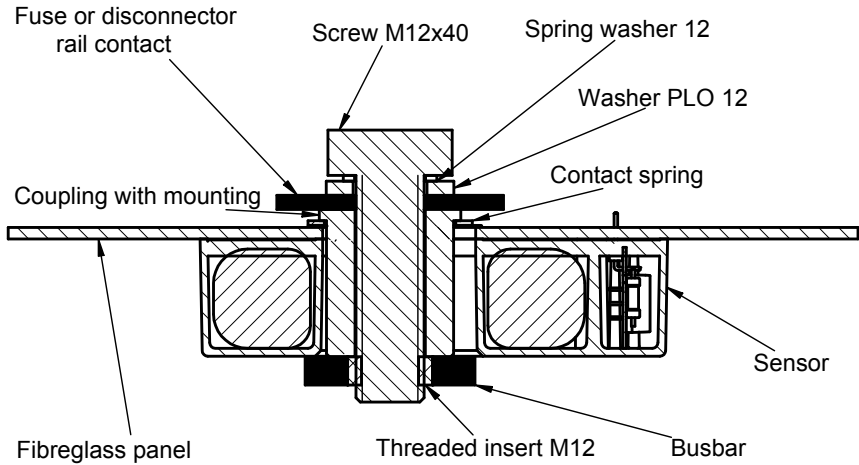

Fig.8b: Detail of connection of the busbar without a threaded insert to the contact of the LV rail

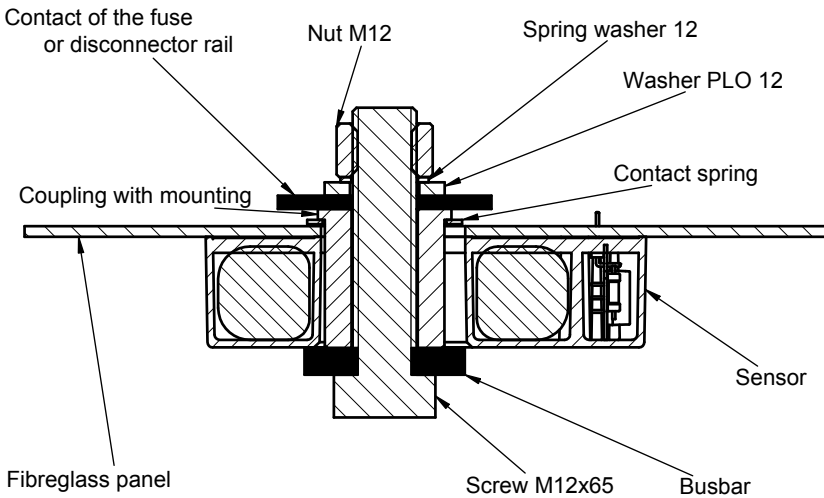

Fig. 9: Dimensions of the slim version of the MEg71S monitor unit

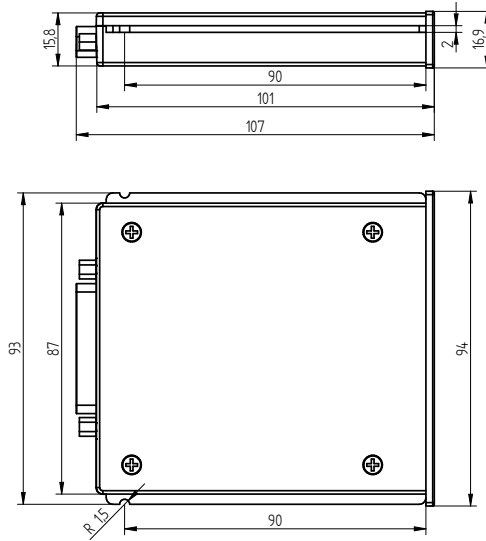

Fig. 10: Dimensions of the MEg71D monitor unit with a display

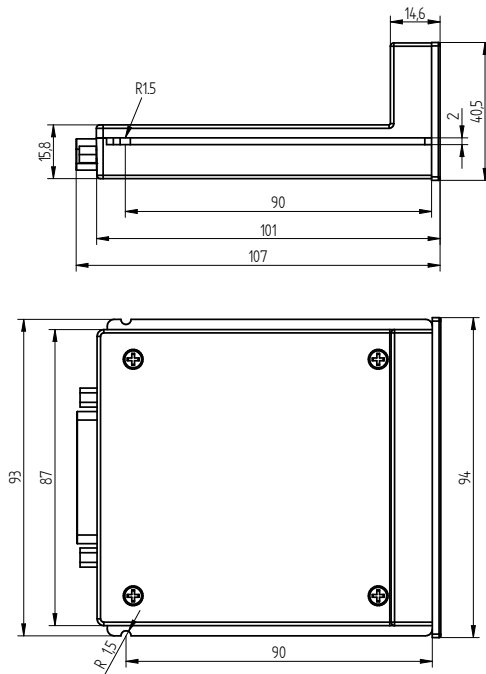

Fig. 11: Rating plates of the MEg71D and MEg71S monitor units

MEgA-Měřicí Energetické Aparáty, a.s. www.e-mega.cz Made in Czech Republic	
OUTPUT FEEDER MONITOR	MEg71D
$U_n = 230V \sim$	$U_{max} = 300V \sim$
Supply: $U_n = 12V \text{ ---}$	$I_n = 100mA$
MEGA Nr 00008	

MEgA-Měřicí Energetické Aparáty, a.s. www.e-mega.cz Made in Czech Republic	
OUTPUT FEEDER MONITOR	MEg71S
$U_n = 230V \sim$	$U_{max} = 300V \sim$
Supply: $U_n = 12V \text{ ---}$	$I_n = 60mA$
MEGA Nr 00009	

Fig. 12: Construction of the guide rail set of the MEg71D and MEg71S monitor units

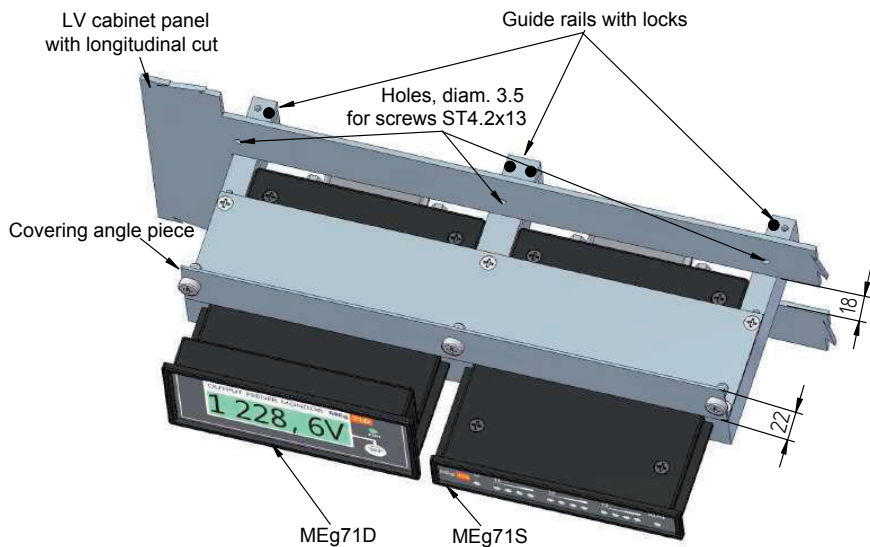

Fig. 13: Wiring of the supply and communication circuits of the MEG71 output feeder monitor sets in the LV cabinet

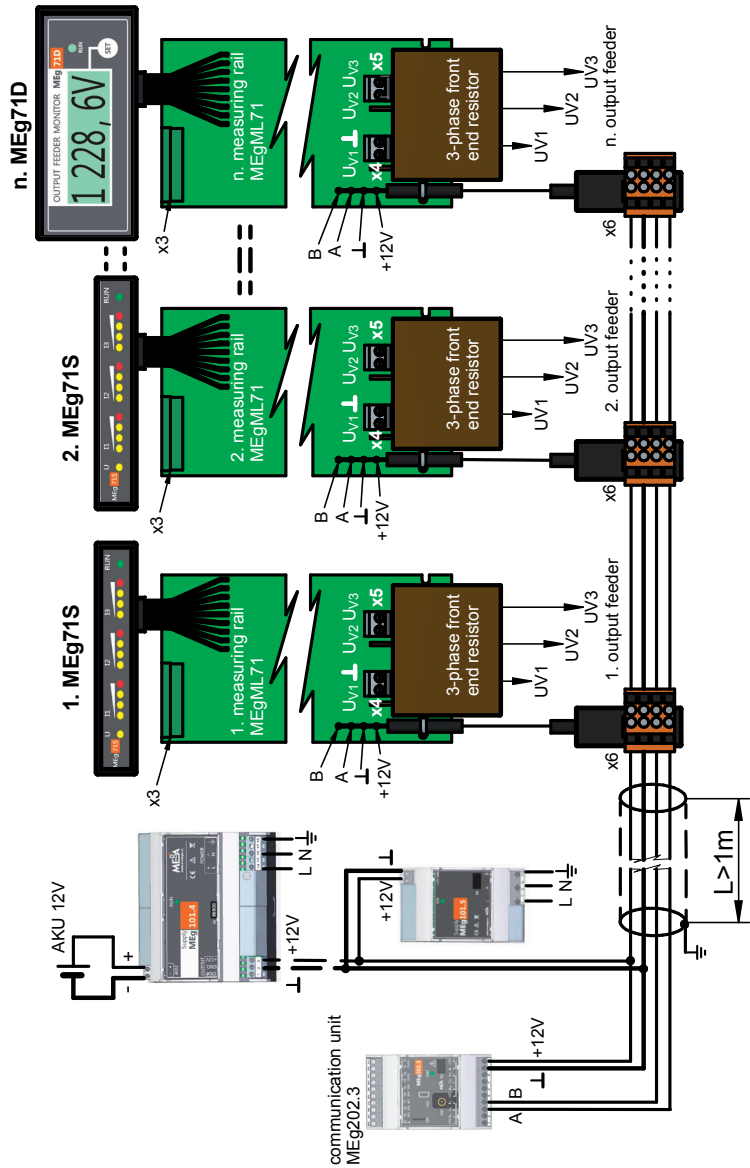

Fig. 14a: Layout of components of the MEgML71 measuring rail on the LV busbar with a threaded insert

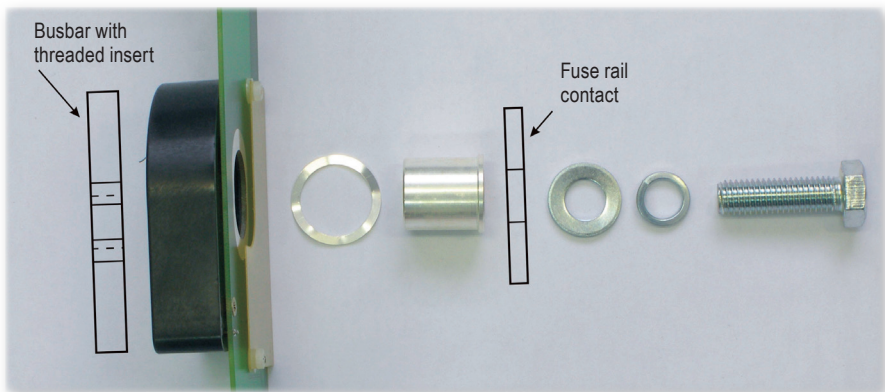

Fig. 14b: Layout of components of the MEgML71 measuring rail on the LV busbar without a threaded insert

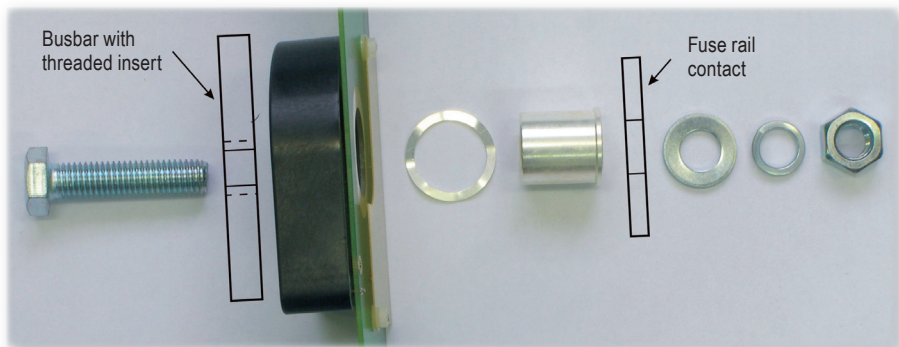

Fig. 15: Dimensions of the MEg202.3 communication unit and MEg101.4, MEg101.5 power supplies

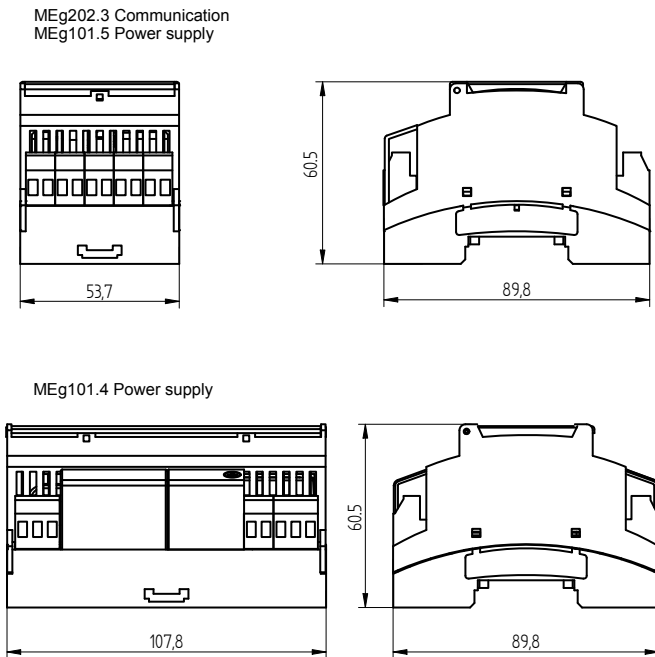

Fig. 16: Example of displaying of a selected event by the Merci application

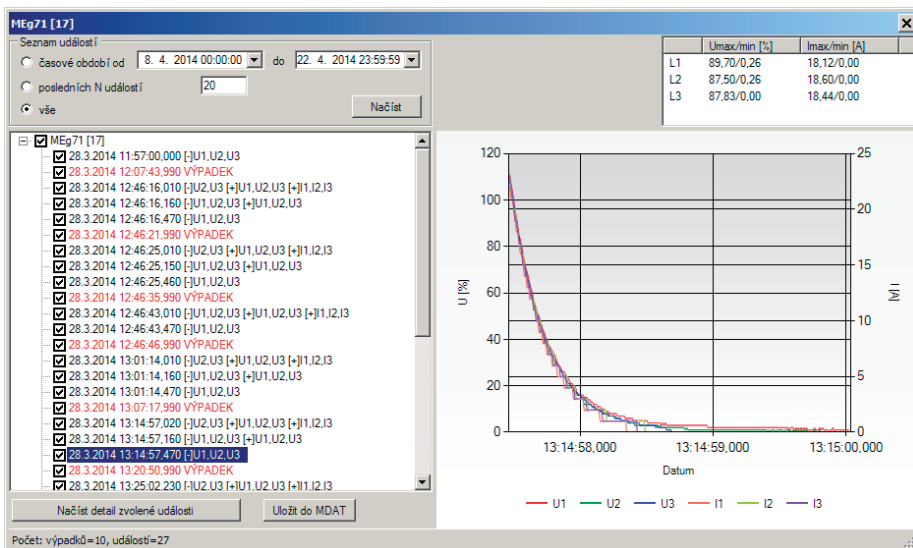
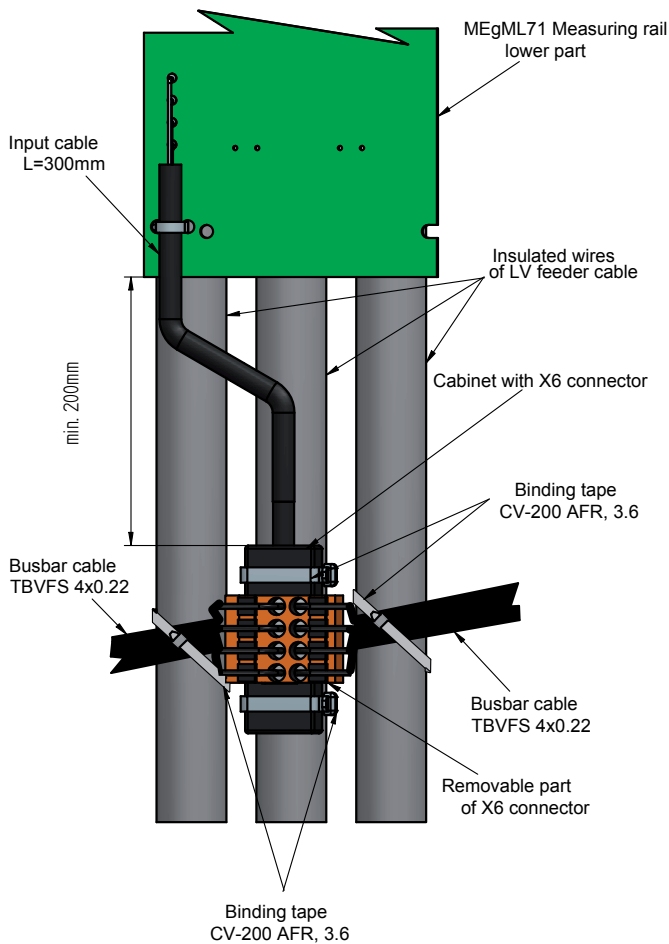

Fig.17: Attachment of the X6 connector and busbar cables to insulated cable parts of a LV feeder



It is assumed that the following PN fuse-links are used for the fuse or disconnector rails with the rated value of 250 A, 400 A and 630 A:

40 A, 50 A, 63 A, 80 A, 100 A, 125 A, 160 A, 200 A, 224 A, 250 A, 315 A, 350 A, 400 A, 500 A and 630 A. The six-pole slide DIP switch located in the termination of the CAN-NON connector of the measuring rail is to be set according to the fuse values; see Tab. 2.

Tab. 2: Setting of DIP switch poles according to fuse values

Fuse value [A]	DIP switch poles					
	1	2	3	4	5	6
40	-	-	ON	-	-	-
50	ON	-	ON	-	-	-
63	-	ON	ON	-	-	-
80	-	-	-	ON	-	-
100	-	ON	-	ON	-	-
125	-	-	ON	ON	-	-
160	-	-	-	-	ON	-
200	-	-	ON	-	ON	-
224	-	ON	ON	-	ON	-
250	ON	-	-	ON	ON	-
315	ON	ON	ON	ON	ON	-
350	ON	ON	-	-	-	ON
400	-	-	-	ON	-	ON
500	-	ON	-	-	ON	ON
630	ON	ON	ON	ON	ON	ON

ON = ON position, - = OFF position

The processor of the monitor unit sets the measuring range and the short-circuit recording range according to the value set on the DIP switch; see Tab. 3. When the set value is less than 80 A included, the measuring range is 80 A. When the set value is less than 160 A incl., the measuring range is 160 A. When the set value is less than 320 A incl., the measuring range is 320 A and when the set value is more than 320 A incl., the measuring range is 630 A. The short-circuit recording range is 2000 A when the set value is less than 160 A incl. and the short-circuit recording range is 6000 A when a higher value is set. The processor of the monitor unit checks the DIP switch status periodically every second. When it detects that the status change remains for the next 30 seconds, it will restart the instrument.

Tab. 3: Setting of the measuring range and of the short-circuit recording range according to the rated fuse current:

I_{nom} fuse (A)	40	50	63	80	100	125	160	200	224	250	315	350	400	500	630	
Meas. range	80 A				160 A				320 A				640 A			
Rec. range	2000 A							6000 A								

The status of the DIP switch is scanned after the power supply of the MEg71 monitor unit is turned on or there is a voltage on the LV feeder and the measuring current range is set according to the status. At the same time, the range is saved in the memory and displayed on the display of MEg71D and on LEDs of MEg71S.

The preset value of the fuse can be checked at the display version MEg71D anytime in single-step operation by changing to the step 22 with identification **Hod**; see Tab. 1. The set value of the fuse at the slim version of the MEg71S monitor with LEDs is indicated for 1 minute by the lighting second and third triple of yellow LEDs, which copy the status of poles of the DIP switch according to Tab. 2. This is indicated by the LEDs only when the power supply or the LV feeder voltage is restored.

If all poles of the DIP switch are in the **OFF** position, the **ERROR** message will appear on the display of the MEg71D output feeder monitor and the MEg71S output feeder monitor indicates the fault condition using a LED running through all current LEDs from the left to the right.

The short-circuit currents are recorded up to more than the tenfold measuring range.

6/ DESIGN

MEgML71 Measuring rail

The basis of the MEgML71 measuring rail in Fig. 1 is a glass-reinforced epoxy laminate panel, on which there are three sensors labelled L1, L2 and L3 mounted for measuring the phase currents I_{L1} , I_{L2} and I_{L3} and the phase voltages U_{S1} , U_{S1} and U_{S3} of the busbars. Each sensor contains a ring-type current transformer with secondary circuit disconnection overvoltage protection and front-end resistors for measuring voltages ensuring the overvoltage category CATIV/300 V. The measuring rail is to be put on the LV busbars with the sensor side; the fuse or disconnector side is to be applied to the side with printed circuits. The correct position of the measuring rail is indicated by legends on the sensors.

The identification information about the MEgML71 measuring rail are given on the rating plate located between the sensor **L1** and **L2**. Fig. 2 shows an example of the rating

plate. There is an eight-pin **X3** connector at the upper end of the measuring rail, see Fig. 3, to which contacts of the switches are connected indicating that the fibre of the individual fuses is broken, and a contact indicating that the rod of the disconnector rail is handled. There is also a folded flat cable terminated by a CANNON connector at the upper end of the measuring rail that can be connected to the output feeder monitor unit. Fig. 4 shows a detail of the CANNON connector with the slide six-pole DIP switch for setting the measuring range according to the rated value of the installed fuses. There is a housing with arms screwed to the termination of the CANNON connector, which protects the CANNON connector from falling through the hole in the panel of the LV cabinet into the area with live parts; see Fig. 5.

Fig. 6 shows the **X6** connector located in a plastic housing and connected to the lower end of the measuring rail through a four-core voltage-rated round cable. The **X6** connector has a removable part with two quads of spring contacts for serial chaining of the individual measuring rails in the LV cabinet. When the voltage on the LV feeder is measured, a three phase front-end resistor is to be connected at the lower end of the measuring rail to the terminals **X4** and **X5** and fixed mechanically to the measuring rail using a binding tape. The three-phase front-end resistor has flexible frost-resistant red voltage cords with eyes screwed into modified lugs of the V-clamps. The L1 phase voltage of the LV feeder is to be connected to the U_{v1} input of the three-phase front-end resistor, the L2 phase voltage to the U_{v2} input and the L3 phase voltage to the U_{v3} input. Fig. 7 shows a rating plate of the three-phase front-end resistor.

A coupling with a mounting and a screw M12 with washers are used for power interconnecting the LV busbar and the contact of the fuse or disconnector rail; see Fig. 8a and Fig. 8b. The assembly in Fig. 8a applies to LV busbars provided with a threaded insert, whereas the assembly in Fig. 8b with a longer screw M12 and a nut is used for installing the measuring rail to busbars without an in-built threaded insert. Fig. 14a and Fig. 14b show the layout of components.

Output feeder monitor unit

Fig. 9 shows mounting dimensions of the output feeder monitor in the slim version MEg71S. Fig. 10 shows mounting dimensions of the output feeder monitor in the display version MEg71D. Both of the versions are based on a unit body with the width 93 mm, height 15.8 mm and depth 107 mm with guides and side locking details. The guides are to be inserted into the guide rails during installation of the output feeder monitor. There is a 25-pin double-row CANNON connector on the rear side of the unit for connecting to the MEgML71 measuring rail. Fig. 11 shows an example of rating labels of both versions of the output feeder monitors.

The versions MEg71S a MEg71D of the output feeder monitors differ in their front panels. The slim version MEg71S has the indicating LED **U**, three quads of LEDs labelled **I1**, **I2** and **I3** and the LED **RUN**. The indication of the individual LEDs is described in the previous chapter. The panel of the version MEg71D of the output feeder monitor uses an eight-digit alphanumeric LCD with controlled backlighting for displaying measured values, an indicating LED **RUN** and an environment-resistant foil **SET** button with mechanical response.

An optional part of the structure of the MEg71 output feeder monitor set is a set of plastic guide rails (Fig. 12) designed for additional installation of the MEg71 output feeder monitor in operating LV cabinets with fuse and disconnector rails. The set of guide rails is to be inserted into a narrow longitudinal cut of 18 mm height made in the panel of the LV cabinet above the fuse or disconnector rails. The cut width and the number of intermediate guide rails is determined by the number of installed measuring rails of the standard width 100 mm. The connecting element of the set of guide rails is a covering angle piece, to which plastic guide rails with locks are screwed (L.H., intermediate and R.H.). The set of guide rails is identical for both versions of the output feeder monitor units. It is attached to the panel of the LV cabinet using self-drilling screws M4 located above the guide rails.

7/ POWER SUPPLY, COMMUNICATION AND PROGRAMS

When voltage dips and interruptions shall be measured and recorded, it is necessary to use an uninterruptible 12 V_{DC} power supply for supplying the MEg71 output feeder monitor set and the communication unit. The MEg101.4 uninterruptible power supply (overvoltage category CATIV/300 V) with an external accumulator and 30 W power can be used or the MEg101.5 uninterruptible power supply (overvoltage category CATIV/300 V) with supercapacitors and 10 W power. The MEg101.5 power supply can be used for supplying up to 14 pcs of MEg71S or 10 pcs of MEg71D without a communication unit. The

MEg101.4 power supply can be used for supplying more than 25 pcs of MEg71S or 15 pcs of MEg71D with a communication unit. The MEg202.3 communication unit can be used for remote communication of GSM 3G networks with GPRS service. For more detailed description of the power supplies and the communication unit see www.e-mega.cz.

Fig. 13 shows a wiring example of measuring rails, an uninterruptible power supply and a communication unit. The above mentioned uninterruptible power supplies and the communication unit are to be installed on a DIN rail horizontally or vertically. They can be installed also separately. Fig. 15 shows their sizes. When installed side by side, they can be interconnected advantageously by means of a H-BUS busbar. The MEg202.3 communication unit has a processor performing basic RTU functions (input and output signals) with a possibility of compression and encryption of the transferred data.

The communication interface of the MEg71 output feeder monitor is RS485 with **a**, **b** signal wires. Basic measured variables and other values are displayed or indicated on the display or the indicating LEDs of the MEg71 output feeder monitor unit; other values are also available via the RS485 interface with MODBUS protocol or a more efficient proprietary protocol. The output feeder monitor set can be connected to both local and remote measuring systems via the RS485 interface.

The output feeder monitor set also includes a CD with **Merci** and **Data Viewer** SW applications. The **Merci** application is used for parametrizing the measurements, including recording and reading the user information about the LV feeder. Besides, it is used for on-line measuring the voltages and currents, visualising the status of fuses of the LV feeder and reading the measured data. The measured data are saved in the .MDAT format for further processing. The MEg71 output feeder monitor has the data of periodic measurements separated from the data of events. Events can be selected from the data of events and displayed using the **Merci** application; see Fig. 16.

The **Data Viewer** application evaluates and displays data of one or more consecutive data files in .MDAT format from the same measuring instrument. The measured data can be exported to a text file using the **Data Viewer** application. For user specifications of the mentioned applications see the CD and for their updates see www.e-mega.cz.

The **WebDatOr** database application works with multiple data files in the .MDAT format from various types of devices.

8/ INSTALLATION

Safety information. Maximum attention must be paid to this information.



Warnings draw attention to the facts presenting safety risks to the operator.



Cautions denote conditions and circumstances that can damage the MEG71 output feeder monitor set.

Explanation of symbols used in the user manual and in the specifications of the MEG71 output feeder monitor:



Warning, risk of electric shock



Note in documentation / Warning, risk of danger

CAT IV

Overvoltage category characterising the status of the transient overvoltage and the measurement category defining the section of the LV network. CATIV is applicable to the low-voltage distribution network from the transformer station to the fuses in the electrometer.



Safety class II, double or increased insulation



Ground, grounding terminal

IP code

Degree of protection provided by enclosure



The product is intended for recycling and for collection points



Declaration of Conformity – European Community



Warning

- **Be careful, the operator performing the installation must be equipped with personal protective equipment and additional safety devices and use them during the installation.**
- **When the MEG71 output feeder monitor set is used in a different way than it is specified by the manufacturer, the protection provided by MEG71 output feeder monitor set can be impaired.**
- **The MEG71 output feeder monitor is a Class A product designed for industrial environments. It may cause radio interference in other environments.**

- The operator installing and removing the MEg71 output feeder monitor set must be qualified for live-line working and working near dangerous voltages. The operator must be trained in providing the first aid.
- The MEg71 output feeder monitor set may be operated only by qualified persons provided with personal protective equipment against electric shock.
- It is not permitted to connect the MEg71 output feeder monitor set to phase voltages higher than $300 V_{AC}$ in LV networks between MV/LV transformers and electrometers of customers characterized by the overvoltage category CAT IV/300 V, otherwise there is a risk of electric shock.
- Maintenance and repairs of the MEg71 output feeder monitor set may be carried out only by the manufacturer or service organizations authorized by the manufacturer.
- The basic components of the MEg71 output feeder monitor set can be used only according to the list given in Chap. 9.
- The power supply and possibly also the communication unit must comply with requirements of the overvoltage category in the place of installation.



Caution

- The installation of the MEg71 output feeder monitor set is always carried out in a **de-energised state**. The MEg71 output feeder monitor set can be installed into new cabinets during their production or alternatively into already operating cabinets. The MEgML71 measuring rail of the MEg71 output feeder monitor is to be installed between the LV busbar and the fuse or disconnector rail; the MEg71 monitor unit is to be placed in the area above the fuse and disconnector rail.
- The MEg71 output feeder monitor set can be also installed additionally into an already operating LV cabinet provided with the fuse or disconnector rails if safe distances of live parts of the given LV rails from conductive components of the constructional parts of the LV cabinets are observed. The position of the fuse or disconnector rail after the installation of the MEgML71 measuring rail is raised by 26 mm
- Compliance of the rated current on the rating plate of the MEgML71 measuring rail is to be checked towards the rated value of the current of the fuse or disconnector rail.
- The set of guide rails according to Fig. 12 is to be used for installing the MEg71S or MEg71 measuring unit into operating LV cabinets, or a safe equivalent design in new LV cabinets.
- When the feeder voltage is measured, a three-phase front end resistor is to be connected to the MEgML71 measuring rail with three modified lugs of the V-clamps.

1. Before the MEgML71 is installed into an already operating LV cabinet, it is necessary to disconnect the V-clamps of the fuse or disconnecter rail from wires of the LV feeder, take out the fuses and remove the installed fuse or disconnecter rails from the busbars of the cabinet.
2. A longitudinal 18 mm cut for placing the output feeder monitor units is to be cut out into the panel of the LV cabinet above the fuse or disconnecter rails of the LV feeders, which will be fitted with the MEg71 output feeder monitor set.
3. Plastic guide rails are to be used according to Fig. 12; the rail is to be inserted into the cut out hole and points on the panel of the LV cabinet are to be marked to drill holes for self-drilling screws attaching the set to the panel.
4. If there are indicating contacts for fuse interruptions and possibly a contact for rod handling on the disconnecter rail, than a counterpart of an eight-pole connector **X3** of the MEgML71 measuring rail is to be connected to the contact wires according to Fig. 3.
5. When the fuse or disconnecter rail is not provided with indicating contacts, the output contacts U_{V1} , common wire, U_{V2} , U_{V3} of the three-phase front-end resistor are to be screwed into the double terminals **X4** and **X5** of the MEgML71 measuring rail and the three-phase front-end resistor is to be attached mechanically to the measuring rail using a tightening tape with the dimensions of 300 × 3.6 mm in accordance with Fig. 6. The modified lugs of the V-clamps are to be screwed on wires of its voltage inputs **UV1**, **UV2** and **UV3**; see Fig. 6.
6. The individual mounting elements of the measuring and fuse or disconnecter switch rail are to be prepared according to the version of the LV busbars (without/with a threaded insert) and they are to be installed. The order of the LV busbars (top-down) is assumed to be L1, L2 and L3 for the measurement.
 - a) busbar without a threaded insert; see Fig. 8a and Fig. 14a:
 - the screw M12×65 is to be screwed into the busbar from behind
 - the MEgML71 measuring rail is to be put **with the sensor side** on the screws of all three busbars vertically in the order L1, L2 and L3
 - the contact spring is to be put on the coupling with a mounting and the coupling is to be put on the screw M12 and inserted into the hole of the measuring rail sensor; it is done gradually in the phase L1, L2 and L3
 - contacts of the basic part of the disconnecter or fuse rail are to be put on the screws M12 with the measuring rail and couplings with mountings
 - the flat and spring washer is to be gradually put on the individual screws M12 behind the fuse rail and the unit is to be tightened with the required mechanical moment.

- b) busbar with a threaded insert; see Fig. 8b and Fig. 14b:
- first the spring washer and then the flat washer is to be inserted under heads of all three screws M12×40
 - the screws M12 with washers are to be inserted from the front into holes of the contacts of the basic part of the disconnector or fuse rail where they are to be locked against falling out
 - the couplings with mountings with installed contact springs are to be inserted into the measuring rail **from the printed circuit side**
 - the measuring rail with the couplings is to be put on the screws M12 protruding from the completed fuse or disconnector rail; the L1 phase sensor is up
 - the set of the fuse or disconnector rail and the measuring rail with the sensors is to be screwed using the screws M12 to the busbars with threaded inserts. The screws attaching the busbar, measuring rail and the fuse or disconnector rail are to be tightened with the required mechanical moment.
7. Plastic parts are to be attached to the basic part of the installed disconnector rail.
8. The modified lugs with flexible wires from the three-phase front-end resistor are to be put on the individual wires of the cable of the LV feeder according to the marked phases. The wires of the LV cable are to be put into the V-clamps of the fuse or disconnector rail and the V-clamps are to be connected using the modified lugs
9. The CANNON connectors of all installed measuring rails are to be pulled in front of it through the longitudinal cut in the panel of the LV cabinet. The arms of the housings prevent the connectors from falling behind the panel.



If it is not possible to prevent a CANNON connector from falling into areas with live parts in place of installation in the recommended way, it is necessary to use another safe method.

10. The set of plastic guide rails with locks is to be inserted into the longitudinal cut and is to be screwed on by means of self-drilling screws.
11. Knife fuses of the defined rated current are to be inserted into the individual fuse or disconnector rails.
12. Identical values are to be set on the corresponding CANNON connectors on the slide DIP switches according to the rated current of the fuses of the individual fuse or disconnector rails. Tab. 2 the setting of the individual current values on the DIP switch is given in Chap. 5.
13. The housing with arms is to be unscrewed from the CANNON connector and the connector is to be put on the CANNON counterpart located on the rear side of

the output feeder monitor unit. Both parts of the CANNON connector are to be screwed together.

14. The output feeder monitor unit is to be inserted into the guide rails with locks.
15. The housing with both parts of the **X6** connector is to be bound using two binding tapes DV-200AFR, 3.6 to the insulated part of the middle power wire of the cable of the LV cabinet according to Fig. 17. Both the surface and air distance of all parts of the **X6** connector must be more than 11 mm distant from live parts.
16. After all the housings with the **X6** connectors are installed on insulated parts of the phase wires, four-core interconnecting cables of the busbar are to be prepared according to their distance. The individual cores are to be terminated with tubes and inserted into the taken out removable parts of the **X6** connectors. The cables must comply with safety requirements for installations into LV cabinets.
17. The removable parts of the **X6** connectors are to be inserted into the parts of the **X6** connectors located in plastic housings and the busbar cables are to be bound with binding tapes to the extreme phase wires of the cable of the LV feeder according to Fig. 17.
18. The power supply and possibly the communication unit are to be connected to the cables of the busbar of the interconnected MEg71 output feeder monitor set according to Fig. 13. If the length of the interconnecting cable is longer than 1 m, then it is necessary to use a shielded four-core cable and its shielding is to be grounded on the side of the communication unit.
19. The circuits of the 12 V power supply is to be connected to the supply line voltage and the specified safety requirements are to be met.
20. After all parts of the installation of the MEg71 output feeder monitor set are checked in the specified procedure for the place of installation, the line voltage is to be connected.
21. After the power supply is turned on, the indicating LEDs **RUN** are to be checked for permanent lighting. Then the displaying or indicating elements are to be checked according to Chap. 5.
22. The local communication with the RS485 serial interface is to be verified with the Merci application using a computer with RS485 interface or through a RS485/USB converter. The features and operation of the Merci application are specified on CD included in the accessories of the MEg71 output feeder monitor set.

23. When a remote communication is used, functions of the remote communication are to be set and enabled in the way specified in the user instructions for the communication unit.

Changing the current measurement range when changing the fuse rating



Warning! When the CANNON connector is handled without a housing with arms, the connector can fall into the area behind the panel of the LV cabinet with dangerous live parts.



When the fuse values are changed, it is necessary to change also the measuring range of operating and fault currents, and therefore it is necessary to change the value set on the DIP switch in the termination of the CANNON connector. The change is written into the monitor unit automatically.

1. The output feeder monitor unit, to the rear side of which the CANNON connector is screwed, is to be slid forward from the guide rails.
2. The rated value of the newly installed fuses of the corresponding LV rail is to be set on the six-pole DIP switch located in the housing of the CANNON connector according to Tab.2, Chap. 5.
3. The output feeder monitor unit with the screwed CANNON connector is to be inserted back into the guide rails with locks.

9/ LIST OF COMPONENTS OF THE OUTPUT FEEDER MONITOR SET MEG71

Basic

- 1 pc of output feeder monitor unit in MEG71/D or MEG71/S design
- 1 pc of MEGML71 measuring rail with a CANNON connector and a housing with arms
- 3 pcs of couplings with mounting
- 3 pcs of contact springs to be placed under the couplings
- 3 pcs of hex. head screws M12×40
- 3 pcs of hex. head screws M12×65
- 3 pcs of nuts M12
- 3 pcs of flat washers to be placed under heads of screws M12
- 3 pcs of spring washers to be placed under heads of screws M12
- 4 pcs of CV-200 AFR, 3.6 black binding tape
- 1 pc of CD with the user manual and Merci application and Data Viewer application

Optional

- 3-phase front-end resistor
- tightening tape GT-300 ICB (292 × 3.6 mm)
- set of guide rails with locks
- guide rail, R.H.
- guide rail, intermediate
- guide rail, L.H.
- MEG202.3 GPRS communication unit
- interconnecting HBUS busbar
- USB/RS485 protocol converter
- MEG101.4 uninterruptible power supply
- MEG101.5 uninterruptible power supply

10/ ORDERING DATA

- A pcs of MEg71S output feeder monitor sets
- B pcs of MEg71D output feeder monitor sets
- (A+B) pcs of MEgML71 measuring rails ($I_{nom} = 250\text{ A} / 400\text{ A} / 630\text{ A}$)
- N pcs of three-phase front-end resistors
- C sets of guide rails with locks (number of positions in individual sets)
- C pcs of R.H. guide rails
- (A+B+C) pcs of intermediate guide rails
- C pcs of L.H. guide rails
- N pcs of MEg202.3 GPRS communication units
- N pcs of USB/RS485 protocol converters
- N pcs of MEg101.4 uninterruptible power supplies
- N pcs of MEg101.5 uninterruptible power supplies
- N pcs of interconnecting HBUS busbars

11/ MANUFACTURER

MEgA – Měřící Energetické Aparáty, a.s.

664 31 Česká 390, Czech Republic

Tel. +420 545 214 988

e-mail: mega@e-mega.cz

web: www.e-mega.cz



Output Feeder Monitor Set MEG71 User manual

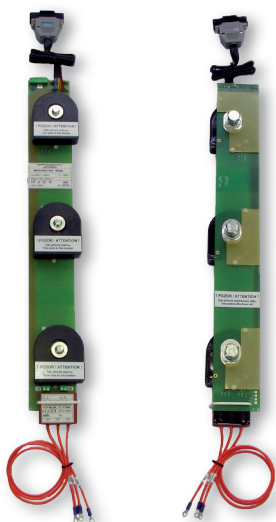

MEGA – Měřicí Energetické Aparáty, a.s.
664 31 Česká 390
Czech Republic
www.e-mega.cz