

## Determining the **efficiency** of a **motor**

**DC rotating machines are frequently encountered in industry, factories and manufacturing and repair workshops, in particular.**

The purpose of the application described here is to assess two DC machines. On the basis of the specifications provided by the manufacturers of the 2 machines, it is possible to determine an overall theoretical efficiency for them and thus obtain a value of reference. The results of the measurements below will enable us to check the peak efficiency of this system.

The tests were carried out on two linked DC machines: a machine wired as a motor which drives the shaft of another machine, wired as a generator.

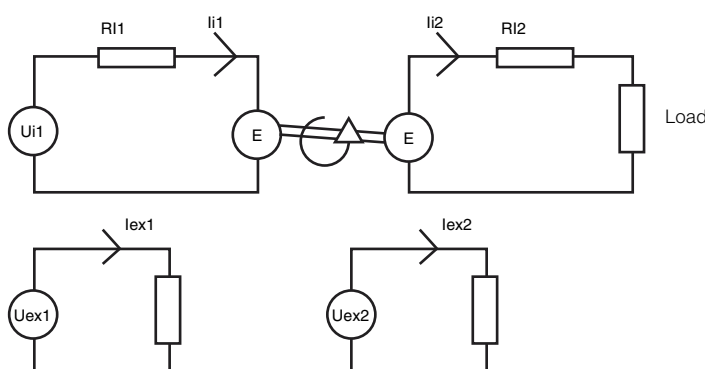

Wiring diagram

**Electromechanics**

**Maintenance**

**Power**

# Checking the efficiency of a motor

## DC motors

DC motors comprise two distinct parts: the armature (rotor) and the inductor (stator). As a reminder, the stator is the stationary part of the electric motor. It can create a magnetic field which produces the electromechanical torque through interaction with the rotor's magnetic field, thus driving the motor.

Theoretically, the specifications are as follows:

Motor	N = 1,500 rpm		P = 3 kW	
	Inductor	Armature		
U	200 V	220 V		
I	0.7 A	15 A		

Generator	N = 1,500 rpm		P = 3 kW	
	Inductor	Armature		
U	200 V	220 V		
I	0.8 A	14 A		

## Practical case...

### First step:

#### Determining the armature resistance of each motor

It is advisable to run the motor before measuring. Heat influences the resistance of the armature. To obtain reliable measurements, they must be performed at the motor's normal operating temperature.

After checking that no voltage is present on the armature terminals using a C.A 760N VAT, simply activate the "Ohmmeter" mode of the "Multimeter" key on the HandScope®. The values measured are then 1.5  $\Omega$  for the motor and 1.37  $\Omega$  for the armature of the generator.

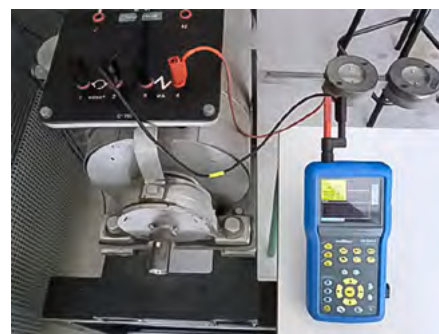

Using the HandScope® oscilloscope to measure the resistance

### Second step:

#### Adjusting the two voltages on the terminals of the inductor

If the inductor voltage tends towards zero and a voltage is present in the armature, the speed will tend towards infinity, from a theoretical point of view. In practice, this phenomenon could damage the motor.



Here, channel 1 of the HandScope® is connected to the inductor via the BNC/Banana adapter.

The HandScope® oscilloscope is hooked up to the two channels of the inductor; you can perform measurements simultaneously because the chassis earths are not connected. The channels are totally isolated up to 600 V CAT III from one another and in relation to the earth. In this way, they can be used to obtain signal measurements with different electrical references in total safety.

First, the HandScope® must be set to "DC voltage". An initial automatic reset can be performed by pressing the "AutoSet" button. If necessary, it is also possible to make manual adjustments.

By connecting the MA100 clamp to the HandScope®, it is possible to monitor the voltage and current simultaneously. The measurements indicate a current of 0.5 A for the motor and 0.8 A for the generator.

# Checking the efficiency of a motor

## Third step:

### Measuring the input and output voltages and currents

Simply increase the armature voltage gradually while monitoring the motor speed, so that it does not exceed the rated speed.

The SCOPIX® oscilloscope is connected so as to monitor the voltage and current of the armature on both machines. Because the chassis earths are isolated, short-circuits cannot occur.

The SCOPIX® in Multimeter mode allows channel-by-channel adjustment until the required traces are obtained.

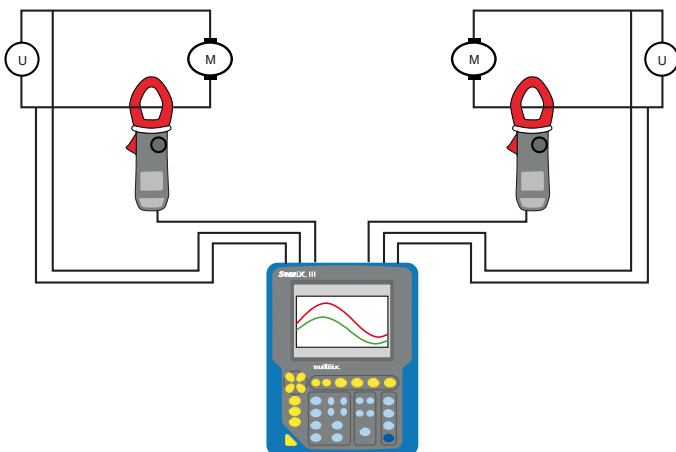

This mode allows you select each channel individually; the definition of unit A will be filled in either automatically, if you are using a PROBIX® HX0034 clamp, or manually if you are using the other clamps, according to their transformation ratio to allow simple direct readings.

Then gradually increase the motor speed while monitoring it with the C.A 1725 tachometer. During this experiment, the speed reached 1,460 RPM on the motor shaft with an armature voltage of 183 V and a current of 4.91 A.

The measurements made on the output of the DC machine wired as a generator show a voltage of 216 V and a current of 2.79 A. We now have all the data needed to calculate the torque and the power.

#### Electrical context of the motor

- Armature:  $U_{i1} = 183 \text{ V}$  and  $I_{i1} = 4.91 \text{ A}$
- Inductor:  $U_{ex1} = 100 \text{ V}$  and  $I_{ex1} = 0.5 \text{ A}$
- $n = 1,460 \text{ rpm}$
- $R_{i1} = 1.5 \Omega$

#### Electrical context of the generator

- Armature:  $U_{i2} = 216 \text{ V}$  and  $I_{i2} = 2.79 \text{ A}$
- Inductor  $U_{ex2} = 100 \text{ V}$  and  $I_{ex2} = 0.8 \text{ A}$
- $n = 1,460 \text{ rpm}$
- $R_{i2} = 1.37 \Omega$

## Conclusion:

The efficiency corresponds to the output power divided by the power absorbed by the system. Indeed, losses occur in the resistance, in the pole piece of the armature (losses due to the magnetic field which causes the system to rotate) and there are also mechanical losses due to friction.

All these losses lead to reduced efficiency.

Without going into the details of the mathematical calculations, using the general formula Efficiency = (Output power/Active power), the result obtained corresponds to an efficiency of  $R = 0.5859$ .

The efficiency is expressed as a value between 0 and 1. the closer the value is to 1, the better the efficiency is. Here, the efficiency is 0.5859, which can also be expressed as a percentage, giving us 59 %. This value clearly indicates the low efficiency of the system in question.

# Checking the efficiency of a motor

## Measuring instruments used

- SCOPIX III OX 7104 and/or HANDSCOPE OX 5042 oscilloscopes
- PROBIX HX0031: PROBIX adapter for BNC cable
- PROBIX HX0033: PROBIX adapter for banana leads
- PROBIX HX0034: AC/DC current clamp, 0.02 A to 60 A<sub>RMS</sub> / 1 MHz
- MA100 current clamp
- CM605 current clamp
- C.A 1725 tachometer
- C.A 760N Voltage Absence Tester



The SCOPIX® III OX 7104 is an oscilloscope equipped with 4 isolated channels and bandwidth of 100 MHz.

With its 2 isolated channels, the HandScope® offers a bandwidth of 40 MHz.

The PROBIX® system, patented by Chauvin Arnoux/Metrix®, allows immediate recognition of the sensors connected to the isolated channels of the SCOPIX®. Furthermore, the PROBIX® probes power the sensors connected so there is no need for an additional power supply.

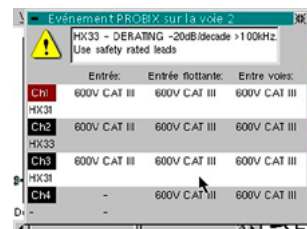

For practical exercises in an educational context, further information is available on the **minisite FAQ page of the SCOPIX minisite at [www.chauvin-arnoux.com/scopix](http://www.chauvin-arnoux.com/scopix)**.

Our Support Department is at your disposal to answer any questions on the products or their applications  
**[support@chauvin-arnoux.com](mailto:support@chauvin-arnoux.com)**.

**FRANCE**  
**Chauvin Arnoux**  
190, rue Championnet  
75876 PARIS Cedex 18  
Tel: +33 1 44 85 44 38  
Fax: +33 1 46 27 95 59  
export@chauvin-arnoux.fr  
www.chauvin-arnoux.fr

**UNITED KINGDOM**  
**Chauvin Arnoux Ltd**  
Unit 1 Nelson Ct, Flagship Sq, Shaw Cross Business Pk  
Dewsbury, West Yorkshire - WF12 7TH  
Tel: +44 1924 460 494  
Tel: +44 1924 455 328  
info@chauvin-arnoux.co.uk  
www.chauvin-arnoux.com

**MIDDLE EAST**  
**Chauvin Arnoux Middle East**  
P.O. BOX 60-154  
1241 2020 JAL EL DIB - LEBANON  
Tel: +961 1 890 425  
Fax: +961 1 890 424  
camie@chauvin-arnoux.com  
www.chauvin-arnoux.com

 **CHAUVIN  
ARNOUX**  
GROUP